

ISS.	AMEND	DATE
1	ISSUED	26/10/12
2	WHITE ADDED	23/03/17
3	RETOOL+DEL WHITE	03/05/22

PART No.	COLOUR	PIN Ø
FC681477	BLACK	Ø2.50
FC681478	BLACK	Ø2.10

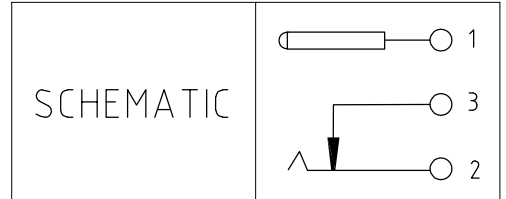
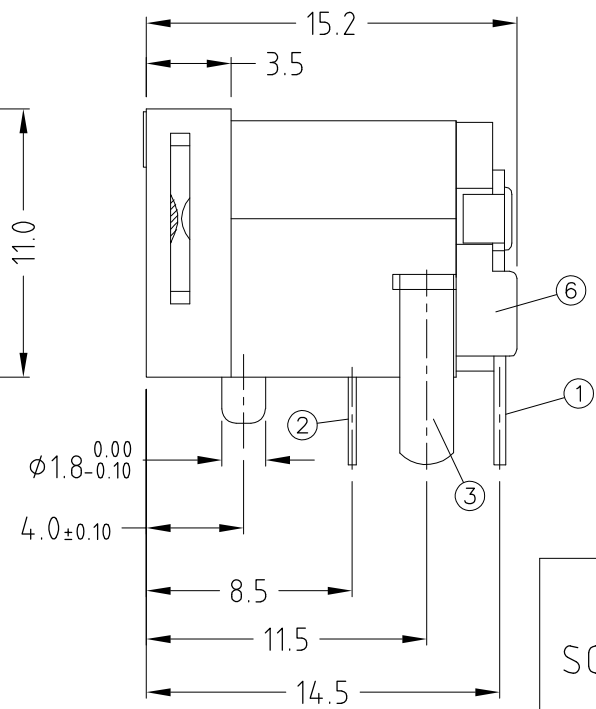
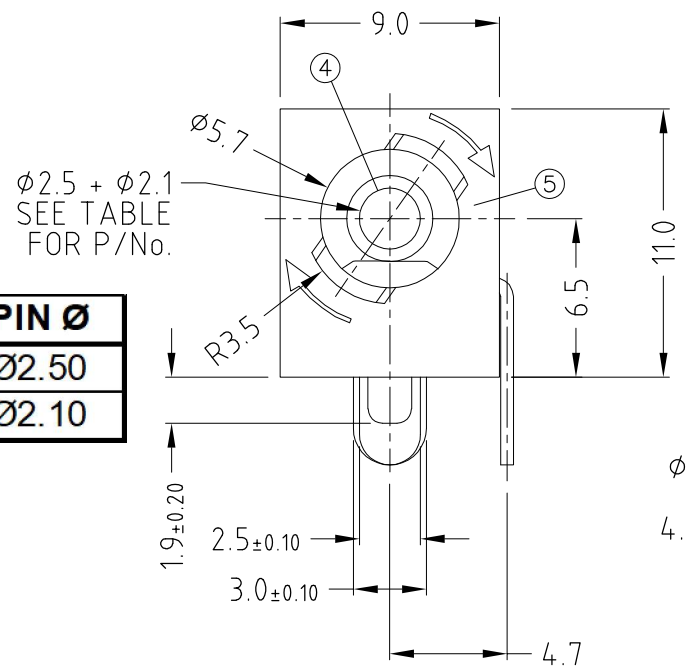

### SPECIFICATIONS

Contact Resistance : 30mΩ max  
 Current Rating : max 2.0A, 16V DC  
 Insulation Resistance : 100MΩ min at DC 500V  
 Dielectric Withstanding Voltage : AC 500V for 1 minute

UNLESS OTHERWISE SPECIFIED, TOLERANCE ON DECIMAL: ±0.3

1	TERMINAL	1	C2680 t=0.5	Sn PLATED
2	TIP TERMINAL	1	C5191 t=0.3	Sn PLATED
3	SHUNT TERMINAL	1	C2680 t=0.45	Sn PLATED
4	CENTRE PIN	1	BRASS BAR	Ni PLATED
5	HOUSING	1	PBT	UL-94V0 (BLACK)
6	COVER	1	PBT	UL-94V0 (BLACK)
No.	DESCRIPTION	QTY	MATERIAL	REMARK

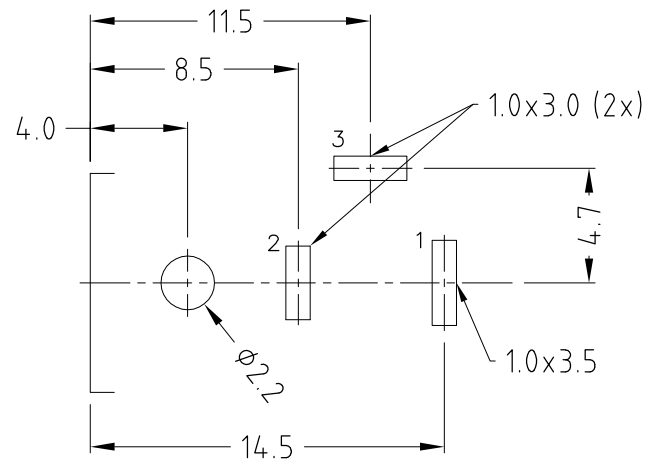

PCB LAYOUT BOTTOM VIEW

**RoHS**  
**COMPLIANT**

**TOLERANCE**  
 NO DEC. PLACE ±  
 1 DEC. PLACE ±  
 2 DEC. PLACE ±  
 HOLE Ø ±  
 ANGLES ±  
 UNLESS OTHERWISE STATED

**Cliff Electronic Components Ltd.**  
 76 Holmethorpe Avenue, Holmethorpe Industrial Estate,  
 Redhill, Surrey, RH1 2PF, England, UK  
 Tel: 01737-771375 Fax: 01737-766012 Website: www.cliffuk.co.uk

DIMENSIONS IN MILLIMETERS UNLESS OTHERWISE STATED. WORK TO DIMENSIONS. REMOVE ALL BURRS. IF IN DOUBT ASK.

3rd ANGLE PROJECTION:

DO NOT SCALE

MATERIAL: SEE TABLE

TITLE: LOCKING DC SOCKET Ø2.5mm + Ø2.1mm

FINISH: CLEAN - SEE TABLE (BLACK)

DRWG. No. **FC681477** FORM: A4DRWGH

DRAWN: T.J.O.

APPROVED: D.P.J.