

REVISIONS			
REV	DESCRIPTION	DATE	APPV
A	PRODUCTION RELEASE	JHAGER 5/27/22	DV 5/31/22

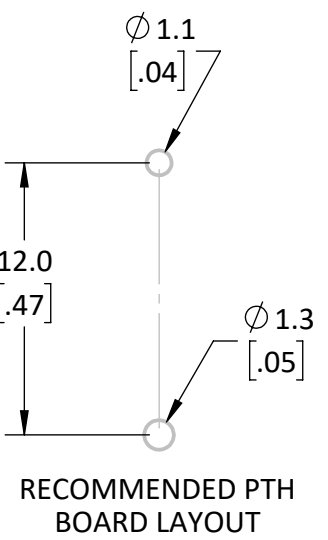
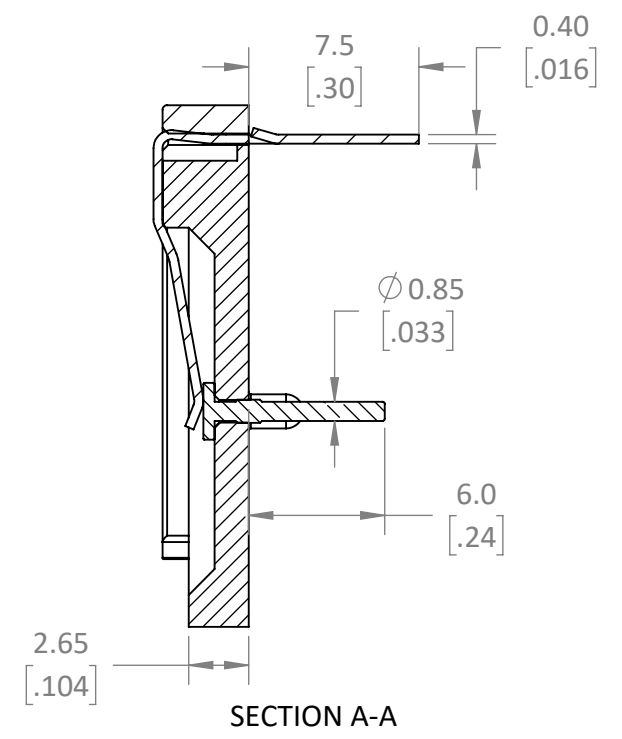
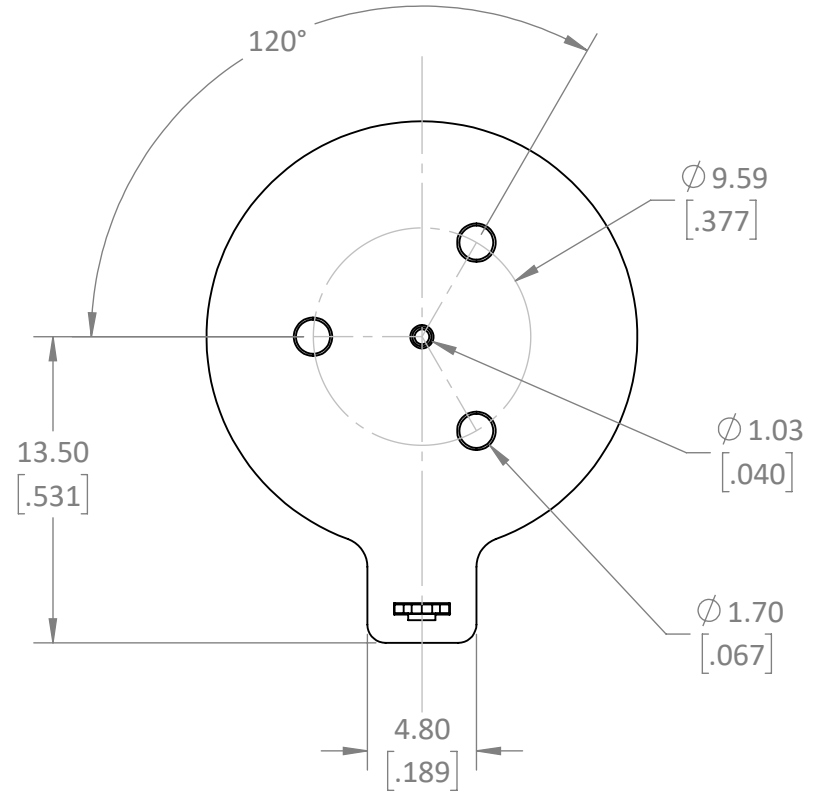
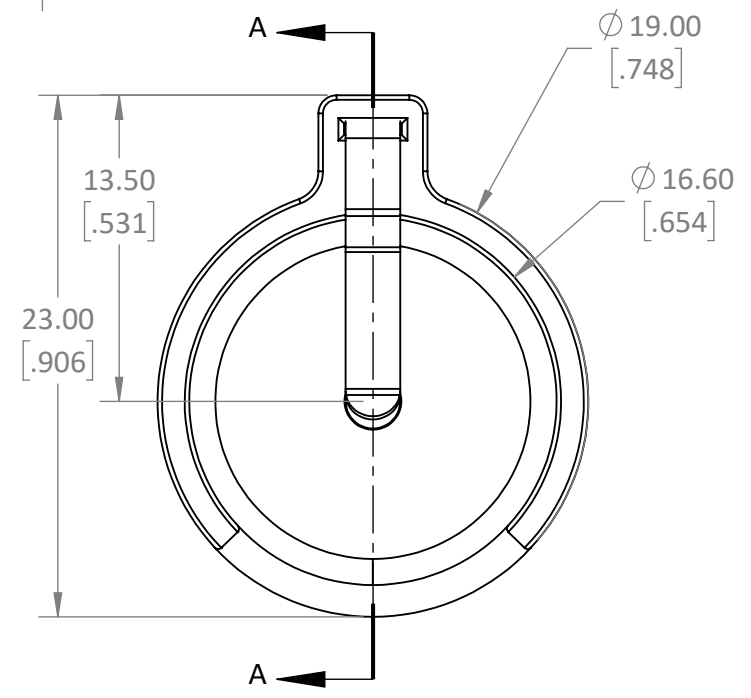
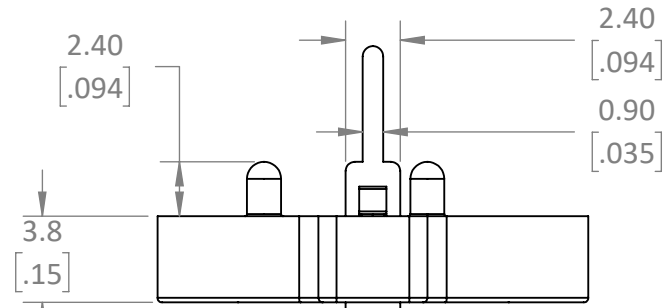

- NOTES: (UNLESS OTHERWISE SPECIFIED)
1. ALL DIMENSIONS ARE IN MILLIMETERS [IN].
 2. DIMENSIONS APPLY AFTER FINISHING.
 3. MANUFACTURE TO BE COMPLIANT WITH EU RoHS DIRECTIVE, USE MATERIALS THAT DO NOT CONTAIN REACH SUBSTANCES OF VERY HIGH CONCERN >1000ppm, AND USE DRC CONFLICT-FREE SOURCED MATERIALS.
 4. ELECTRICAL SPECIFICATIONS ARE FOR LISTED FOR REFERENCE ONLY. SEE LINX DATA SHEET FOR CURRENT PROPERTIES
 1. CONTACT RESISTANCE: NTE 50mΩ
 2. INSULATION RESISTANCE: 100MΩ MAX
 3. DIELECTRIC RESISTANCE: 500VAC
 5. MECHANICAL PROPERTIES
 1. MATERIAL: PBT BLACK
 2. OPERATING TEMPERATURE: -25° - +85°C
 3. UNLISTED DIMENSIONS CONTROLLED BY SOLID MODEL AT LATEST REVISION.

WARNING: THIS DRAWING CONTAINS PROPRIETARY INFORMATION THAT IS THE SOLE PROPERTY OF LINX TECHNOLOGIES, AND SHALL BE TREATED AS SUCH. NO DISCLOSURE OR REPRODUCTION OF THIS DOCUMENT IS PERMITTED, IN WHOLE OR IN PART, WITHOUT THE EXPRESS WRITTEN PERMISSION OF LINX TECHNOLOGIES OR ITS DESIGNATED AGENTS.

STE 159 ORT LANE
connectivity MERLIN, OR 97532

MATERIAL: PBT, STEEL BRASS	INTERPRET DIMENSIONS AND TOLERANCES PER ASME Y14.5.		PROJECTION:
WEIGHT:	.X ±2.0 .XX ±1.00 .XXX ±.500	ANGLES: ±1° SURFACE:	
FINISH: BLACK, NiSn GOLD	DRAWN: JHAGER ENGR: SHAWNH	DT: 5/27/22 DT: 5/27/22	

TITLE: BATTERY HOLDER THRU MOUNT PCB CR1620		
SIZE B	DWG. NO. C-BAT-HLD-011-THM	REV A
SCALE: 3:1	DO NOT SCALE DRAWING	SHEET 1 OF 1