

ISS.	AMEND	DATE
1	ISSUED WAS FCR	23/07/13

PART No.	COLOUR
CL681580	RED
CL681581	BLACK

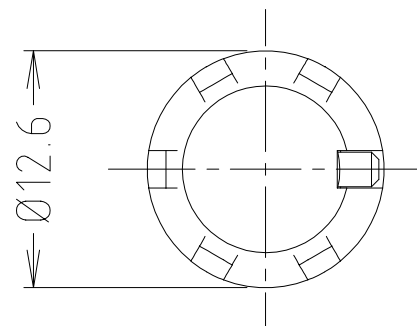

FOR COLOUR  
SEE TABLE

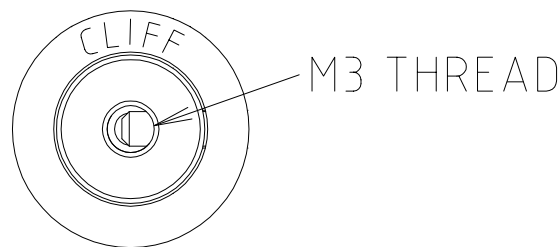
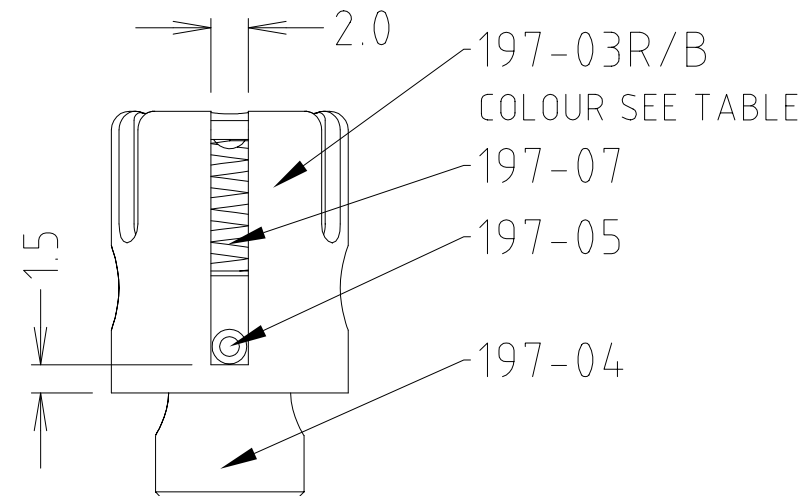
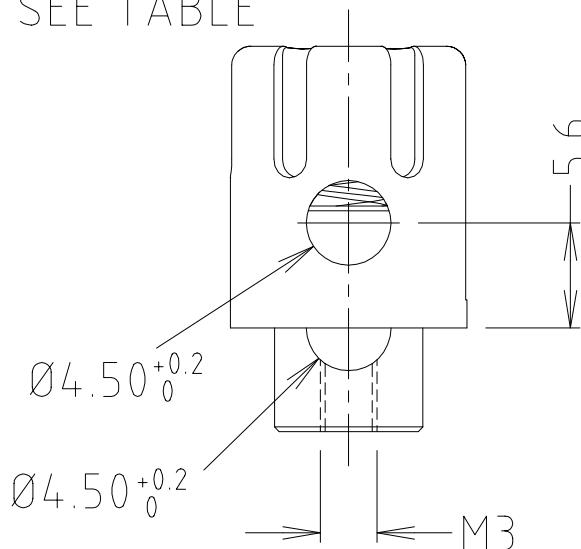
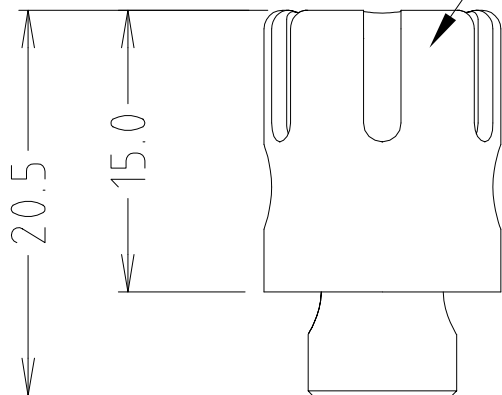

RATED: 48V 15A MAX

**RoHS**  
COMPLIANT

**TOLERANCE**  
NO DEC. PLACE ±  
1 DEC. PLACE ± 0.20  
2 DEC. PLACE ±  
HOLE Ø ±  
ANGLES ± 1/2°  
UNLESS  
OTHERWISE STATED

DO NOT SCALE

**Cliff Electronic Components Ltd.**

76 Holmethorpe Avenue, Holmethorpe Industrial Estate,  
Redhill, Surrey, RH1 2PF, England, UK  
Tel: 01737-771375 Fax: 01737-766012 Website: www.cliffuk.co.uk

DIMENSIONS IN MILLIMETERS UNLESS OTHERWISE STATED. WORK TO DIMENSIONS. REMOVE ALL BURRS. IF IN DOUBT ASK.

3rd ANGLE PROJECTION:

MATERIAL: ABS / BRASS

FINISH: SPARK FINISH 27VDI / NICKEL PLATED

DRAWN: T.J.O.

APPROVED: D.P.J.

TITLE: SPT1 SPRING TERMINAL ASSEMBLY

DRWG. No. **CL681580**

FORM: A4DRWGH

THE CONTENTS OF THIS DOCUMENT MUST NOT BE COPIED OR DISCLOSED  
TO A 3rd PARTY WITHOUT WRITTEN PERMISSION OF CLIFF UK. © 2013