

MHF® I

Supports up to 9 GHz, mated height of 3.0 mm max.

Product Specifications:

Mated Height (mm max.)	(1) 2.5 (2) 3.0		
Rece. SMT Size (mm)	3.1 x 3.0		
Applicable Frequency	DC ~ 9 GHz		
Characteristic Impedance	50 ohm		
VSWR (L=100 mm)	Connector	PLUG	RECEPTACLE
	DC~3 GHz	1.3 max.	1.3 max.
	3~6 GHz	1.5 max.	1.4 max.
	6~9 GHz	(1) 1.9 max. (2) 1.6 max.	1.8 max.

* Cable size O.D. (1) 1.80 mm, 1.32 mm, 1.13 mm, 0.81 mm, 1.37 mm (2) 2.0 mm

Applicable Cable Size:

20278-112R-**, 20670-001R-**
O.D. 1.80 mm / AWG 30
O.D. 1.32 mm, 1.13 mm / AWG 32
O.D. 0.81 mm / AWG 36
20351-112R-37
O.D. 1.37 mm / AWG 30
20767-001R-20
O.D. 2.0 mm / AWG 26

Applicable Standards (Reference Only):

5G sub-6, Wi-Fi 6E, LTE/LTE-Advanced, LPWA, Bluetooth, GPS



► Solderless micro-coax termination technology "i-Fit®" provides consistent performance

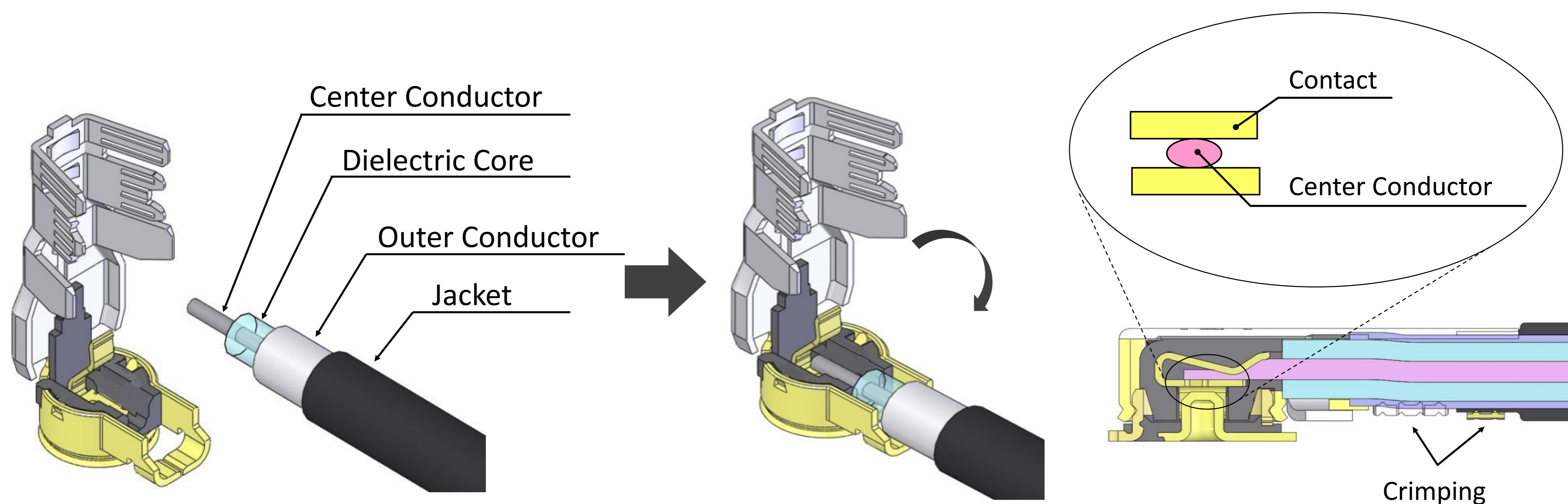

► Small form factor with big performance through 9 GHz

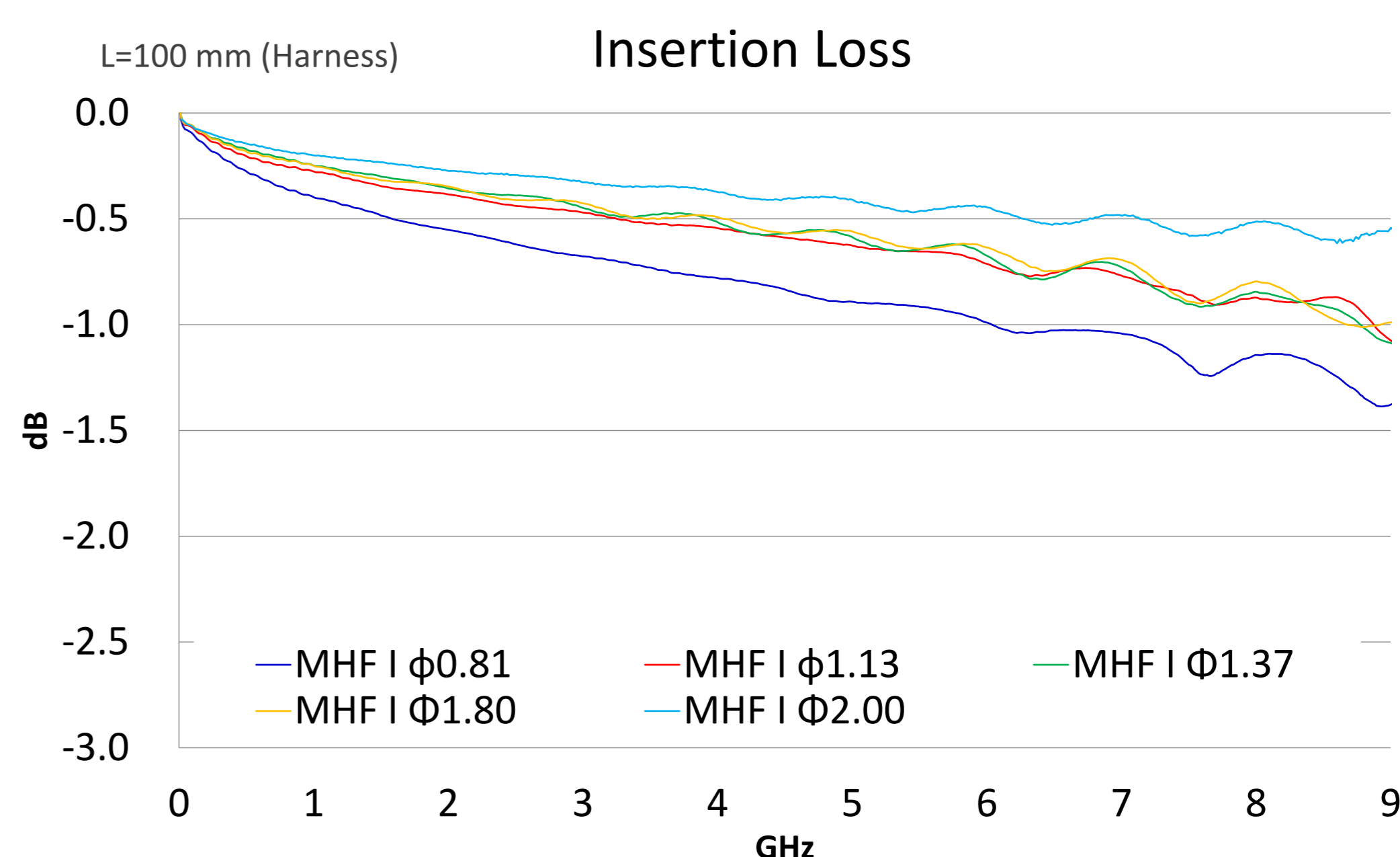
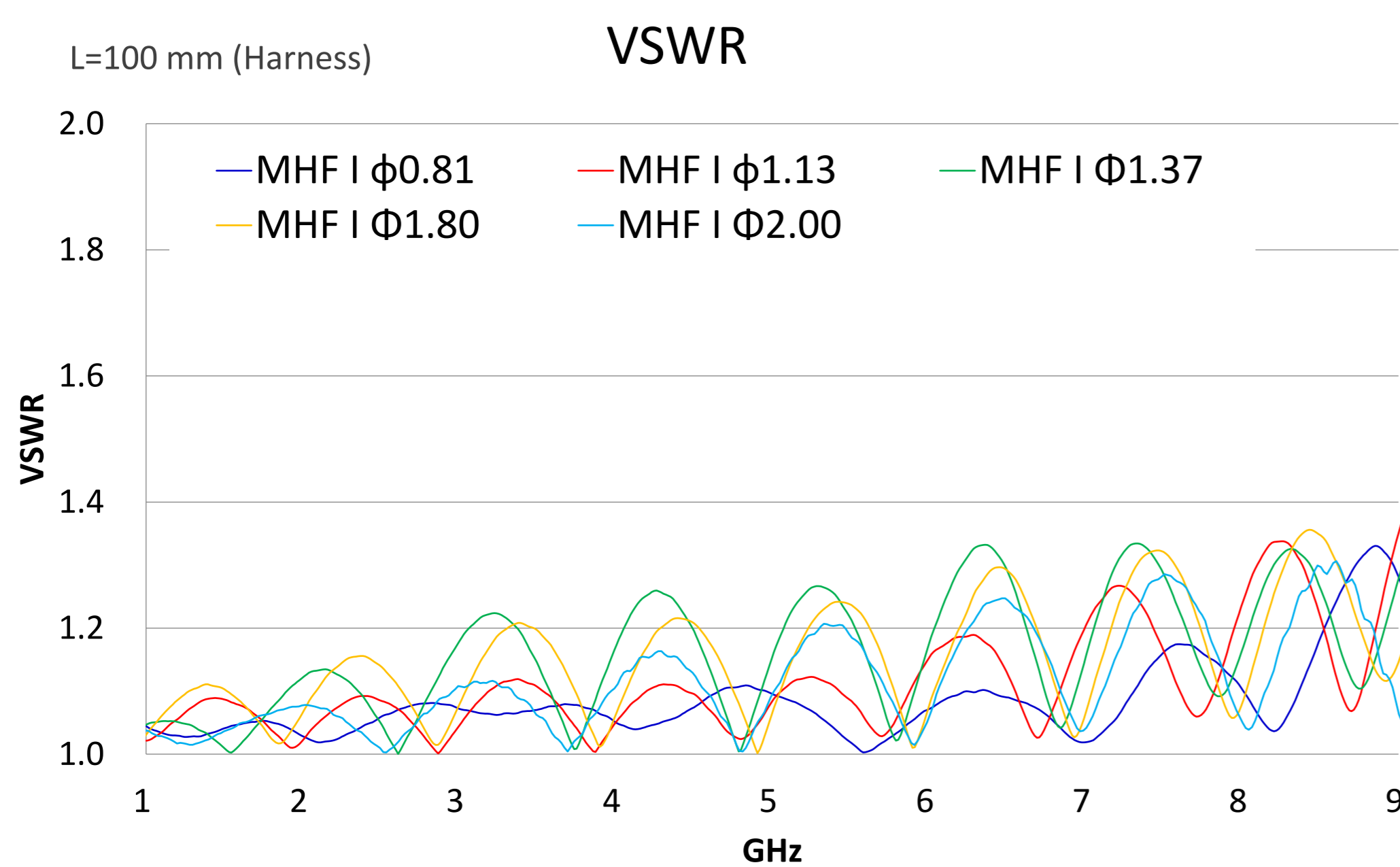

► MHF® I plug available with various cable O.D. and additional locking option

Product name		MHF® I LK	MHF® I	MHF® I
Lock		With Lock	Without Lock	Without Lock
Mating Height		2.9 mm max.	2.5 mm max.	3.0 mm max.
Coax O.D. (Center Conductor AWG)	2.00 mm (AWG#26)			●
	1.80 mm (AWG#30)	●	●	
	1.37 mm (AWG#30)	●	●	
	1.32 mm (AWG#32)	●	●	
	1.13 mm (AWG#32)	●	●	
	0.81 mm (AWG#36)	●	●	
Receptacle		MHF® I receptacle 20279-001E-** (3 pads) / 20441-001E-01 (4 pads)		

Component Parts Details

MHF[®] I plug Au (0.81,1.13,1.32,1.80)

Recommended P/N 20278-112R-**

PART No.	APPLICABLE CABLE
20278-112R-08	AWG#36 (0.81 O.D.)
20278-112R-13	AWG#32 (1.13 O.D.)
20278-112R-32	AWG#32 (1.32 O.D.)

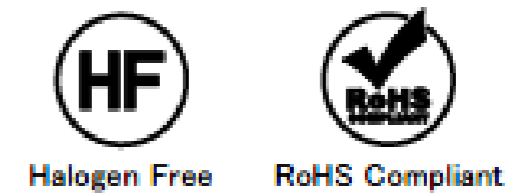
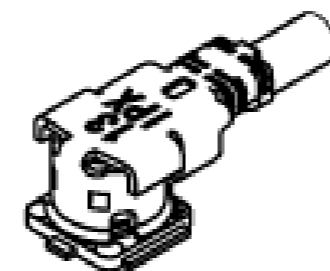
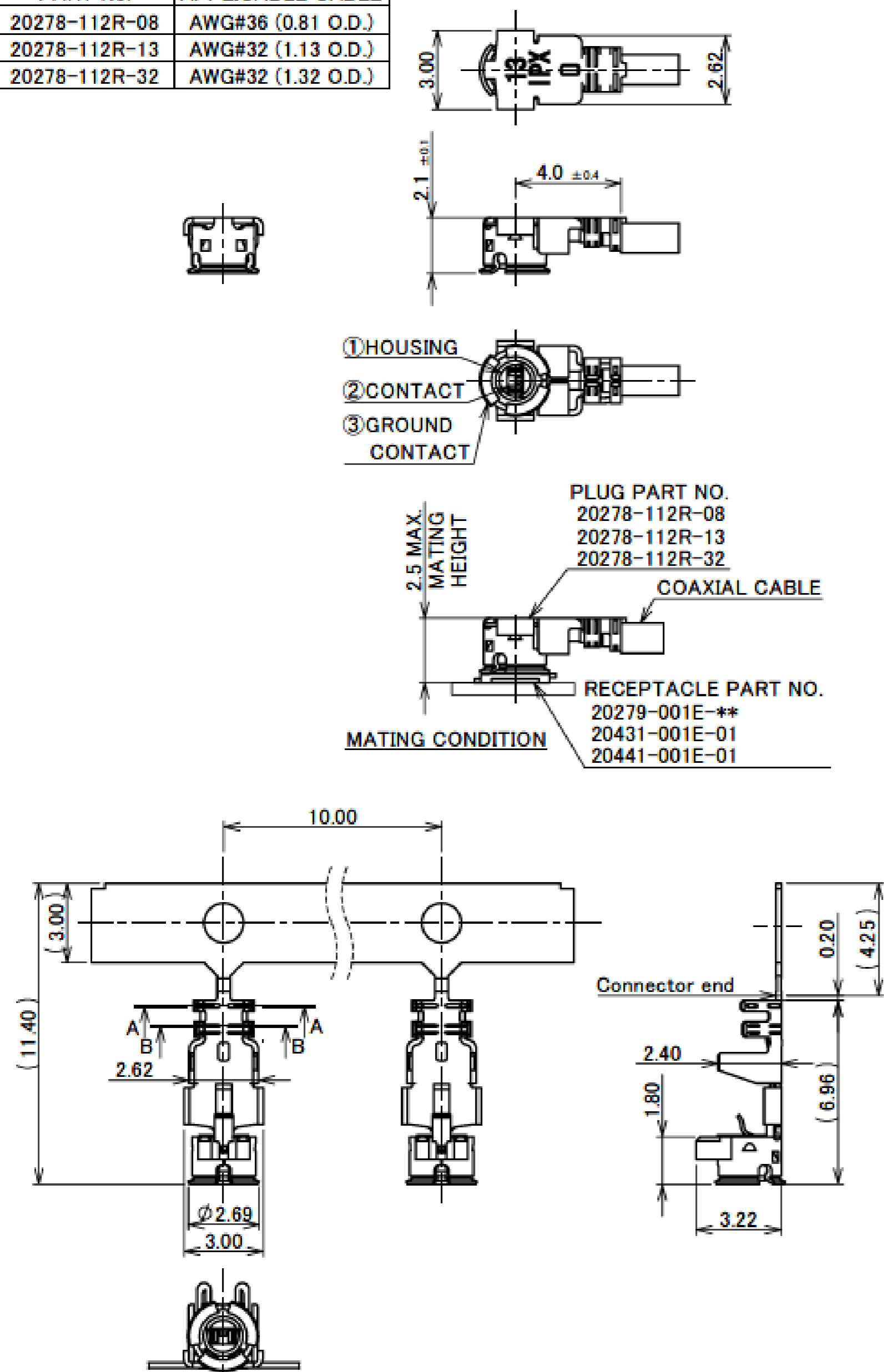

NOTES

- APPLICABLE CONNECTOR:
20279-001E-**, 20431-001E-01, 20441-001E-01
- PERMISSIBLE LOAD OF CABLE AT MATING
- SUGGESTIONS FOR MATING & UNMATING OPERATION.
 - MATING
PLEASE MATE THE CONNECTOR STRAIGHTLY TO VERTICAL DIRECTION AS MUCH AS POSSIBLE. ADJUSTING THE MATING AXIS OF PLUG AND RECEPTACLE. AS EXCESSIVE SLANT ANGLE MATING MAY BREAK THE CONNECTOR, PLEASE DON'T DO IT.
 - UNMATING
 - IN CASE OF UNMATING BY PULLING TOOL
PLEASE USE THE PULLING TOOL AS THE FOLLOWING DRAWING, AND PLEASE PULL PLUG TO VERTICAL DIRECTION AS DIRECTLY AS POSSIBLE.
 - IN CASE OF UNMATING DIRECTLY BY HAND
PLEASE CATCH THE CATCHING AREA OF PLUG, AND PLEASE PULL PLUG TO VERTICAL DIRECTION AS DIRECTLY AS POSSIBLE.
 - CRIMP OVER STANDARDS OF OUTER CONDUCTOR
STANDARDS: LESS THAN 10% FROM TOTAL NUMBERS OF OUTER CONDUCTOR.
(NUMBERS OF OUTER CONDUCTOR'S CRIMP OVER FROM OUTER CONDUCTOR'S BARREL)
- CAUTION ABOUT HEAT SHRINKAGE TUBES
PLEASE BE CAREFUL NOT TO MELT HOUSING WHEN USING HEAT SHRINKAGE TUBES. IT WILL BECOME CAUSE OPEN CIRCUIT.
- THIS IS "Pb-FREE" CONNECTOR.

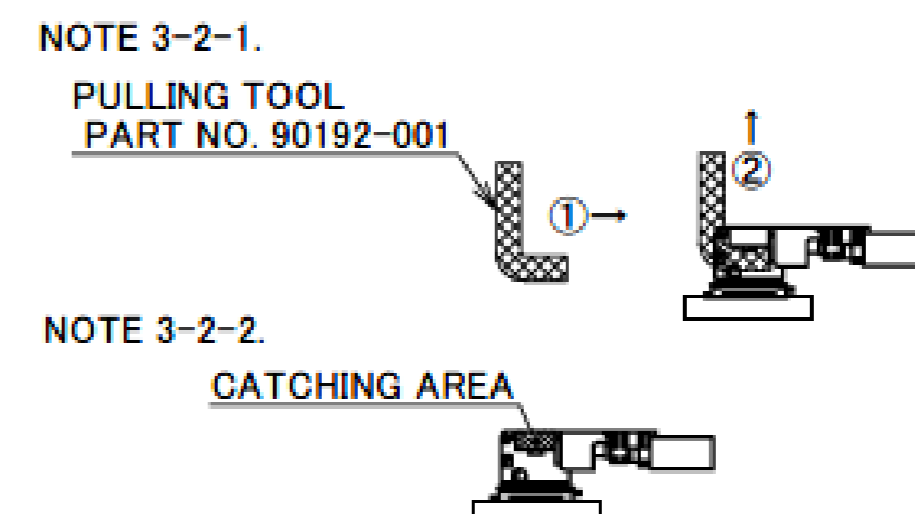
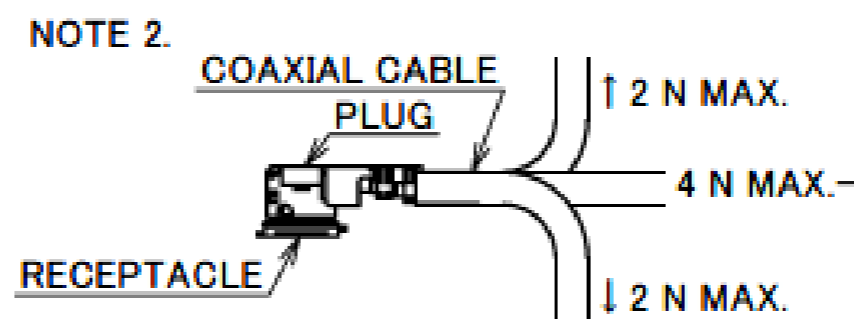

NO.	DESCRIPTION	MATERIAL	FINISH, REMARKS
3	GROUND CONTACT	PHOSPHOR BRONZE	ALL OVER Ni 1.00 μm MIN. CONTACT PART Au 0.05 μm MIN.
2	CONTACT	PHOSPHOR BRONZE	ALL OVER Ni 1.00 μm MIN. CONTACT PART Au 0.10 μm MIN.
1	HOUSING	PBT	UL94V-0, 20278-112R-08: WHITE 20278-112R-13, -32: BLACK

MHF® I plug Au (0.81,1.13,1.32,1.80)

Recommended P/N	20278-112R-**-
PART No.	APPLICABLE CABLE
20278-112R-18	AWG#30 (1.80 O.D.)

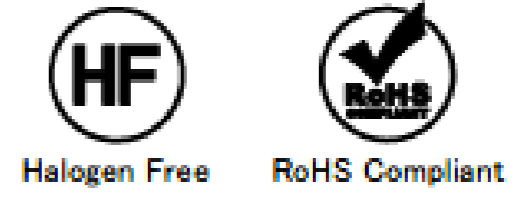
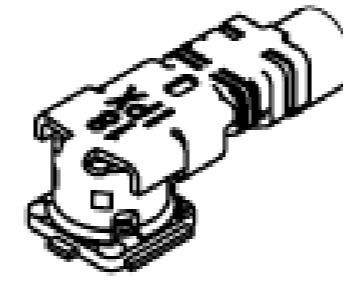
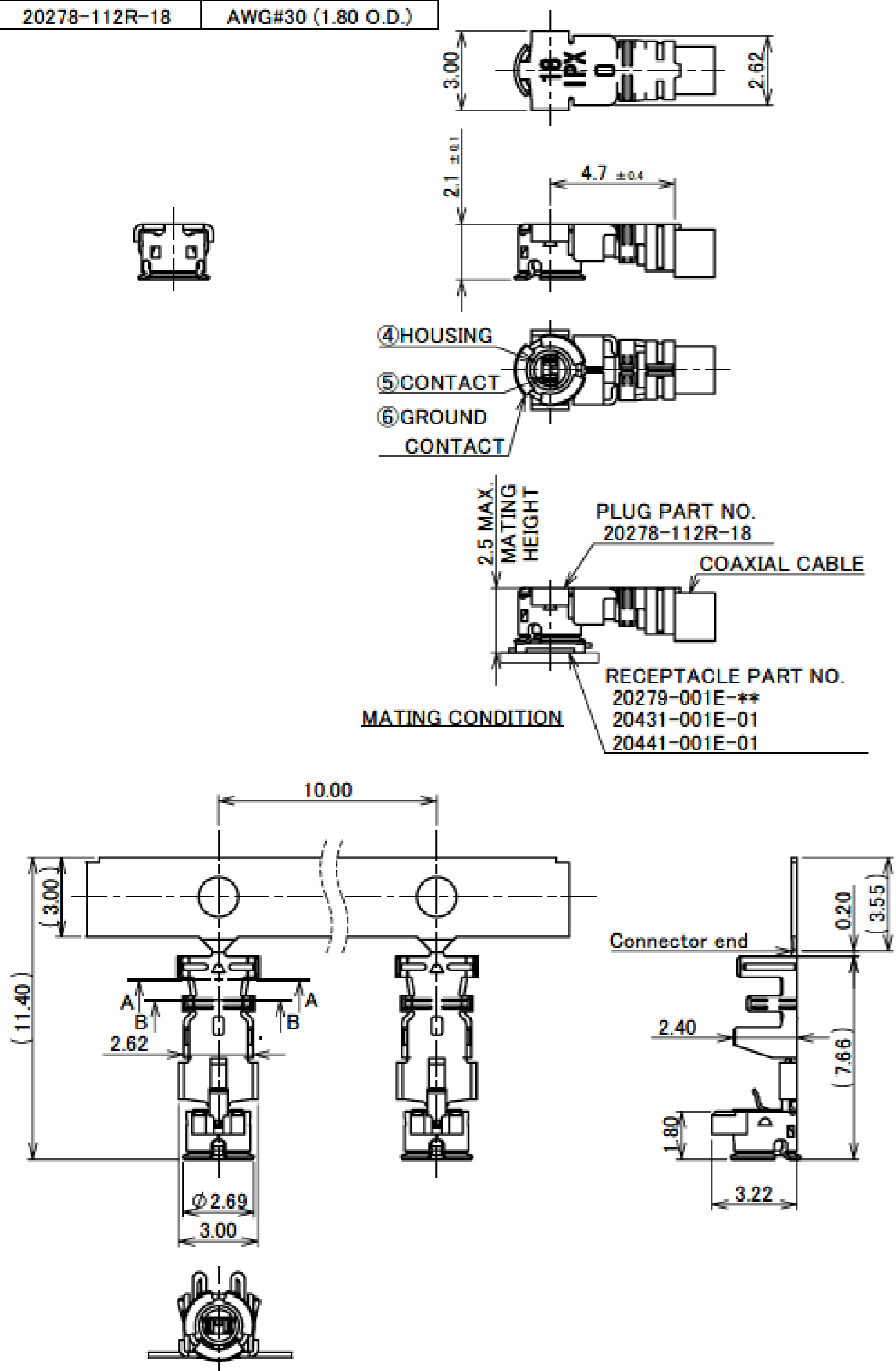

- NOTES
- APPLICABLE CONNECTOR:
20279-001E-**-, 20431-001E-01, 20441-001E-01
 - PERMISSIBLE LOAD OF CABLE AT MATING
 - SUGGESTIONS FOR MATING & UNMATING OPERATION.
 - MATING
PLEASE MATE THE CONNECTOR STRAIGHTLY TO VERTICAL DIRECTION AS MUCH AS POSSIBLE. ADJUSTING THE MATING AXIS OF PLUG AND RECEPTACLE. AS EXCESSIVE SLANT ANGLE MATING MAY BREAK THE CONNECTOR, PLEASE DON'T DO IT.
 - UNMATING
 - IN CASE OF UNMATING BY PULLING TOOL
PLEASE USE THE PULLING TOOL AS THE FOLLOWING DRAWING, AND PLEASE PULL PLUG TO VERTICAL DIRECTION AS DIRECTLY AS POSSIBLE.
 - IN CASE OF UNMATING DIRECTLY BY HAND
PLEASE CATCH THE CATCHING AREA OF PLUG, AND PLEASE PULL PLUG TO VERTICAL DIRECTION AS DIRECTLY AS POSSIBLE.
 - CRIMP OVER STANDARDS OF OUTER CONDUCTOR
STANDARDS: LESS THAN 10% FROM TOTAL NUMBERS OF OUTER CONDUCTOR.
(NUMBERS OF OUTER CONDUCTOR'S CRIMP OVER FROM OUTER CONDUCTOR'S BARREL)
 - CAUTION ABOUT HEAT SHRINKAGE TUBES
PLEASE BE CAREFUL NOT TO MELT HOUSING WHEN USING HEAT SHRINKAGE TUBES. IT WILL BECOME CAUSE OPEN CIRCUIT.
 - THIS IS "Pb-FREE" CONNECTOR.

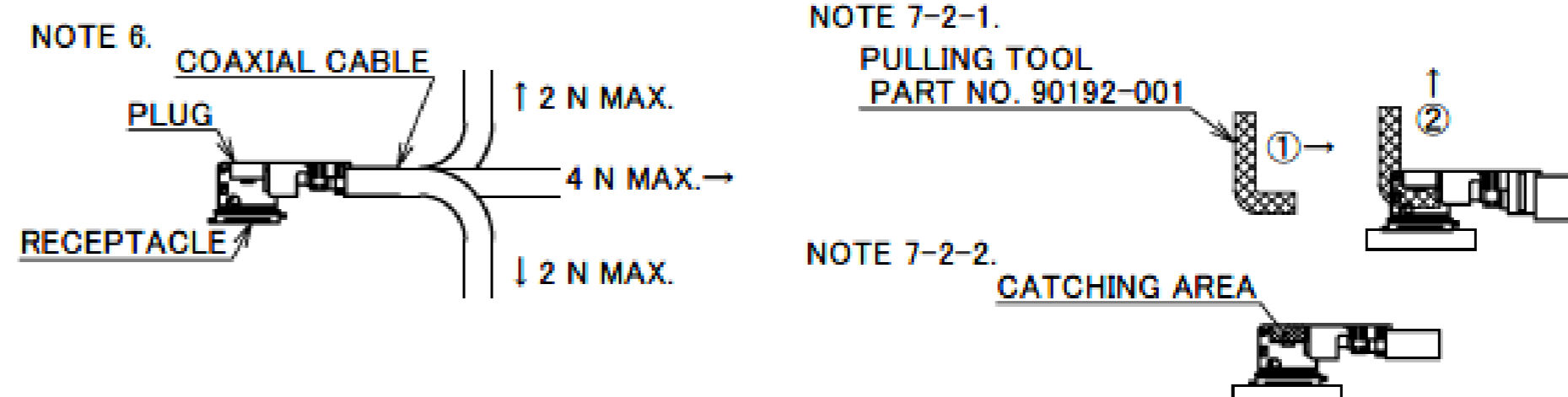

NO.	DESCRIPTION	MATERIAL	FINISH, REMARKS
6	GROUND CONTACT	PHOSPHOR BRONZE	ALL OVER Ni 1.00 μm MIN. CONTACT PART Au 0.05 μm MIN.
5	CONTACT	PHOSPHOR BRONZE	ALL OVER Ni 1.00 μm MIN. CONTACT PART Au 0.10 μm MIN.
4	HOUSING	PBT	UL94V-0, WHITE

Rev.32

Recommended P/N	20278-112R-**-
-----------------	----------------

PART NO.	20278-112R-08	20278-112R-13	20278-112R-32	20278-112R-18	CABLE CUT LENGTH
APPLICABLE CABLE NOMINAL DIMENSION	 2.09 ±0.1 1.25 ±0.1 1.16 ±0.1 AWG #36(7/0.05)	 2.09 ±0.1 1.25 ±0.1 1.16 ±0.1 AWG #32(7/0.08)	 2.09 ±0.1 1.25 ±0.1 1.16 ±0.1 AWG #32(7/0.08)	 2.09 ±0.1 1.25 ±0.1 1.16 ±0.1 AWG #30(7/0.102)	
INNER CONDUCTOR SILVER PLATING					
INNER CONDUCTOR NOMINAL	φ0.40	φ0.68	φ0.66	φ0.84	
DIELECTRIC CORE NOMINAL	(φ0.65)	(φ0.93)	(φ1.12)	(φ1.35)	
OUTER CONDUCTOR SILVER OR TIN PLATING	φ0.81	φ1.13	φ1.32	φ1.80	
JACKET					
BRAIDED SHIELD OF OUTER CONDUCTOR	SINGLE	SINGLE	DOUBLE	SINGLE	
PART NO. OF SEMI AUTO TERMINATION MACHINE	90213-008C	90213-013C	90213-032C	90232-018	
SECT. B-B					
SECT. A-A					
CRIMP HEIGHT	CH-1	1.34~1.40	1.34~1.40	1.34~1.40	
	CH-2	0.76~0.84	1.06~1.14	1.20~1.30	
	CH-3	0.85~0.97	1.15~1.35	1.26~1.46	

NOTE 9. DO NOT USE SOLDER COATED EITHER INNER OR OUTER CONDUCTOR CABLE.

Rev.32

MHF® I plug Au (0.81,1.13,1.32,1.80)

ITEMS	SPECIFICATION	
RECOMMENDED APPLICABLE CONNECTOR PART No.	20279-001E-**	20441-001E-01
RATING VOLTAGE	60 V AC (R.M.S)	
RATING FREQUENCY	DC~9GHz	
OPERATING TEMPERATURE	233~363 K (-40°C~+90°C)	
VSWR (MATED WITH SMA ADAPTER PART No.90193-001)	1.30 MAX. AT 0.1~3 GHz, 1.50 MAX. AT 3~6 GHz, 1.90 MAX. AT 6~9 GHz (0.81 O.D. / 1.13 O.D. / 1.80 O.D.) 1.30 MAX. AT 0.1~3 GHz, 1.50 MAX. AT 3~6 GHz, 1.60 MAX. AT 6~9 GHz (1.32 O.D.)	
MAIN CONTACT RESISTANCE	INITIAL: 20 mohm MAX. / AFTER TEST: 25 mohm MAX.	
GROUND CONTACT RESISTANCE	INITIAL: 10 mohm MAX. / AFTER TEST: 15 mohm MAX.	
INSULATION RESISTANCE	INITIAL: 500 Mohm MIN. / AFTER TEST: 100 Mohm MIN.	
DIELECTRIC WITHSTANDING VOLTAGE	200 V AC, 1 MINUTE	
DURABILITY	30 CYCLES	
UNMATING FORCE (INITIAL / AFTER TEST)	5 N MIN. / 3 N MIN.	
CRIMP STRENGTH	20278-112R-08, 20278-112R-13, 20278-112R-32: 10 N MIN. 20278-112R-18: 15 N MIN.	
PRODUCT SPECIFICATION	PRS-1676	
TEST REPORT	TR-12044	
PACKING STANDARD	300-233	
INSTRUCTION MANUAL	HIM-10002	
APPEARANCE CRITERIA No.	QLS-A***	

Rev.32

MHF® I plug Au (1.37)

Recommended P/N	20351-112R-37
PART No.	20351-112R-37

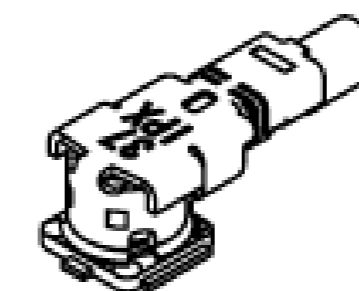
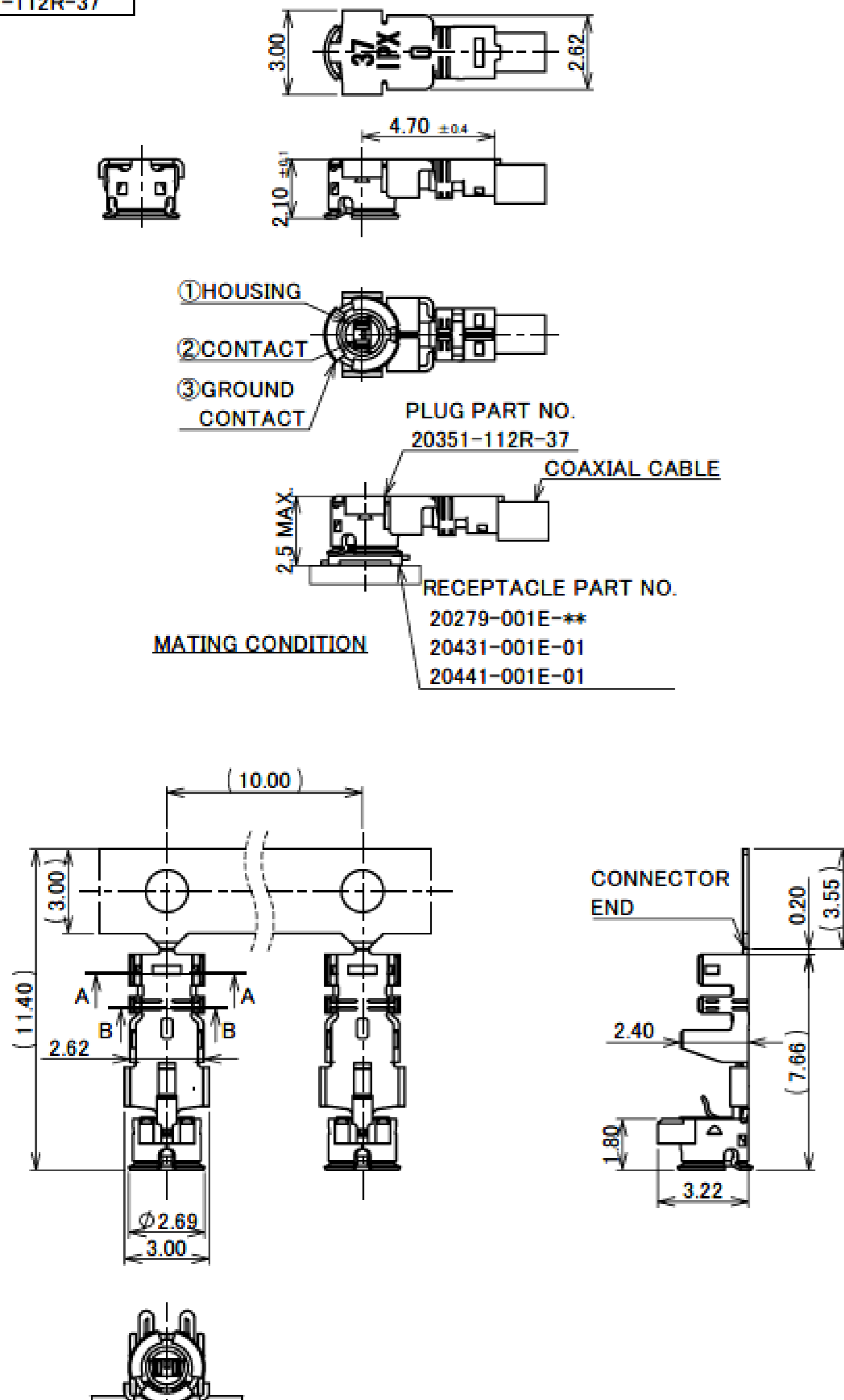

Halogen Free RoHS Compliant

NOTES

1. APPLICABLE CONNECTOR:
20279-001E-**, 20431-001E-01, 20441-001E-01
2. PERMISSIBLE LOAD OF CABLE AT MATING
3. SUGGESTIONS FOR MATING & UNMATING OPERATION
 - 3-1. MATING
PLEASE MATE THE CONNECTOR STRAIGHTLY TO VERTICAL DIRECTION AS MUCH AS POSSIBLE, ADJUSTING THE MATING AXIS OF PLUG AND RECEPTACLE. AS EXCESSIVE SLANT ANGLE MATING MAY BREAK THE CONNECTOR, PLEASE DON'T DO IT.
 - 3-2. UNMATING
 - 3-2-1. IN CASE OF UNMATING BY PULLING TOOL
PLEASE USE THE PULLING TOOL AS THE FOLLOWING DRAWING, AND PLEASE PULL PLUG TO VERTICAL DIRECTION AS DIRECTLY AS POSSIBLE.
 - 3-2-2. IN CASE OF UNMATING DIRECTLY BY HAND
PLEASE CATCH THE CATCHING AREA OF PLUG, AND PLEASE PULL PLUG TO VERTICAL DIRECTION AS DIRECTLY AS POSSIBLE.
 - 3-3. CRIMP OVER STANDARDS OF OUTER CONDUCTOR
STANDARDS: LESS THAN 10% FROM TOTAL NUMBERS OF OUTER CONDUCTOR.
(NUMBERS OF OUTER CONDUCTOR'S CRIMP OVER FROM OUTER CONDUCTOR'S BARREL)
 - 3-4. CAUTION ABOUT HEAT SHRINKAGE TUBES
PLEASE BE CAREFUL NOT TO MELT HOUSING WHEN USING HEAT SHRINKAGE TUBES. IT WILL BECOME CAUSE OPEN CIRCUIT.
4. TIP OF CONTACT SHOULD BE RECESSED OF HOUSING AFTER CRIMPED ABOUT MATING AREA.
5. THIS IS "Pb-FREE" CONNECTOR.

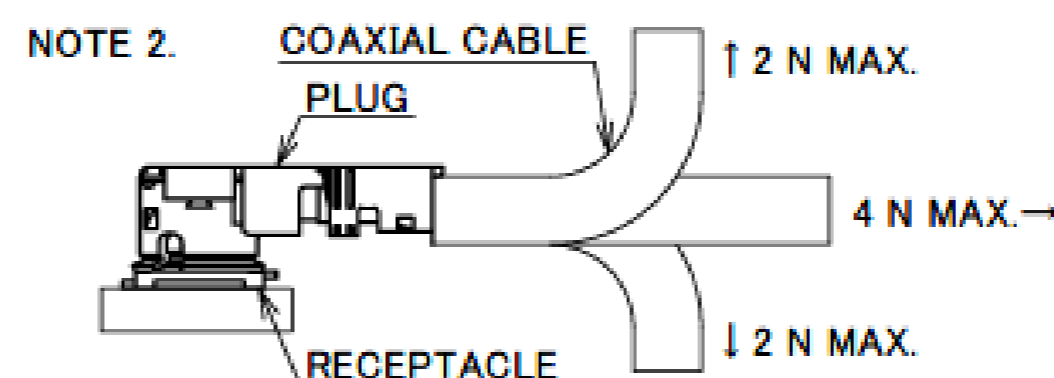

NOTE 3-2-1.

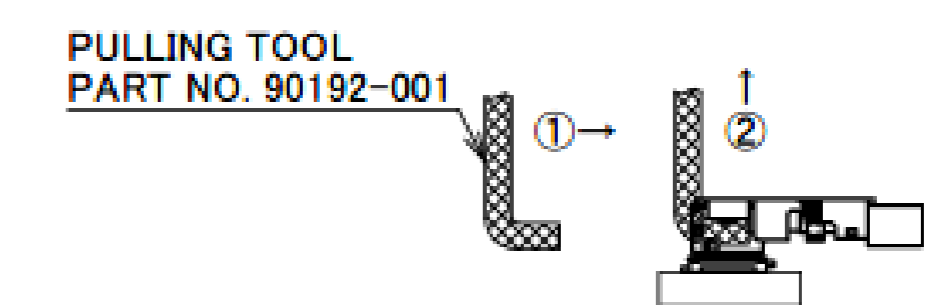

NOTE 3-2-2.

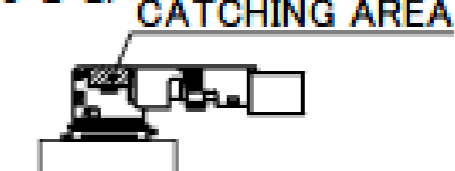

NO.	DESCRIPTION	MATERIAL	FINISH, REMARKS
3	GROUND CONTACT	PHOSPHOR BRONZE	ALL OVER Ni 1.00 μm MIN. CONTACT PART Au 0.05 μm MIN.
2	CONTACT	PHOSPHOR BRONZE	ALL OVER Ni 1.00 μm MIN. CONTACT PART Au 0.10 μm MIN.
1	HOUSING	PBT	UL94V-0, WHITE

Rev.20

MHF® I plug Au (1.37)

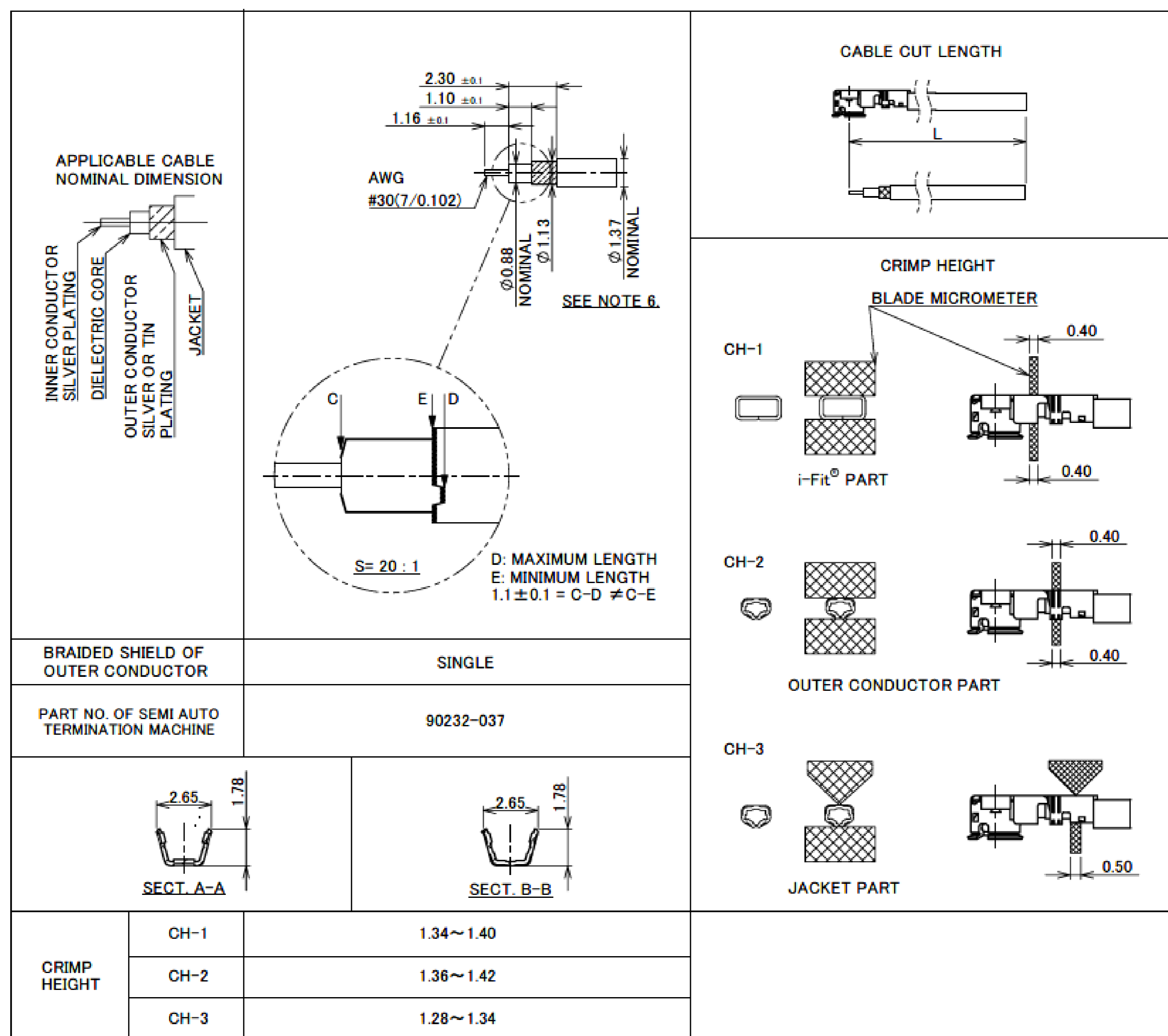

NOTE 6. DO NOT USE SOLDER COATED EITHER INNER OR OUTER CONDUCTOR CABLE.

Rev.20

ITEMS	SPECIFICATION	
RECOMMENDED APPLICABLE CONNECTOR PART No.	20279-001E-**	20441-001E-01
RATING VOLTAGE	60 V AC (R.M.S)	
RATING FREQUENCY	DC ~ 9GHz	
OPERATING TEMPERATURE	233 ~ 363 K (-40°C ~ +90°C)	
VSWR	1.3 MAX. AT 0.1 ~ 3 GHz, 1.5 MAX. AT 3 ~ 6 GHz, 1.9 MAX. AT 6 ~ 9 GHz	
MAIN CONTACT RESISTANCE	INITIAL: 20 mohm MAX. / AFTER TEST: 25 mohm MAX.	
GROUND CONTACT RESISTANCE	INITIAL: 10 mohm MAX. / AFTER TEST: 15 mohm MAX.	
INSULATION RESISTANCE	INITIAL: 500 Mohm MIN. / AFTER TEST: 100 Mohm MIN.	
DIELECTRIC WITHSTANDING VOLTAGE	200 V AC, 1 MINUTE	
DURABILITY	30 CYCLES	
UNMATING FORCE (INITIAL / AFTER TEST)	5 N MIN. / 3 N MIN.	
CRIMP STRENGTH	15 N MIN.	
PRODUCT SPECIFICATION	PRS-1726	
TEST REPORT	TR-12096	
PACKING STANDARD	300-233	
INSTRUCTION MANUAL	HIM-10002	
APPEARANCE CRITERIA No.	QLS-A***	

Rev.20

MHF® I plug Ni top (0.81,1.13,1.32,1.37,1.80)

Recommended P/N **20670-001R-**-**

PART NO.
20670-001R-08
20670-001R-13
20670-001R-32

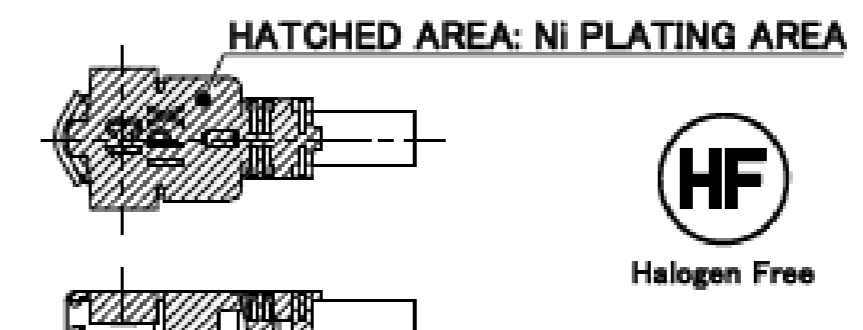
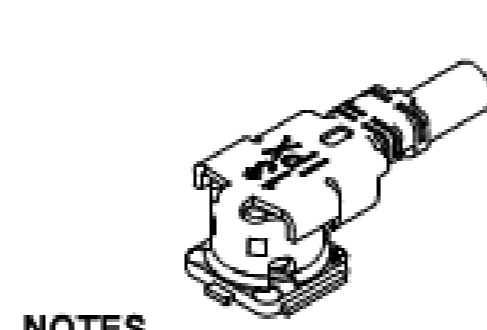
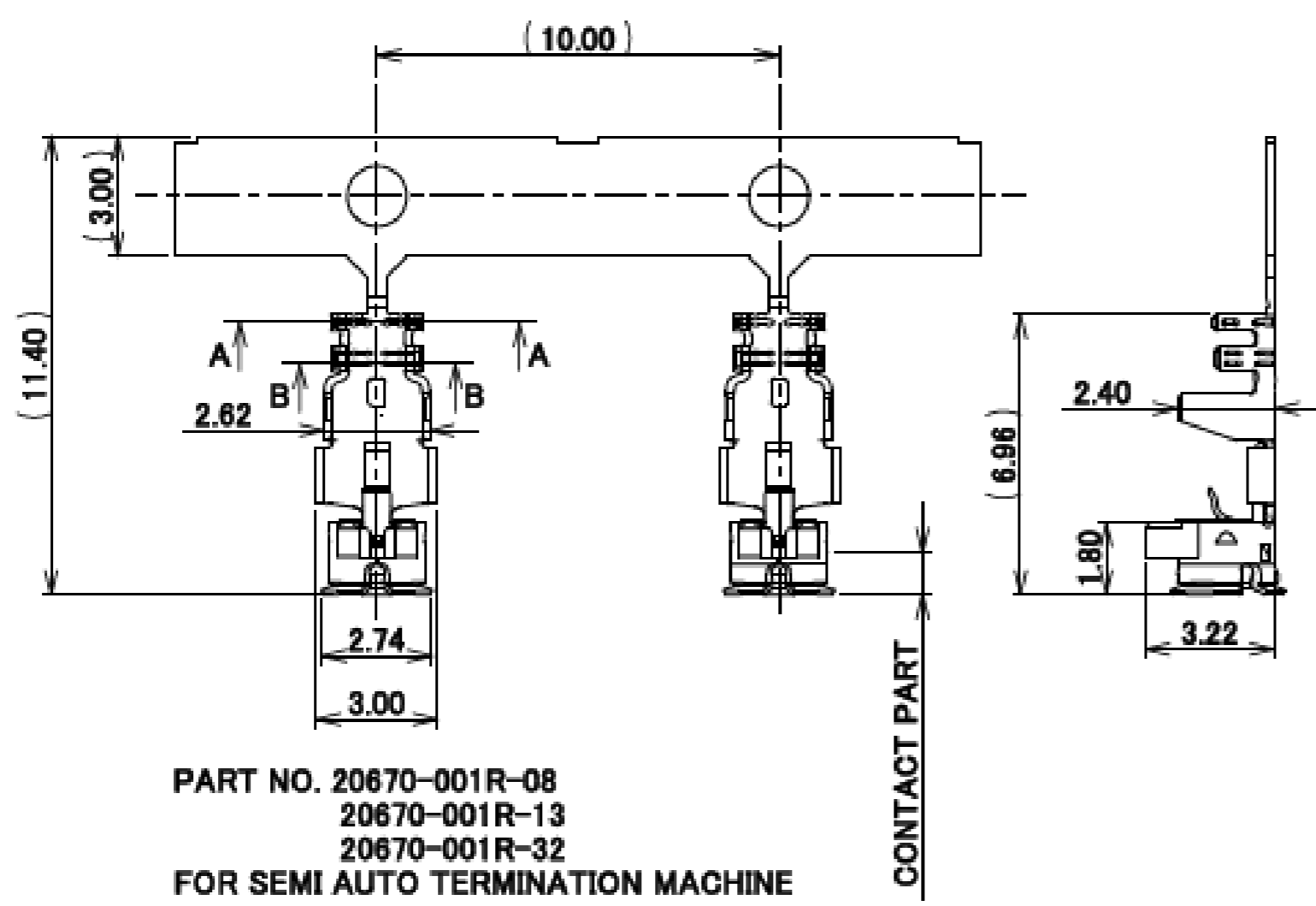
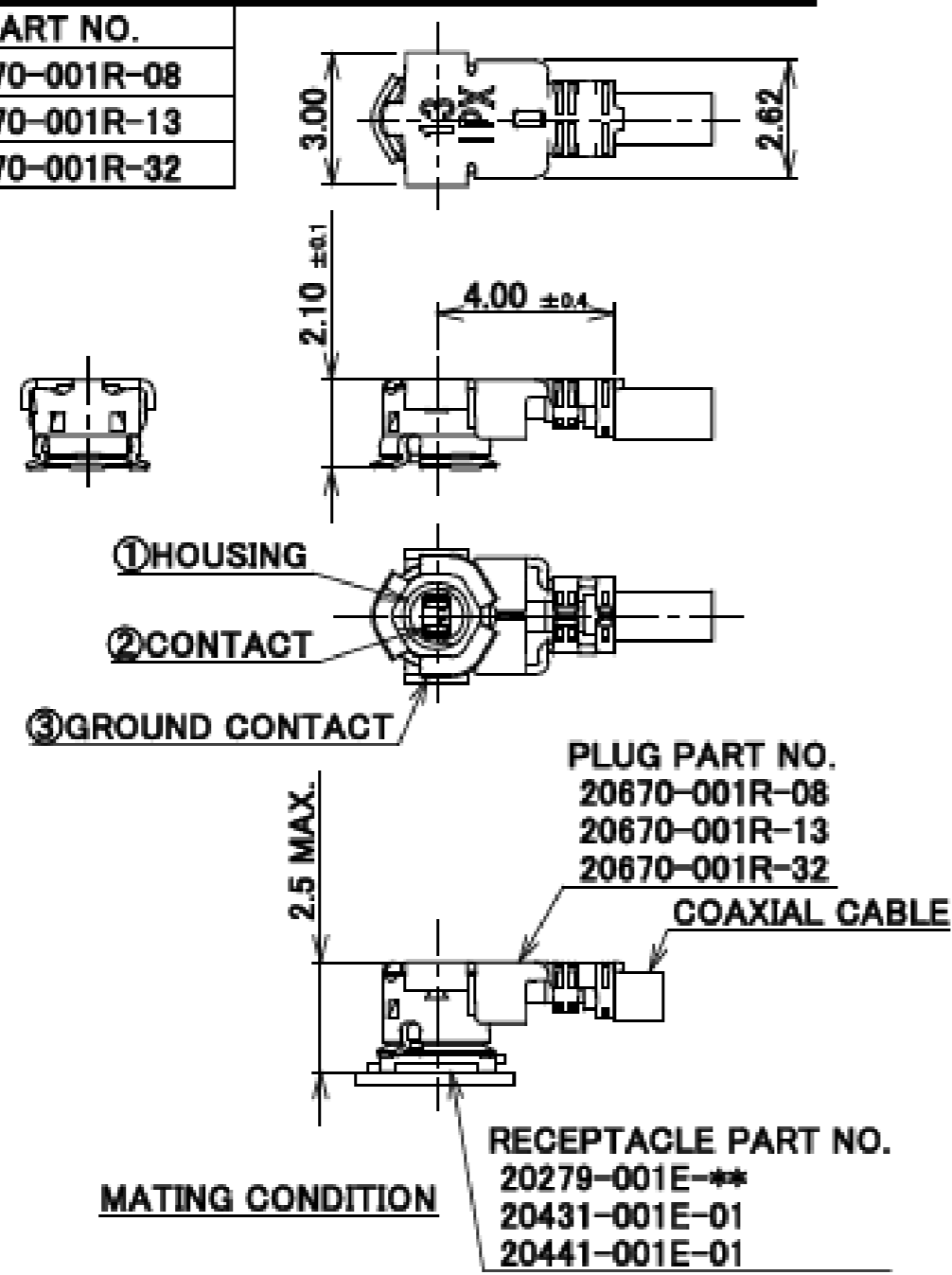

NOTES

- APPLICABLE CONNECTOR:
20279-001E-**-
20431-001E-01
20441-001E-01
- PERMISSIBLE LOAD OF CABLE AT MATING
- MATING AND UNMATING INSTRUCTION
- MATING
MAKE THE CONNECTOR VERTICALLY AS MUCH AS POSSIBLE, ADJUSTING THE MATING AXIS OF PLUG AND RECEPTACLE.
- UNMATING
- UNMATING BY PULLING TOOL (PART NO. 90192-001): USE THE PULLING TOOL AS THE FOLLOWING DRAWING, AND PULL PLUG TO VERTICAL DIRECTION AS DIRECTLY AS POSSIBLE.
- UNMATING DIRECTLY BY HAND: CATCH THE CATCHING AREA OF PLUG, AND PULL PLUG TO VERTICAL DIRECTION AS DIRECTLY AS POSSIBLE.
- CRIMP OVER STANDARDS OF OUTER CONDUCTOR
STANDARDS: LESS THAN 10% FROM TOTAL NUMBERS OF OUTER CONDUCTOR.
(NUMBERS OF OUTER CONDUCTOR'S CRIMP OVER FROM OUTER CONDUCTOR'S BARREL)
- CAUTION ABOUT HEAT SHRINKAGE TUBES
PLEASE BE CAREFUL NOT TO MELT HOUSING WHEN USING HEAT SHRINKAGE TUBES.
IT WILL CAUSE OPEN CIRCUIT.
- THIS IS "Pb-FREE" CONNECTOR.

NOTE 2.

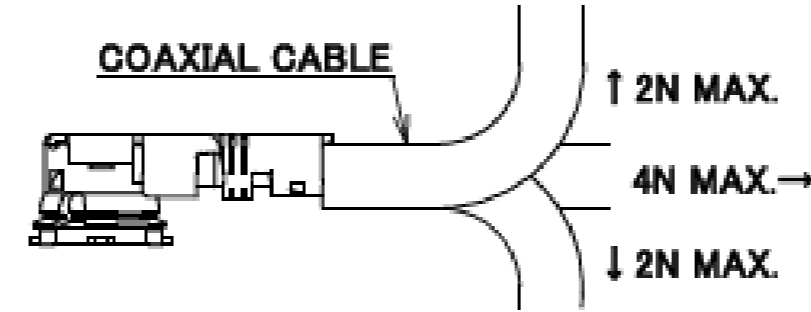

NOTE 3-2-1.

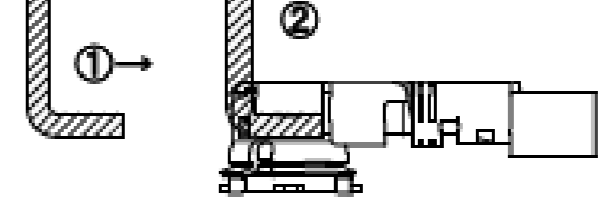

NOTE 3-2-2.

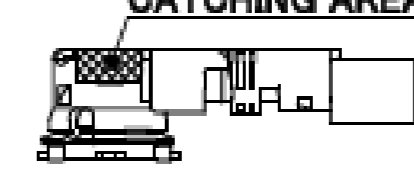

NO.	DESCRIPTION	MATERIAL	FINISH, REMARKS
3	GROUND CONTACT	PHOSPHOR BRONZE	ALL OVER Ni 1.00 μm MIN. CONTACT PART Au 0.02 μm MIN. [Ni PLATING AREA] Ni ONLY
2	CONTACT	PHOSPHOR BRONZE	ALL OVER Ni 1.00 μm MIN. CONTACT PART Au 0.03 μm MIN.
1	HOUSING	PBT	UL94V-0, BLACK

Rev.7

Recommended P/N **20670-001R-**-**

PART No.
20670-001R-18

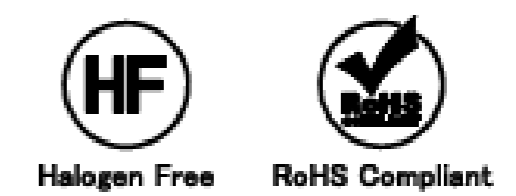
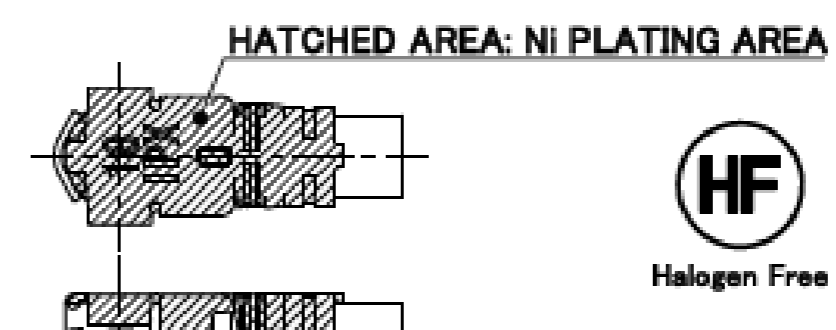
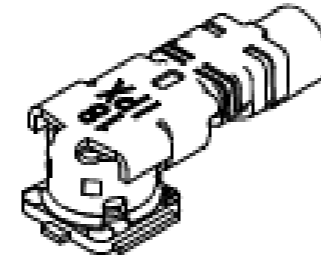
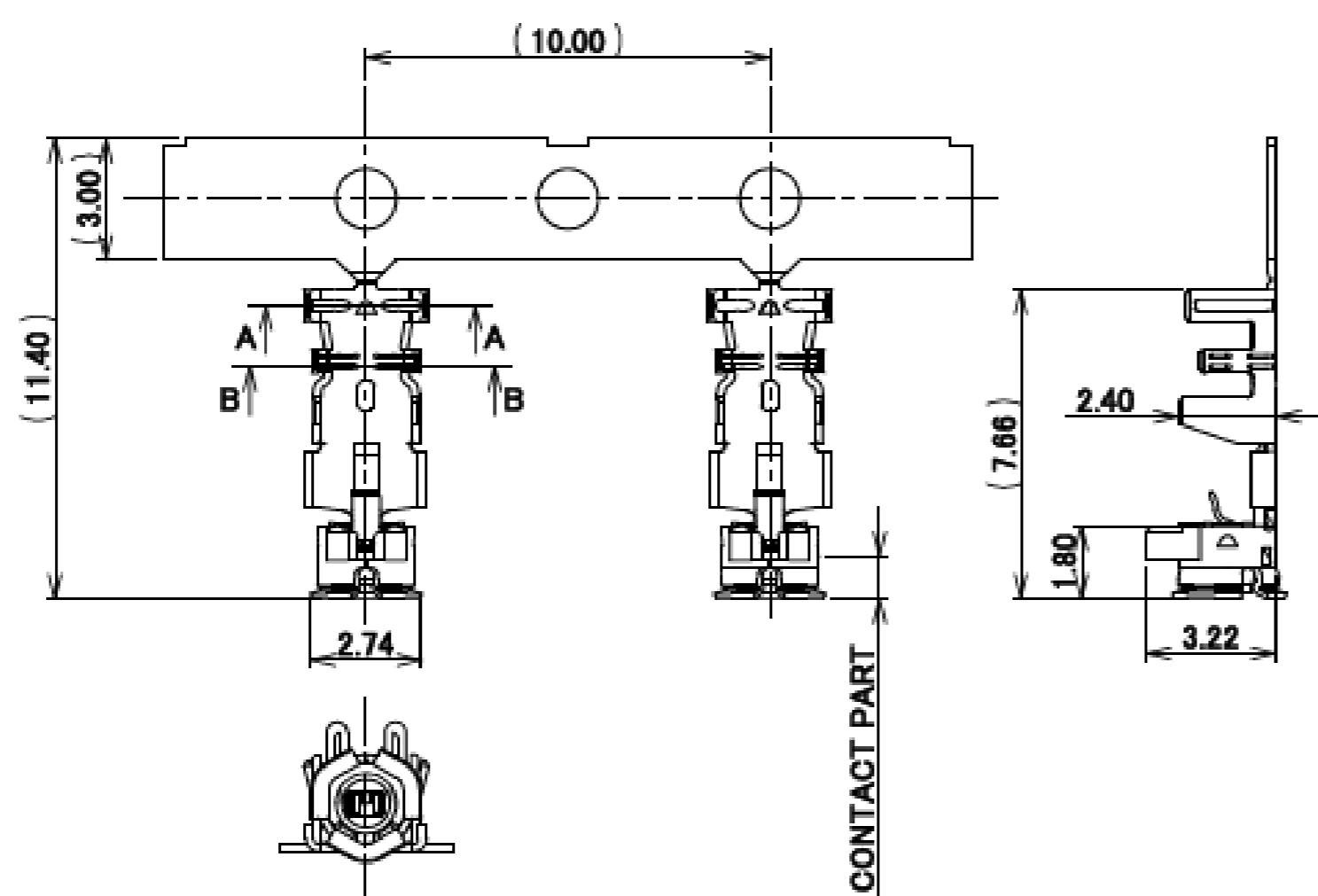
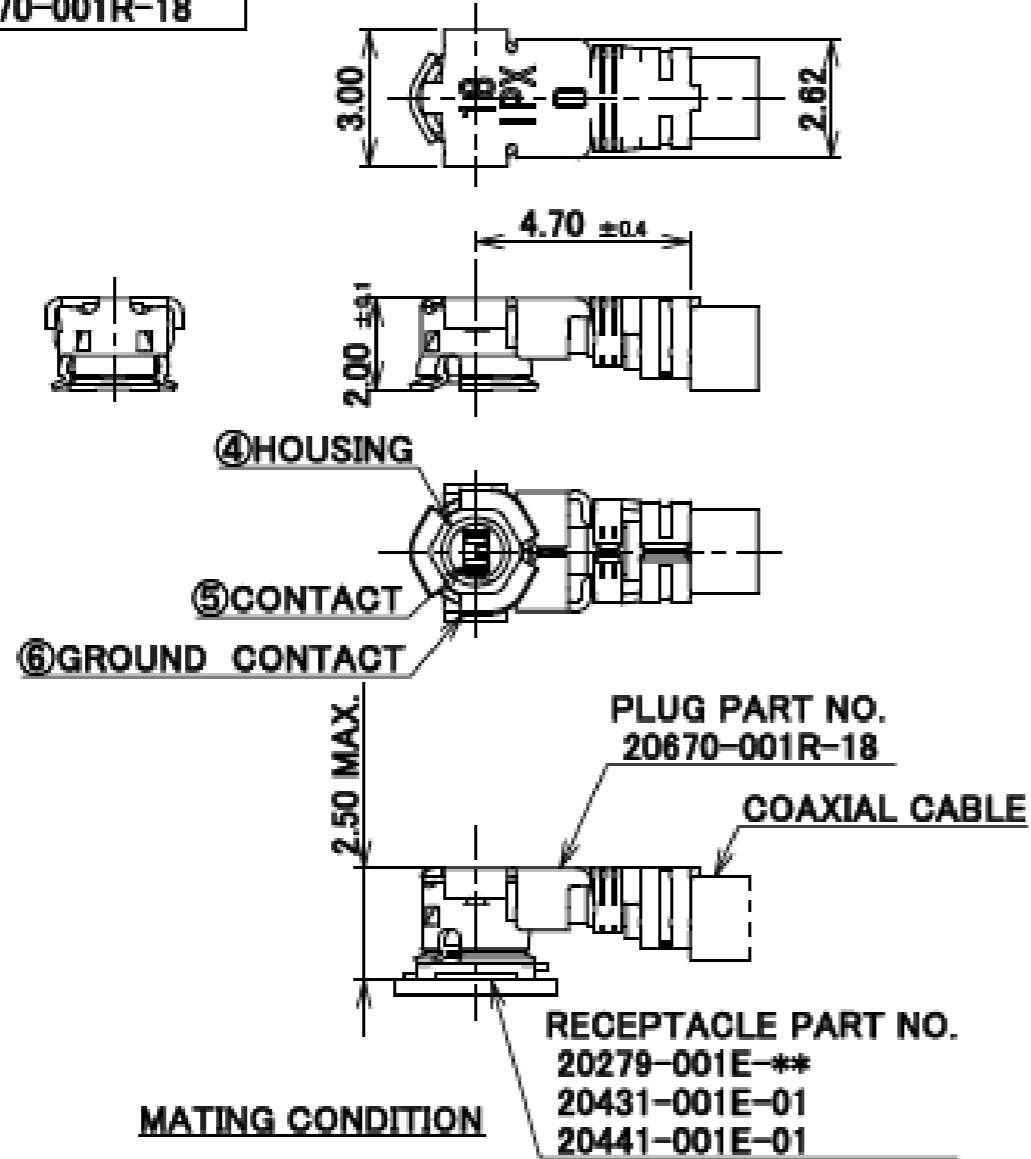

NOTES

- APPLICABLE CONNECTOR:
20279-001E-**-
20431-001E-01
20441-001E-01
- PERMISSIBLE LOAD OF CABLE AT MATING
- MATING AND UNMATING INSTRUCTION
- MATING
MAKE THE CONNECTOR VERTICALLY AS MUCH AS POSSIBLE, ADJUSTING THE MATING AXIS OF PLUG AND RECEPTACLE.
- UNMATING
- UNMATING BY PULLING TOOL (PART NO. 90192-001): USE THE PULLING TOOL AS THE FOLLOWING DRAWING, AND PULL PLUG TO VERTICAL DIRECTION AS DIRECTLY AS POSSIBLE.
- UNMATING DIRECTLY BY HAND: CATCH THE CATCHING AREA OF PLUG, AND PULL PLUG TO VERTICAL DIRECTION AS DIRECTLY AS POSSIBLE.
- CRIMP OVER STANDARDS OF OUTER CONDUCTOR
STANDARDS: LESS THAN 10% FROM TOTAL NUMBERS OF OUTER CONDUCTOR.
(NUMBERS OF OUTER CONDUCTOR'S CRIMP OVER FROM OUTER CONDUCTOR'S BARREL)
- CAUTION ABOUT HEAT SHRINKAGE TUBES
PLEASE BE CAREFUL NOT TO MELT HOUSING WHEN USING HEAT SHRINKAGE TUBES.
IT WILL CAUSE OPEN CIRCUIT.
- THIS IS "Pb-FREE" CONNECTOR.

NOTE 6.

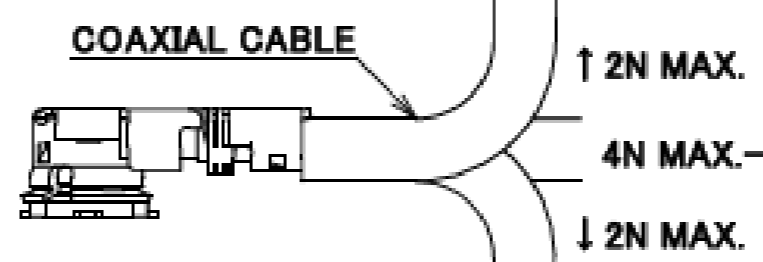

NOTE 7-2-1.

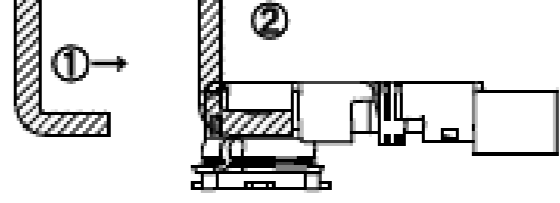

NOTE 7-2-2.



NO.	DESCRIPTION	MATERIAL	FINISH, REMARKS
6	GROUND CONTACT	PHOSPHOR BRONZE	ALL OVER Ni 1.00 μm MIN. CONTACT PART Au 0.02 μm MIN. [Ni PLATING AREA] Ni ONLY
5	CONTACT	PHOSPHOR BRONZE	ALL OVER Ni 1.00 μm MIN. CONTACT PART Au 0.03 μm MIN.
4	HOUSING	PBT	UL94V-0, BLACK

Rev.7

MHF® I plug Ni top (0.81,1.13,1.32,1.37,1.80)

Recommended P/N	20670-001R-**-
PART No.	20670-001R-37

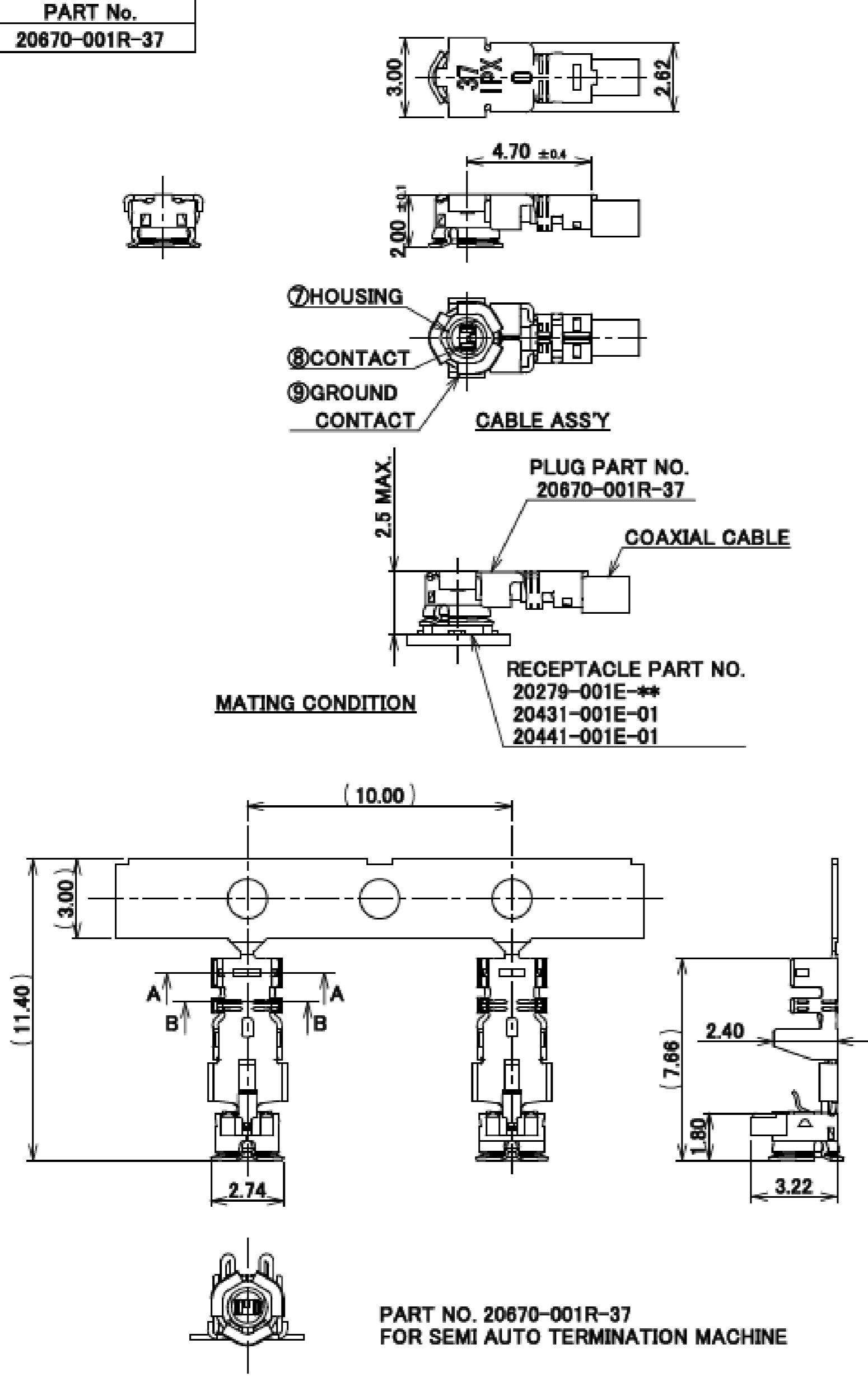

NOTES

9. APPLICABLE CONNECTOR:
20279-001E-**-
20431-001E-01
20441-001E-01

10. PERMISSIBLE LOAD OF CABLE AT MATING

11. MATING AND UNMATING INSTRUCTION

11-1. MATING
MAKE THE CONNECTOR VERTICALLY AS MUCH AS POSSIBLE, ADJUSTING THE MATING AXIS OF PLUG AND RECEPTACLE.

11-2. UNMATING
11-2-1. IN CASE OF UNMATING BY PULLING TOOL (PART NO. 90192-001): USE THE PULLING TOOL AS THE FOLLOWING DRAWING, AND PULL PLUG TO VERTICAL DIRECTION AS DIRECTLY AS POSSIBLE.
11-2-2. IN CASE OF UNMATING DIRECTLY BY HAND: CATCH THE CATCHING AREA OF PLUG, AND PULL PLUG TO VERTICAL DIRECTION AS DIRECTLY AS POSSIBLE.

11-3. CRIMP OVER STANDARDS OF OUTER CONDUCTOR
STANDARDS: LESS THAN 10% FROM TOTAL NUMBERS OF OUTER CONDUCTOR.
(NUMBERS OF OUTER CONDUCTOR'S CRIMP OVER FROM OUTER CONDUCTOR'S BARREL)

11-4. CAUTION ABOUT HEAT SHRINKAGE TUBES
PLEASE BE CAREFUL NOT TO MELT HOUSING WHEN USING HEAT SHRINKAGE TUBES.
IT WILL CAUSE OPEN CIRCUIT.

12. THIS IS "Pb-FREE" CONNECTOR.

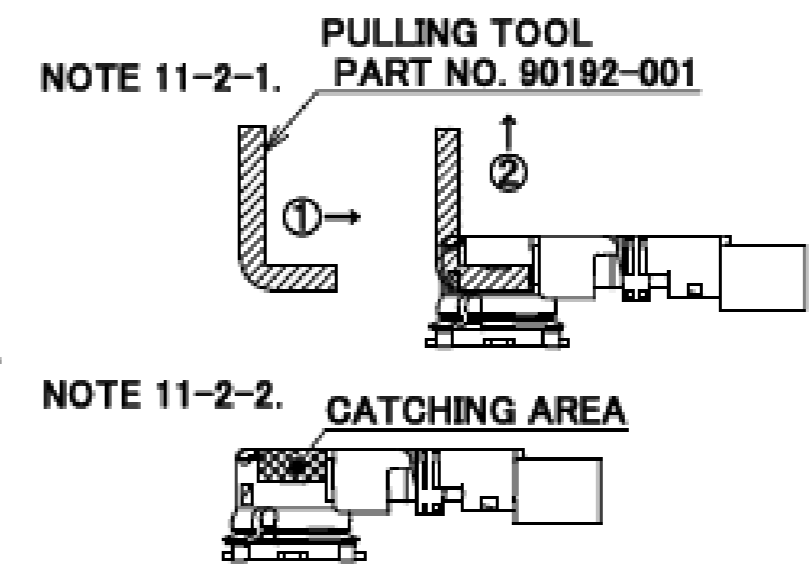
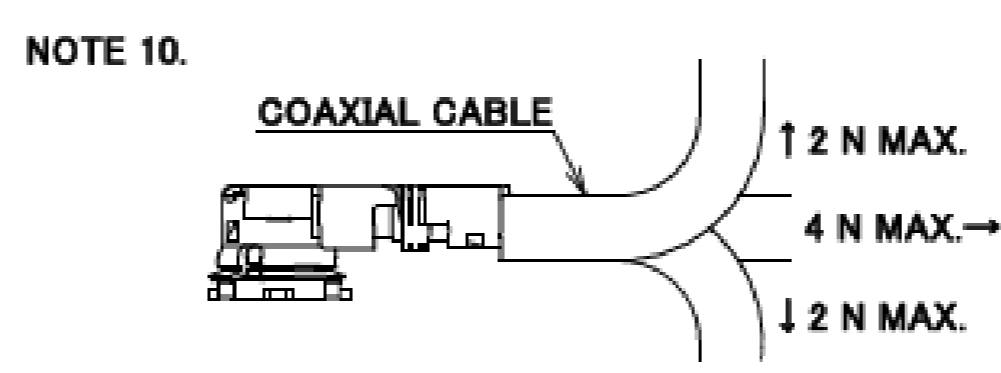

NO.	DESCRIPTION	MATERIAL	FINISH, REMARKS
9	GROUND CONTACT	PHOSPHOR BRONZE	ALL OVER Ni 1.00 μm MIN. CONTACT PART Au 0.02 μm MIN. [Ni PLATING AREA] Ni ONLY
8	CONTACT	PHOSPHOR BRONZE	ALL OVER Ni 1.00 μm MIN. CONTACT PART Au 0.03 μm MIN.
7	HOUSING	PBT	UL94V-0, BLACK

Rev.7

PART NO.	20670-001R-08	20670-001R-13	20670-001R-32	20670-001R-18	CABLE CUT LENGTH
APPLICABLE CABLE NOMINAL DIMENSION					
INNER CONDUCTOR SILVER PLATING DIELECTRIC CORE	*SEE NOTE 14.				
BRAIDED SHIELD OF OUTER CONDUCTOR	SINGLE	SINGLE	DOUBLE	SINGLE	
PART NO. OF SEMI AUTO TERMINATION MACHINE	90213-008C	90213-013C	90213-032C	90232-018	
SECT. B-B					
SECT. A-A					
CRIMP HEIGHT	CH-1	1.34~1.40	1.34~1.40	1.34~1.40	1.34~1.40
	CH-2	0.76~0.84	1.06~1.14	1.20~1.30	1.41~1.49
	CH-3	0.85~0.97	1.15~1.35	1.26~1.46	1.70~1.80

NOTE
13. MUST NOT USE SOLDER COATED INNER CONDUCTOR AND OUTER CONDUCTOR.

Rev.7

MHF® I plug Ni top (0.81,1.13,1.32,1.37,1.80)

PART NO.		20670-001R-37		CABLE CUT LENGTH	
APPLICABLE CABLE NOMINAL DIMENSION					
BRAIDED SHIELD OF OUTER CONDUCTOR		SINGLE		CRIMP HEIGHT BLADE MICROMETER	
PART NO. OF SEMI AUTO TERMINATION MACHINE		90232-037			
SECT. B-B					
SECT. A-A					
CRIMP HEIGHT	CH-1	1.34~1.40			
	CH-2	1.36~1.42			
	CH-3	1.28~1.34			

NOTE
14. MUST NOT USE SOLDER COATED INNER CONDUCTOR AND OUTER CONDUCTOR.

Rev.7

ITEMS	SPECIFICATION
RECOMMENDED APPLICABLE CONNECTOR PART No.	20279-001E-***
RATING VOLTAGE	60 V AC (R.M.S)
RATING FREQUENCY	DC~9GHz
OPERATING TEMPERATURE	233~363 K (-40°C~+90°C)
VSWR (MATED WITH SMA ADAPTER PART No:90193-001)	1.30 MAX. AT 0.1~3 GHz, 1.50 MAX. AT 3~6 GHz, 1.90 MAX. AT 6~9 GHz (0.81 O.D. / 1.13 O.D. / 1.37 O.D. / 1.80 O.D.) 1.30 MAX. AT 0.1~3 GHz, 1.50 MAX. AT 3~6 GHz, 1.80 MAX. AT 6~9 GHz (1.32 O.D.)
MAIN CONTACT RESISTANCE	INITIAL: 20 mohm MAX. / AFTER TEST: Δ R 20 mohm MAX.
GROUND CONTACT RESISTANCE	INITIAL: 20mohm MAX. / AFTER TEST: Δ R 100 mohm MAX.
INSULATION RESISTANCE	INITIAL: 500 Mohm MIN. / AFTER TEST: 100 Mohm MIN.
DIELECTRIC WITHSTANDING VOLTAGE	200 V AC, 1 MINUTE
DURABILITY	30 CYCLES
UNMATING FORCE (INITIAL / AFTER TEST)	5 N MIN. / 3 N MIN.
CRIMP STRENGTH	20670-001R-08, 20670-001R-13, 20670-001R-32: 10 N MIN. 20670-001R-18, 20670-001R-37: 15 N MIN.
PRODUCT SPECIFICATION	PRS-2105
TEST REPORT	TR-15059
PACKING STANDARD	300-233
INSTRUCTION MANUAL	HIM-10002
APPEARANCE CRITERIA No.	QLS-A***

Accessories for MHF® I plug

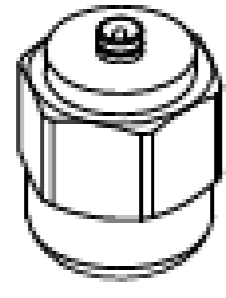

MHF I/II SMA ADAPTOR
PART NO. 90193-001

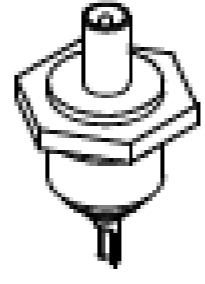

MHF I/II PLUG INSPECTION CONNECTOR
PART NO. 90194-001

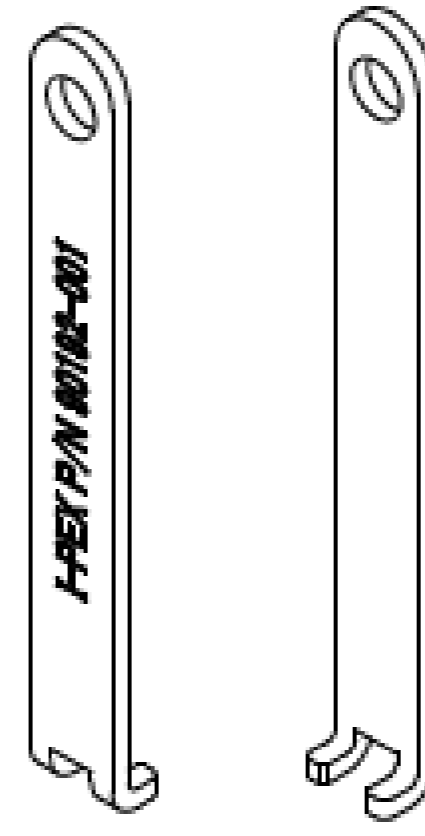

FRONT SIDE BACK SIDE
MHF I/II PULLING TOOL
PART NO. 90192-001

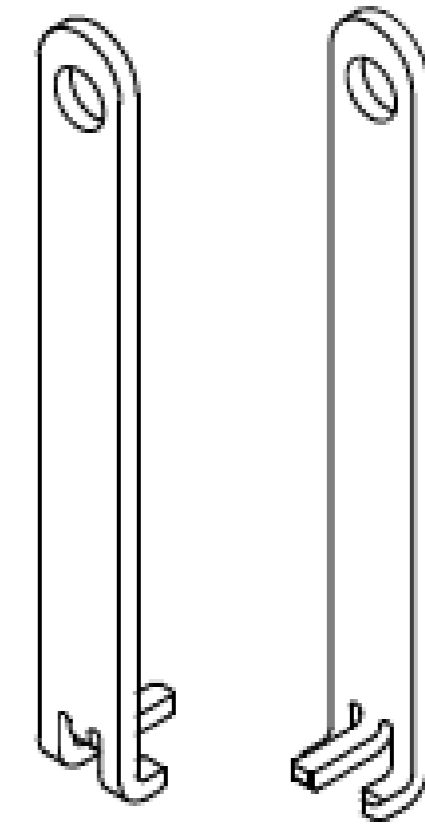

FRONT SIDE BACK SIDE
MHF I PUSHING AND PULLING TOOL
PART NO. 90224-001

Rev.7

MHF® I plug (2.0 mm Cable O.D.)

Recommended P/N	20767-001R-20
PART No.	
	20767-001R-20

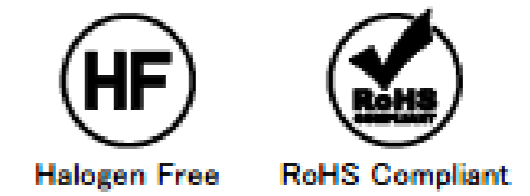
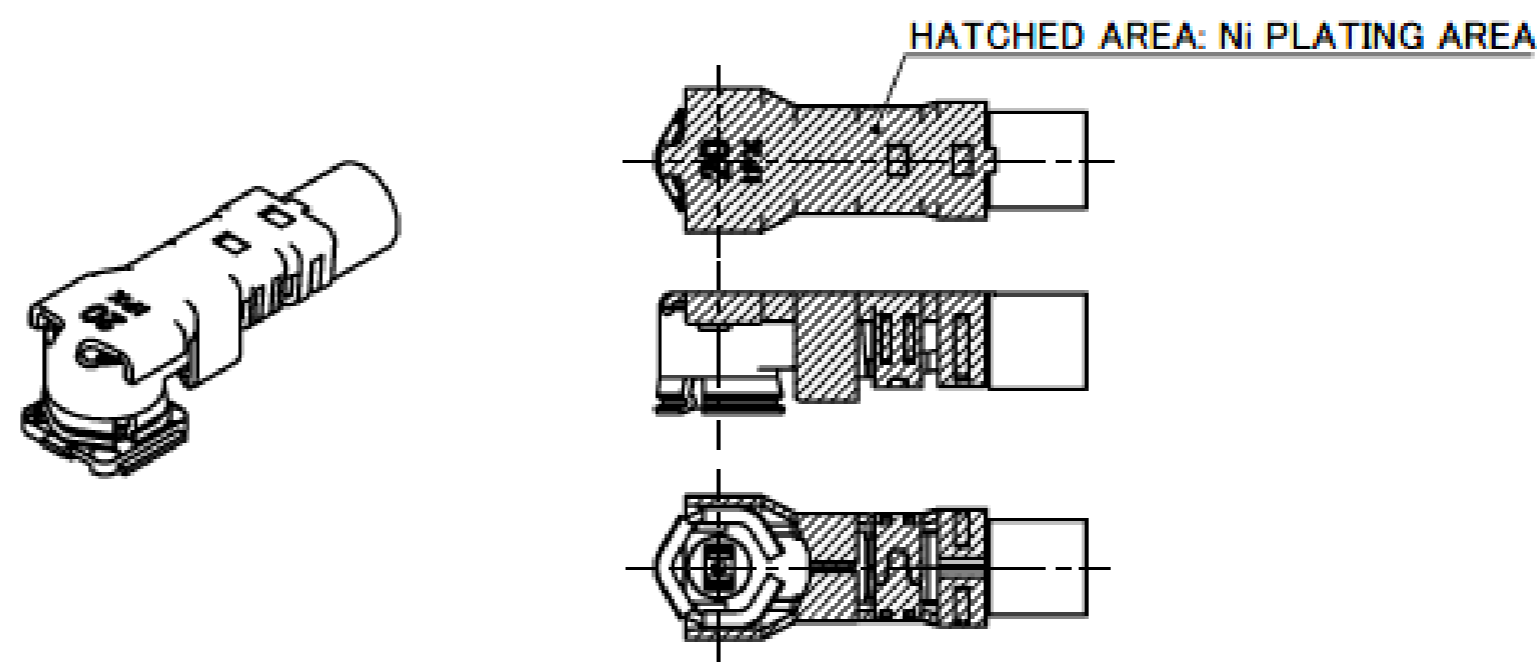
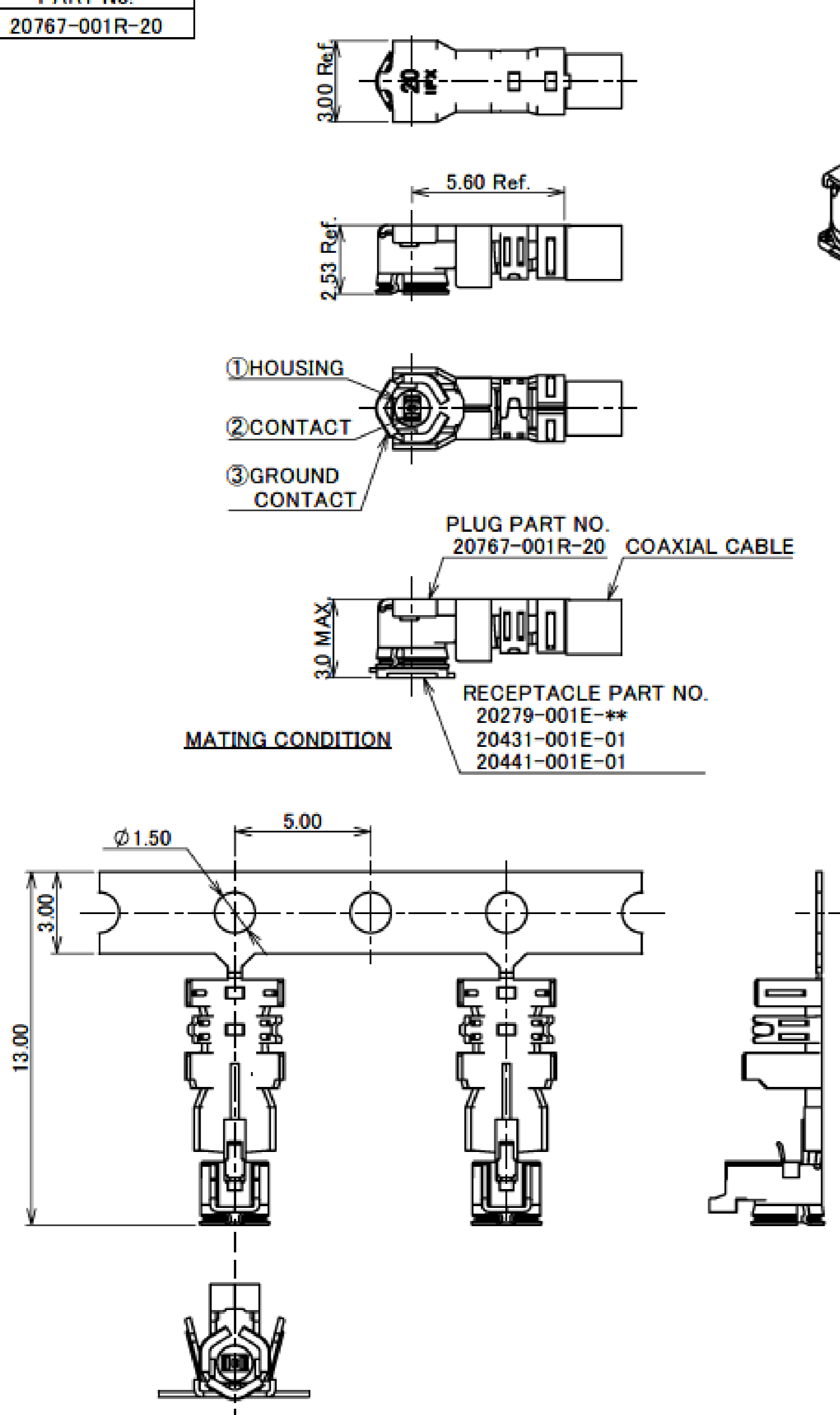

- NOTES
- APPLICABLE CONNECTOR:
20279-001E-**, 20431-001E-01, 20441-001E-01
 - MATING AND UNMATING INSTRUCTION
 - MATING
MATE THE CONNECTOR VERTICALLY AS MUCH AS POSSIBLE, ADJUSTING THE MATING AXIS OF PLUG AND RECEPTACLE. DO NOT SLANT MATE.
 - UNMATING
 - IN CASE OF UNMATING BY PULLING TOOL (PART NO. 90885-0001)
USE THE PULLING TOOL AS THE FOLLOWING DRAWING, AND PLEASE PULL PLUG TO VERTICAL DIRECTION AS DIRECTLY AS POSSIBLE.
 - IN CASE OF UNMATING DIRECTLY BY HAND
CATCH THE CATCHING AREA OF PLUG, AND PULL PLUG TO VERTICAL DIRECTION AS DIRECTLY AS POSSIBLE.

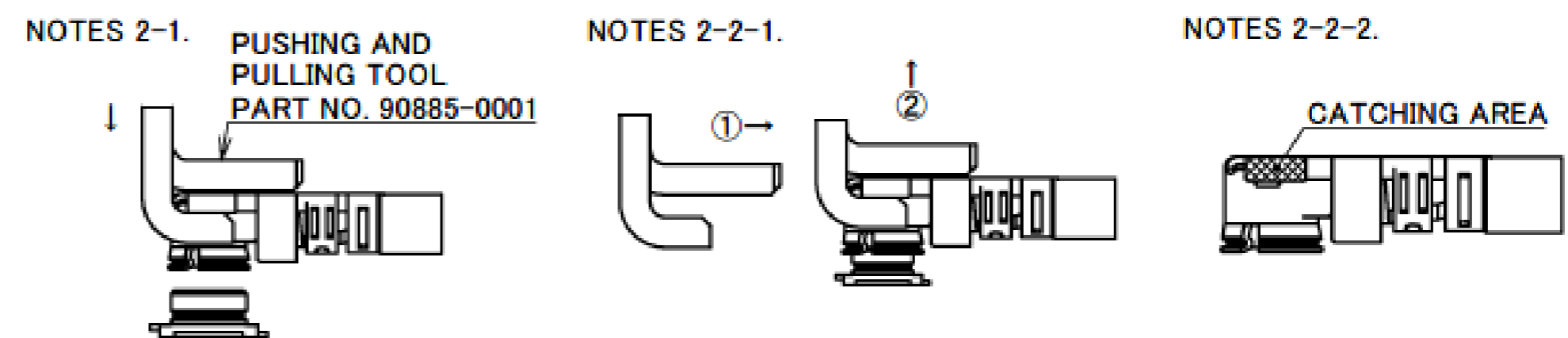

NO.	DESCRIPTION	MATERIAL	FINISH, REMARKS
3	GROUND CONTACT	PHOSPHOR BRONZE	ALL OVER Ni 1.00 μm MIN. CONTACT PART Au 0.05 μm MIN.
2	CONTACT	PHOSPHOR BRONZE	ALL OVER Ni 1.00 μm MIN. CONTACT PART Au 0.10 μm MIN.
1	HOUSING	PBT	UL94V-0, BLACK

Rev.5

MHF® I plug (2.0 mm Cable O.D.)

PART NO.	20767-001R-20		
APPLICABLE CABLE NOMINAL DIMENSION			
BRAIDED SHIELD OF OUTER CONDUCTOR	SINGLE		
PART NO. OF SEMI AUTO TERMINATION MACHINE	90876-020		
CRIMP HEIGHT	CH-1 i-Fit® PART	CH-2 SHIELD PART	CH-3 JACKET PART
	 2.28~2.36	 1.81~1.87	 1.95~2.01

Rev.5

ITEMS	SPECIFICATION	
RECOMMENDED APPLICABLE CONNECTOR PART No.	20279-001E-**	20441-001E-01
RATING VOLTAGE	60 V AC (R.M.S)	
RATING FREQUENCY	DC~9GHz	
OPERATING TEMPERATURE	233~363 K (-40°C~+90°C)	
VSWR (MATED WITH SMA ADAPTER PART No.90193-001)	1.30 MAX. AT 0.1~3 GHz, 1.50 MAX. AT 3~6 GHz, 1.60 MAX. AT 6~9 GHz	
MAIN CONTACT RESISTANCE	INITIAL: 20 mohm MAX. / AFTER TEST: ∇ R 20 mohm MAX.	
GROUND CONTACT RESISTANCE	INITIAL: 20 mohm MAX. / AFTER TEST: ∇ R 100 mohm MAX.	
INSULATION RESISTANCE	INITIAL: 500 Mohm MIN. / AFTER TEST: 100 Mohm MIN.	
DIELECTRIC WITHSTANDING VOLTAGE	200 V AC, 1 MINUTE	
DURABILITY	30 CYCLES	
UNMATING FORCE (INITIAL / AFTER TEST)	5 N MIN. / 3 N MIN.	
CRIMP STRENGTH	15 N MIN.	
PRODUCT SPECIFICATION	PRS-2490	
TEST REPORT	TR-18041	
PACKING STANDARD	PST-16007	
INSTRUCTION MANUAL	HIM-17017	
APPEARANCE CRITERIA No.	QLS-A***	

Accessories for MHF[®] I plug (2.0 mm Cable O.D.)

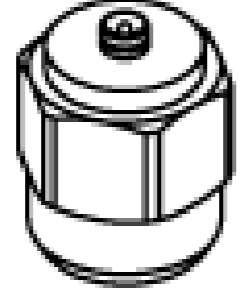

MHF I/II SMA ADAPTOR
PART NO. 90193-001



MHF I/II PLUG INSPECTION CONNECTOR
PART NO. 90194-001

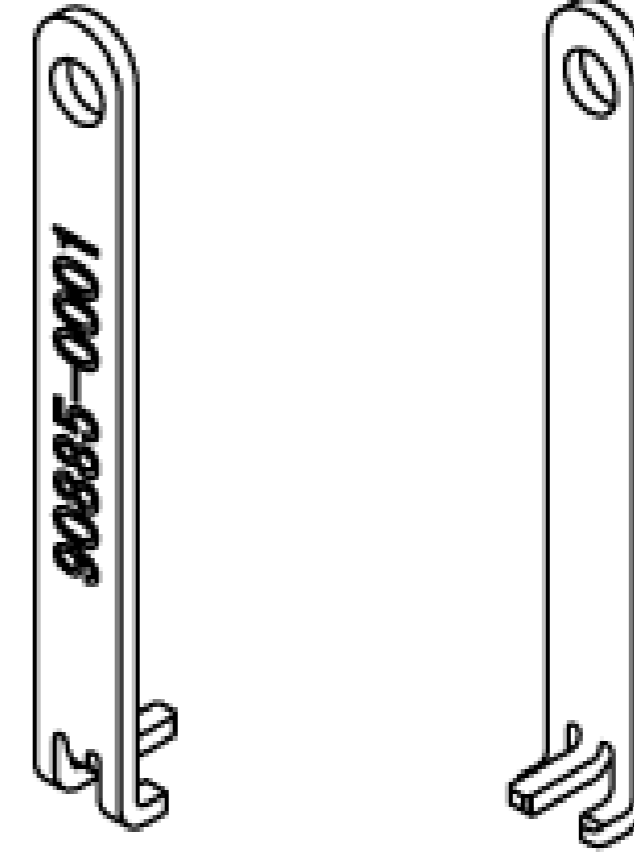

FRONT SIDE BACK SIDE
MHF I PLUG (2.00) PUSHING AND PULLING TOOL
PART NO. 90885-0001

Rev.5

MHF[®] I Receptacle (3pads)

Recommended P/N	20279-001E-03	
PART NO.	PACKING REEL	QUANTITY IN 1 REEL
20279-001E-01	PLASTIC REEL	2,500
	CORRUGATED PAPER REEL	2,500
20279-001E-03	PLASTIC REEL	5,000
20279-001E-05	PLASTIC REEL	10,000

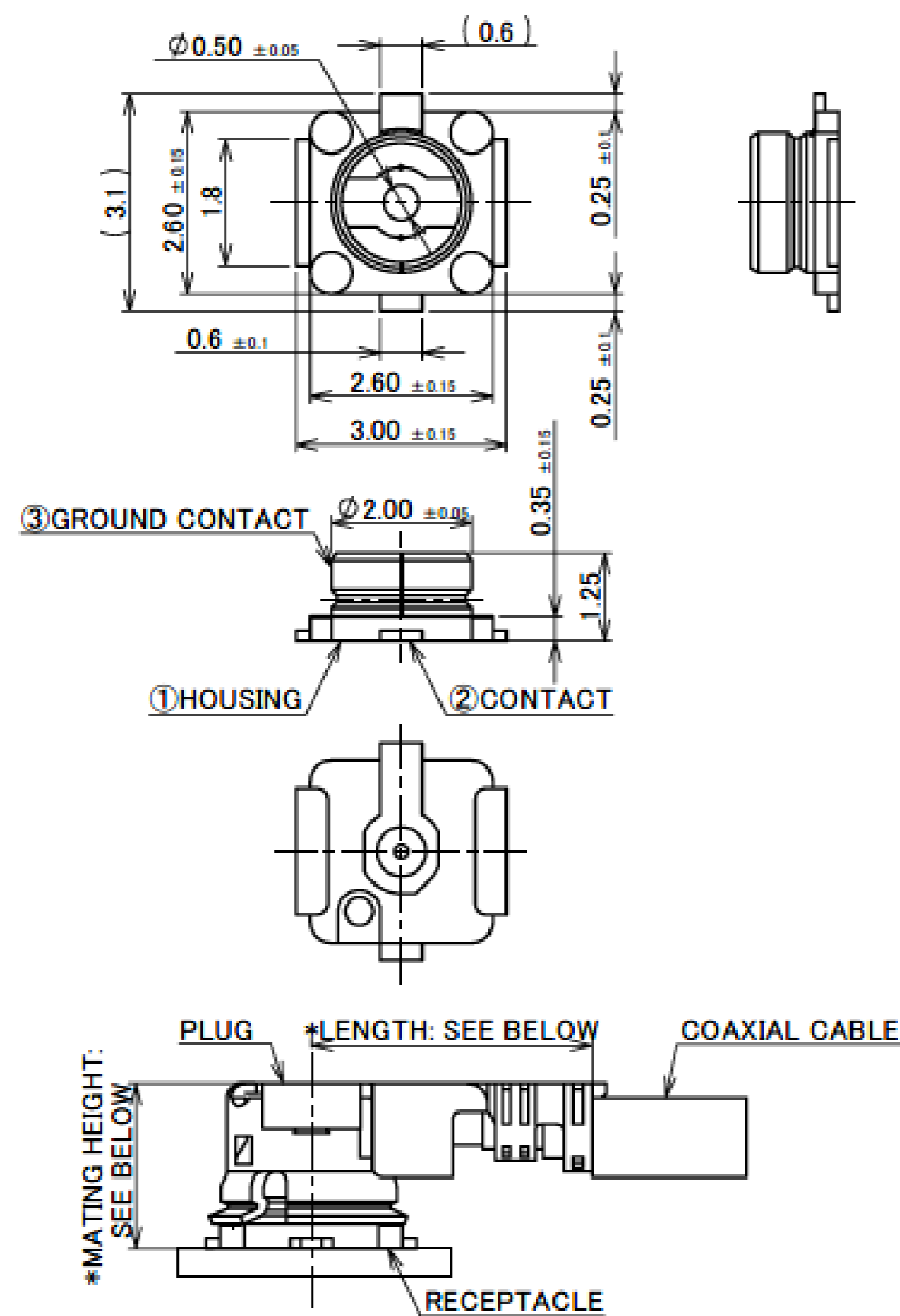
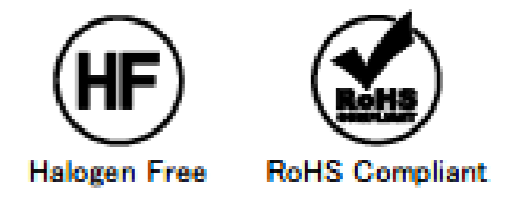

- NOTES
1. APPLICABLE CONNECTOR PART NO.
MHF I PLUG
20278-11*R-**-
20351-***R-37
20631-***R-**-
20670-001R-**-
20767-001R-20
MHF II PLUG
20311-011R-**-
20686-001R-08
 2. COPLANARITY: 0.1mm MAX.
 3. THIS IS "Pb-FREE" CONNECTOR.

NO.	DISCRIPTION	MATERIAL	FINISH, REMARKS
3	GROUND CONTACT	PHOSPHOR BRONZE	ALL OVER Ni 1.00 μ m MIN. CONTACT PART Au 0.05 μ m MIN. SOLDERING PART Au 0.05 μ m MIN.
2	CONTACT	BRASS	ALL OVER Ni 1.00 μ m MIN. CONTACT PART Au 0.10 μ m MIN. SOLDERING PART Au 0.03 μ m MIN.
1	HOUSING	LCP	UL94V-0, WHITE

- *LENGTH: 4.0 \pm 0.4 AT PLUG PART NO. 20670-001R-08, 20670-001R-13, 20670-001R-32
4.7 \pm 0.4 AT PLUG PART NO. 20670-001R-18, 20670-001R-37
5.6 AT PLUG PART NO. 20767-001R-20 (REFERENCE DIMENSION)
3.8 \pm 0.3 AT PLUG PART NO. 20686-001R-08, 20311-011R-**-
- *MATING HEIGHT: 2.5 MAX. AT PLUG PART NO. 20670-001R-**-
(2.9 MAX. AT MHF I LK LOCKED CONDITION)
3.0 MAX. AT PLUG PART NO. 20767-001R-20
2.0 \pm 0.1 AT PLUG PART NO. 20686-001R-08, 20311-011R-**-

MATING CONDITION

Rev.32

MHF® I Receptacle (3pads)

Recommended P/N	20279-001E-03	
PART NO.	PACKING REEL	QUANTITY IN 1 REEL
20279-001E-06	PLASTIC REEL	10,000

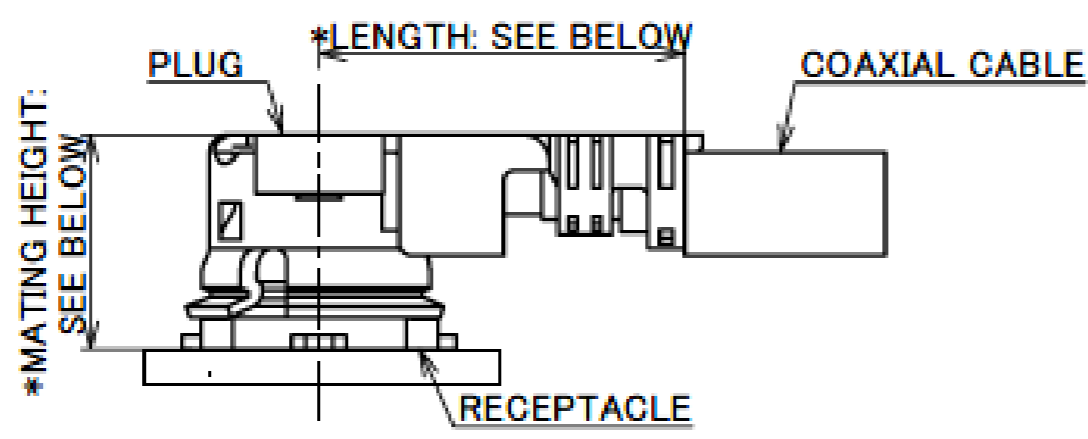
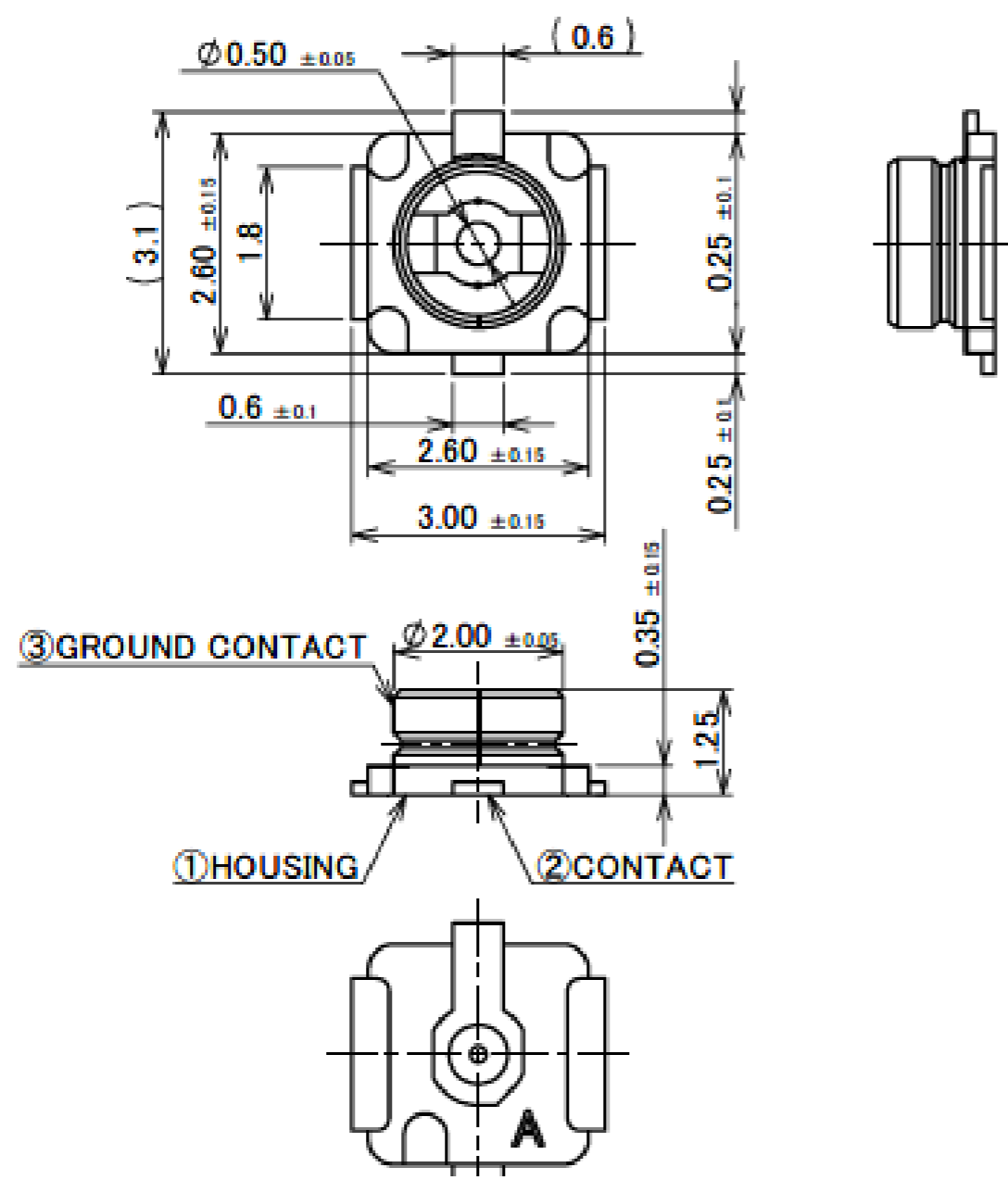
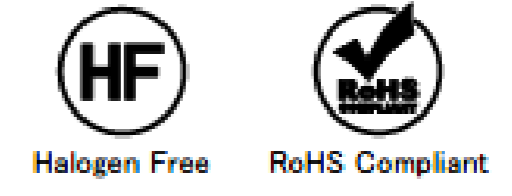

- *LENGTH: 4.0 ± 0.4 AT PLUG PART NO. 20670-001R-08, 20670-001R-13, 20670-001R-32
- 4.7 ± 0.4 AT PLUG PART NO. 20670-001R-18, 20670-001R-37
- 5.6 AT PLUG PART NO. 20767-001R-20 (REFERENCE DIMENSION)
- 3.8 ± 0.3 AT PLUG PART NO. 20686-001R-08, 20311-011R-08
- *MATING HEIGHT: 2.5 MAX. AT PLUG PART NO. 20670-001R-08
- $(2.9$ MAX. AT MHF I LK LOCKED CONDITION)
- 3.0 MAX. AT PLUG PART NO. 20767-001R-20
- 2.0 ± 0.1 AT PLUG PART NO. 20686-001R-08, 20311-011R-08

MATING CONDITION

- NOTES
- APPLICABLE CONNECTOR PART NO.
MHF I PLUG
20278-11R-08
20351-001R-37
20631-001R-08
20670-001R-08
20767-001R-20
MHF II PLUG
20311-011R-08
20686-001R-08
 - COPLANARITY: 0.1 mm MAX.
 - THIS IS "Pb-FREE" CONNECTOR.

NO.	DISCRIPTION	MATERIAL	FINISH . REMARKS
3	GROUND CONTACT	PHOSPHOR BRONZE	ALL OVER Ni $1.00 \mu\text{m}$ MIN. CONTACT PART Au $0.05 \mu\text{m}$ MIN. SOLDERING PART Au $0.05 \mu\text{m}$ MIN.
2	CONTACT	BRASS	ALL OVER Ni $1.00 \mu\text{m}$ MIN. CONTACT PART Au $0.10 \mu\text{m}$ MIN. SOLDERING PART Au $0.03 \mu\text{m}$ MIN.
1	HOUSING	LCP	UL94V-0, WHITE

Rev.32

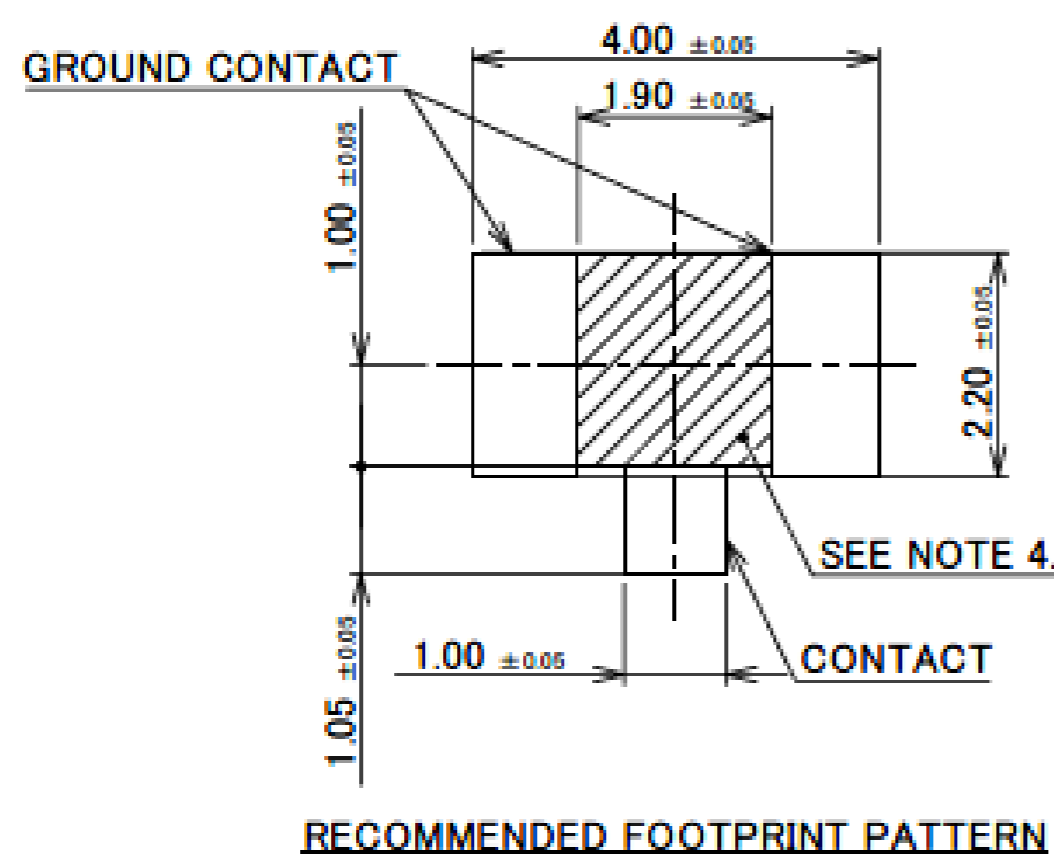

RECOMMENDED FOOTPRINT PATTERN

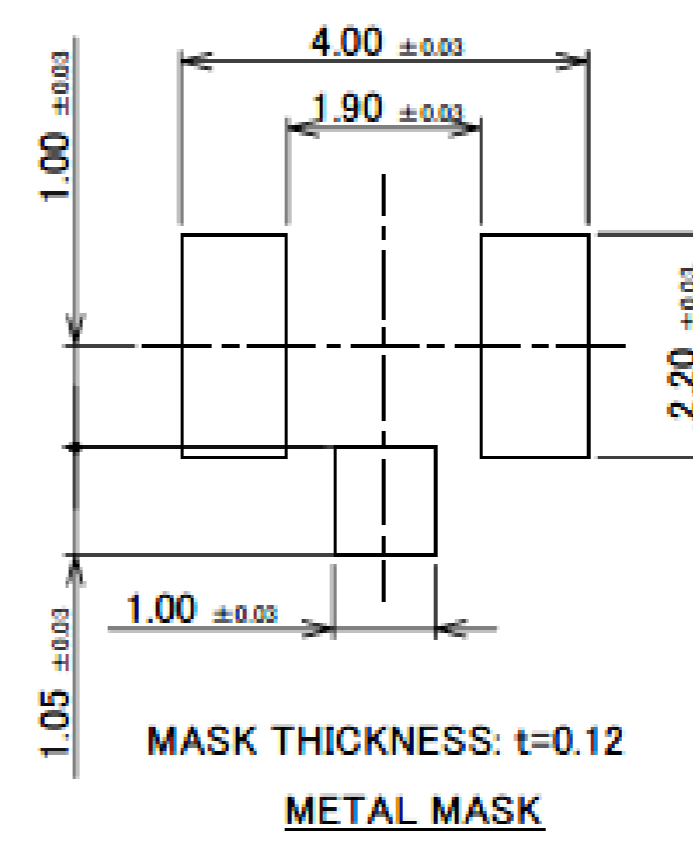

METAL MASK

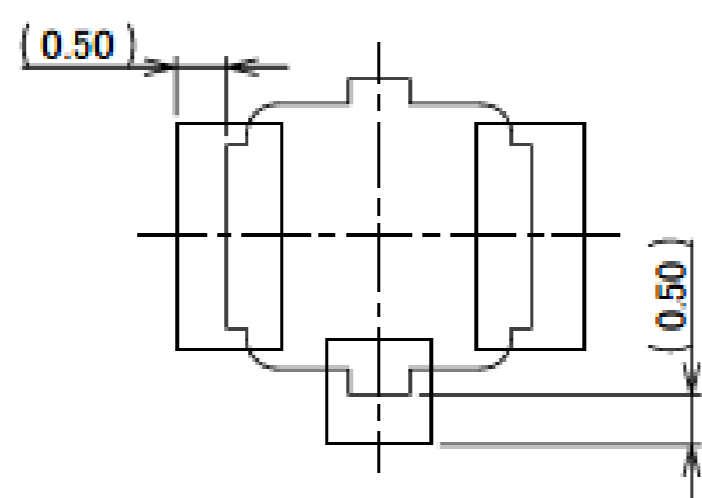

CONNECTOR ON RECOMMENDED FOOTPRINT PATTERN

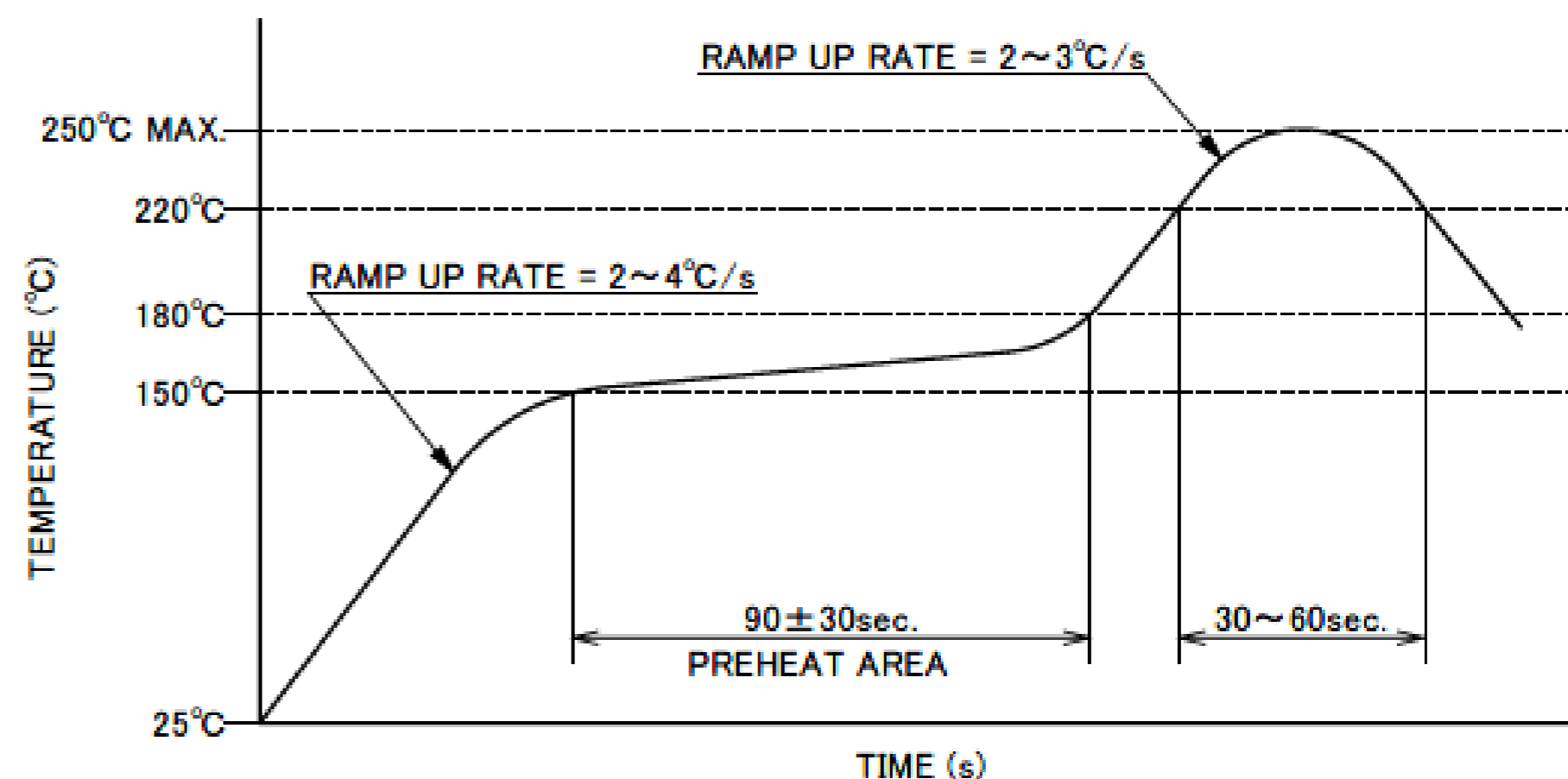

REFLOW TEMPERATURE PROFILE
SENJU METAL INDUSTRY CO., LTD. : M705-SHF(Sn96.5 Ag3.0 Cu0.5)

- NOTES.
- NO GROUND, SIGNAL, AND RESIST IN THIS AREA.

Rev.32

MHF® I Receptacle (3pads)

COMPONENT PLACEMENT PROHIBITED AREA FOR MHF I/II RECEPTACLE MATED WITH MHF I LK HARNESS REQUIRED AREA FOR RECOMMENDED JIG TO OPERATE

SINGLE CONNECTOR LAYOUT

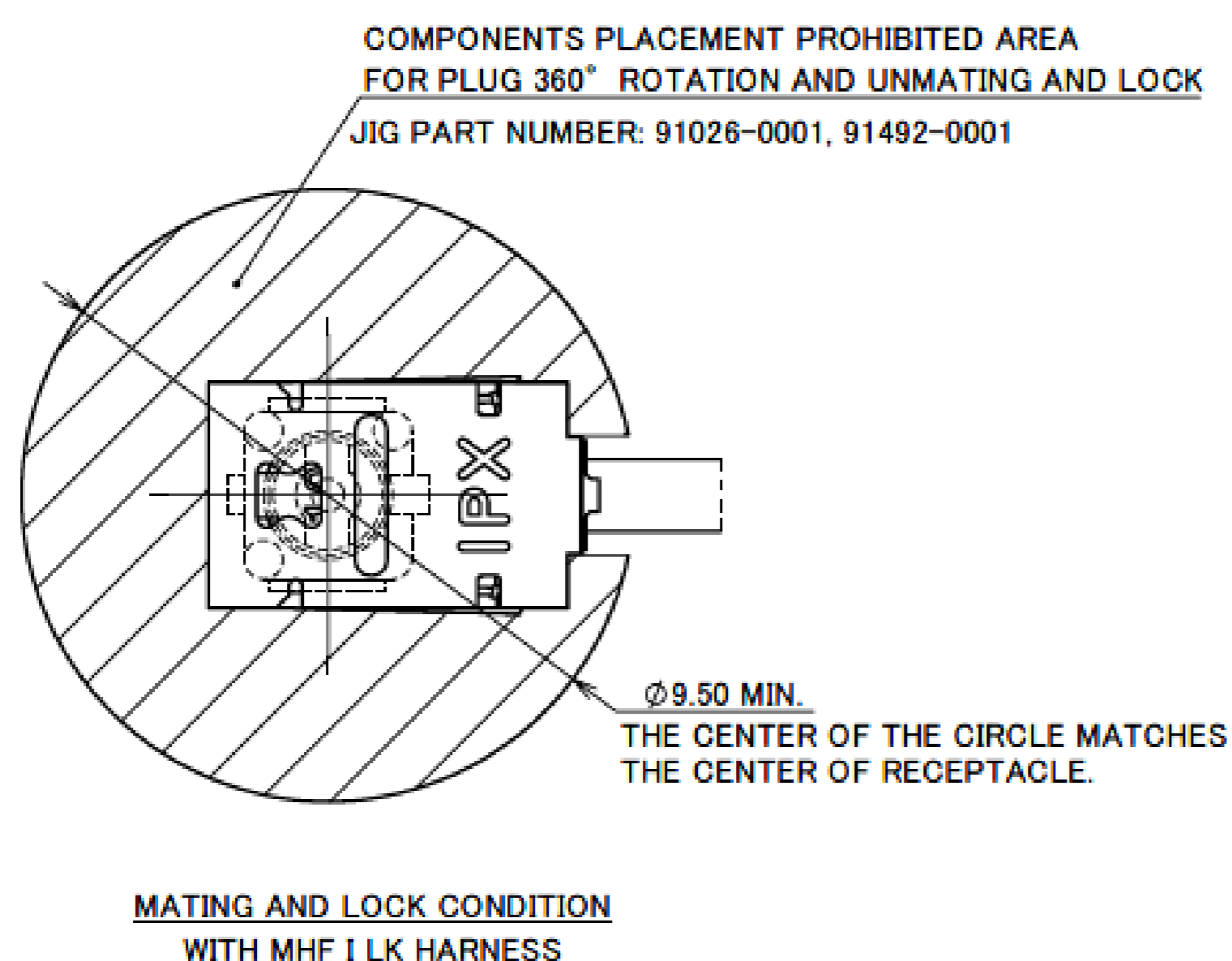

MULTIPLE CONNECTORS LAYOUT

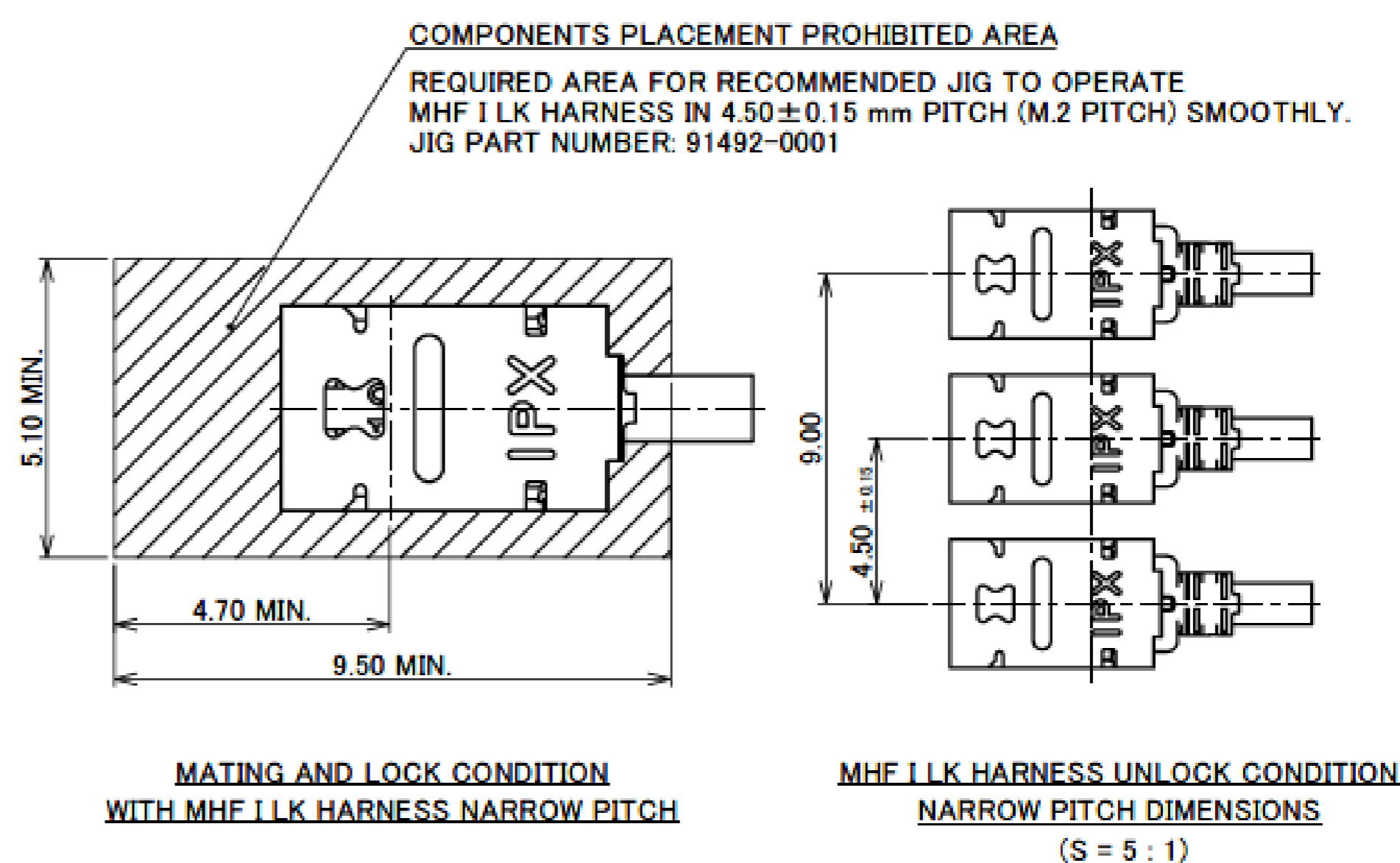

Rev.32

ITEMS	SPECIFICATION				
	20278-001R-*** (MHF I PLUG 1.80, 1.32, 1.13, 0.81)	20351-001R-*** (MHF I PLUG 1.37)	20670-001R-*** (MHF I PLUG Ni TOP 1.80, 1.37, 1.32, 1.13, 0.81)	20767-001R-20 (MHF I PLUG 2.00)	20686-001R-08 (MHF II PLUG Ni TOP 0.81)
RECOMMENDED APPLICABLE CONNECTOR PART NO.					
RATING VOLTAGE	60 V AC (R.M.S)				
RATING FREQUENCY	DC~9GHz				
OPERATING TEMPERATURE	233~363K (-40°C~+90°C)				
VSWR (MATED WITH SMA ADAPTER PART No.90193-002)	RECEPTACLE: 1.30 MAX. AT 0.1~3 GHz, 1.40 MAX. AT 3~6 GHz, 1.80 MAX. AT 6~9 GHz				
MAIN CONTACT RESISTANCE	INITIAL : 20 mohm MAX. AFTER TEST : 25 mohm MAX.		INITIAL : 20 mohm MAX. AFTER TEST : \angle R 20 mohm MAX.		
GROUND CONTACT RESISTANCE	INITIAL : 10 mohm MAX. AFTER TEST : 15 mohm MAX.		INITIAL : 20 mohm MAX. AFTER TEST : \angle R 100 mohm MAX.		
INSULATION RESISTANCE	INITIAL: 500 Mohm MIN. / AFTER TEST: 100 Mohm MIN.				
DIELECTRIC WITHSTANDING VOLTAGE	200 V AC, 1 MINUTE				
DURABILITY	30 CYCLES				
UNMATING FORCE (INITIAL / AFTER TEST)	INITIAL: 5 N MIN. AFTER TEST: 3 N MIN.				INITIAL: 4 N MIN. AFTER TEST: 2 N MIN.
PRODUCT SPECIFICATION	PRS-1676	PRS-1726	PRS-2105	PRS-2490	PRS-2106
TEST REPORT	TR-12044	TR-12096	TR-15059	TR-18041	TR-15060
PACKING STANDARD	20279-001E-01: 300-232 (CORRUGATED PAPER REEL) PST-12002 (ANTI-STATIC PLASTIC REEL) 20279-001E-03: 300-850 20279-001E-05: PST-13040 20279-001E-06: PST-13040				
INSTRUCTION MANUAL	HIM-10002		HIM-17017	HIM-12010	
APPEARANCE CRITERIA No.	QLS-A***				

※UNLESS OTHERWISE SPECIFIED, 20279-001E-01 WILL BE DELIVERED IN CORRUGATED PAPER REELS.
CONTACT YOUR I-PEX SALES IF YOU WISH FOR PLASTIC REELS.

MHF® I Receptacle (4pads/Black color HSG)

Recommended P/N	20441-001E-01
PART No.	20441-001E-01

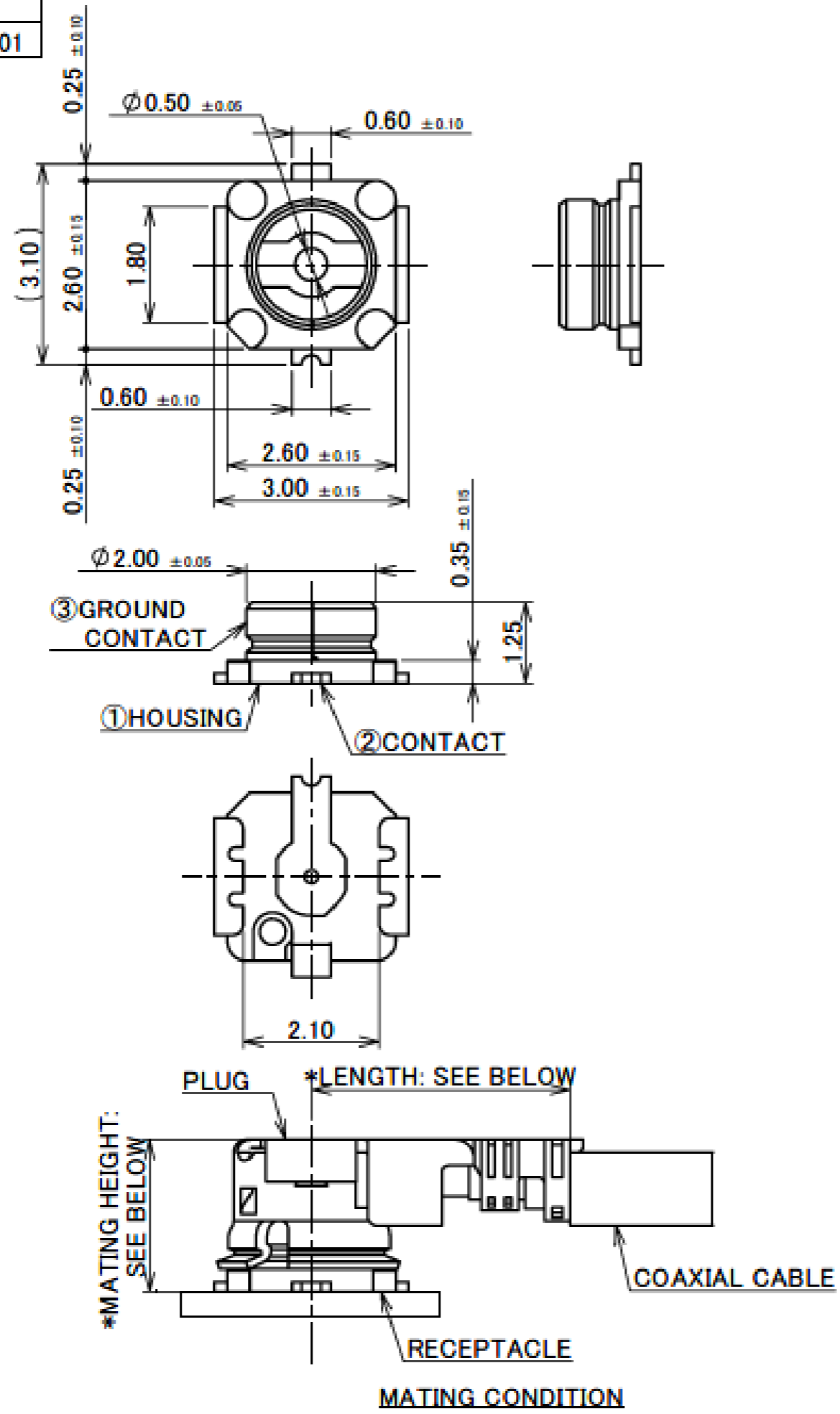
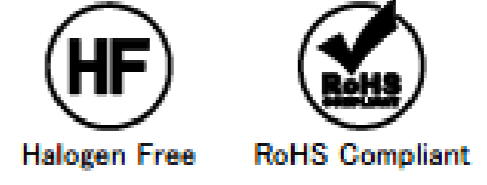

- NOTES:
 1. APPLICABLE CONNECTOR PART NUMBER:
 MHF I PLUG
 20278-112R-**-**
 20351-1**R-37
 20670-001R-**-**
 20767-001R-20
 MHF II PLUG
 20311-011R-**-**
 20686-001R-08
 2. COPLANARITY: 0.1mm MAX.
 3. THIS IS "Pb-FREE" CONNECTOR.

NO.	DISCRPTION	MATERIAL	FINISH, REMARKS
3	GROUND CONTACT	PHOSPHOR BRONZE	ALL OVER Ni 1.00 μm MIN. CONTACT PART Au 0.03 μm MIN. SOLDERING PART Au 0.03 μm MIN.
2	CONTACT	BRASS	ALL OVER Ni 1.00 μm MIN. CONTACT PART Au 0.10 μm MIN. SOLDERING PART Au 0.03 μm MIN.
1	HOUSING	LCP	UL94V-0, BLACK

- *LENGTH: 4.0±0.4 AT PLUG PART NO. 20670-001R-08, 20670-001R-13, 20670-001R-32
 4.7±0.4 AT PLUG PART NO. 20670-001R-18, 20670-001R-37
 5.6 AT PLUG PART NO. 20767-001R-20 (REFERENCE DIMENSION)
 3.8±0.3 AT PLUG PART NO. 20686-001R-08, 20311-011R-**-**
 *MATING HEIGHT: 2.5 MAX. AT PLUG PART NO. 20670-001R-**-**
 (2.9 MAX. AT MHF I LK LOCKED CONDITION)
 3.0 MAX. AT PLUG PART NO. 20767-001R-20
 2.0±0.1 AT PLUG PART NO. 20686-001R-08, 20311-011R-**-**

Rev.7

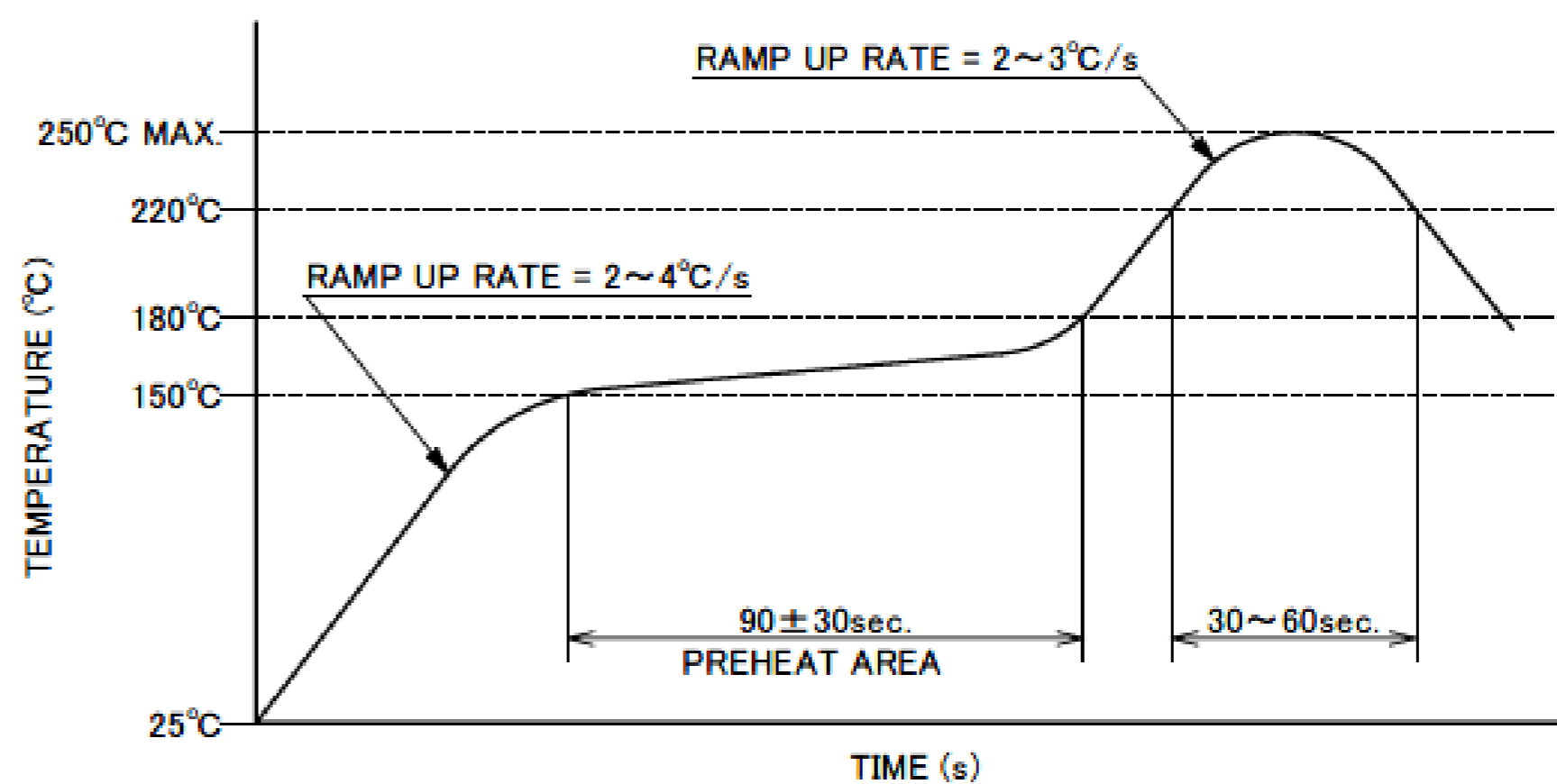
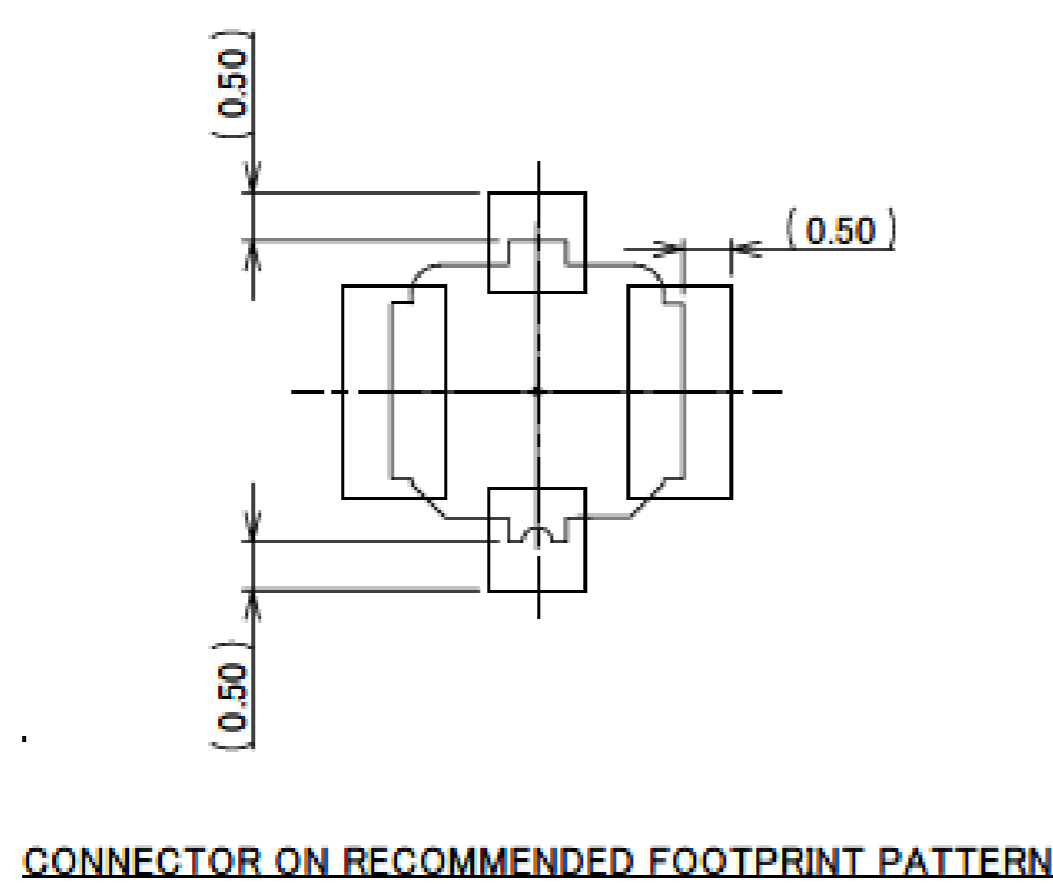
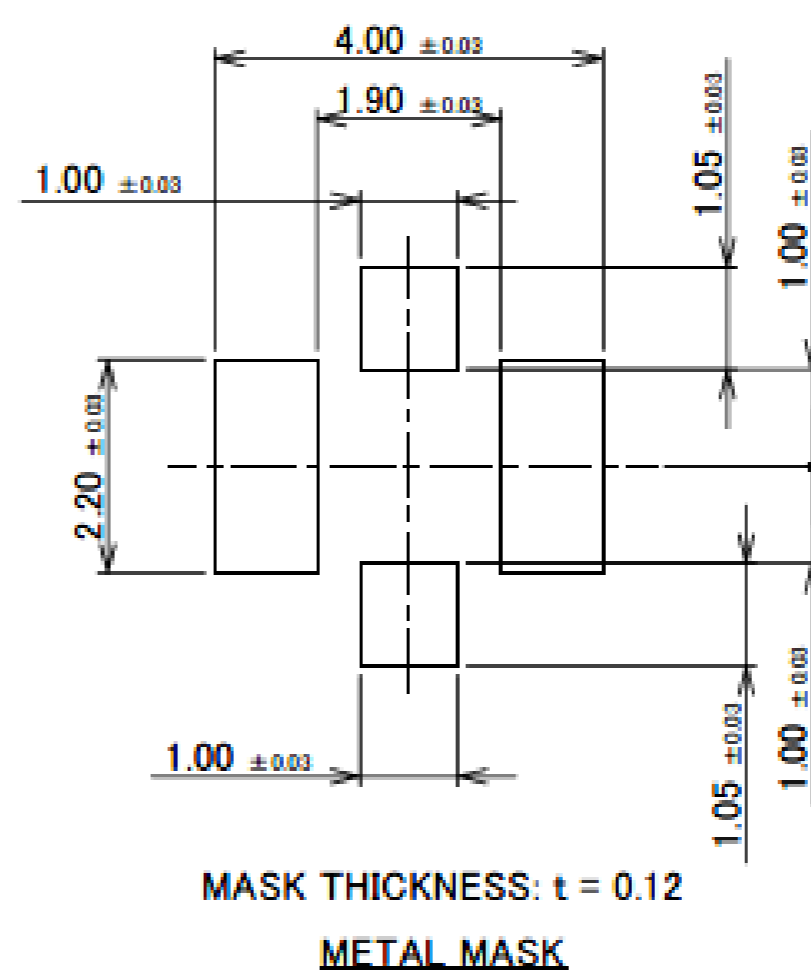
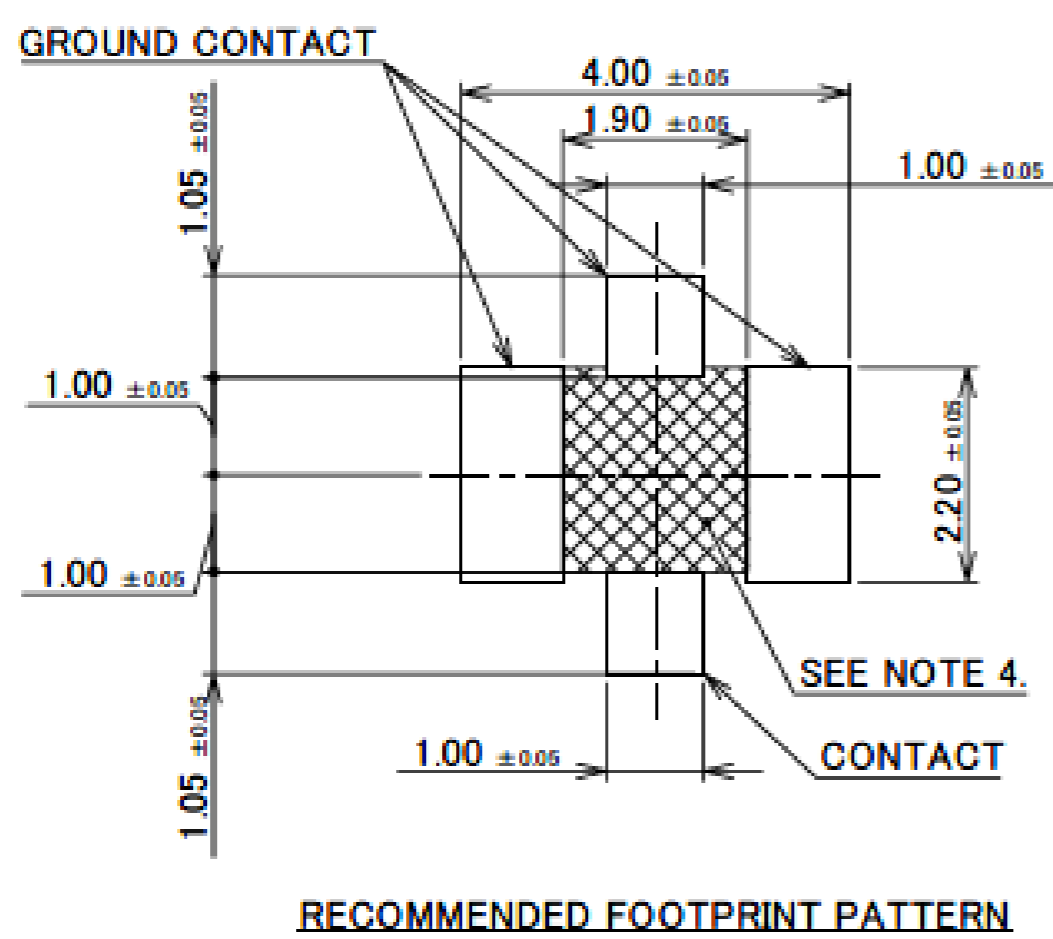

REFLOW TEMPERATURE PROFILE
 SENJU METAL INDUSTRY CO., LTD. : M705-SHF(Sn96.5 Ag3.0 Cu0.5)

NOTE
 4. NO GROUND, SIGNAL, RESIST IN THIS AREA.

Rev.7

MHF® I Receptacle (4pads/Black color HSG)

COMPONENT PLACEMENT PROHIBITED AREA FOR MHF I/II RECEPTACLE MATED WITH MHF I LK HARNESS REQUIRED AREA FOR RECOMMENDED JIG TO OPERATE

SINGLE CONNECTOR LAYOUT

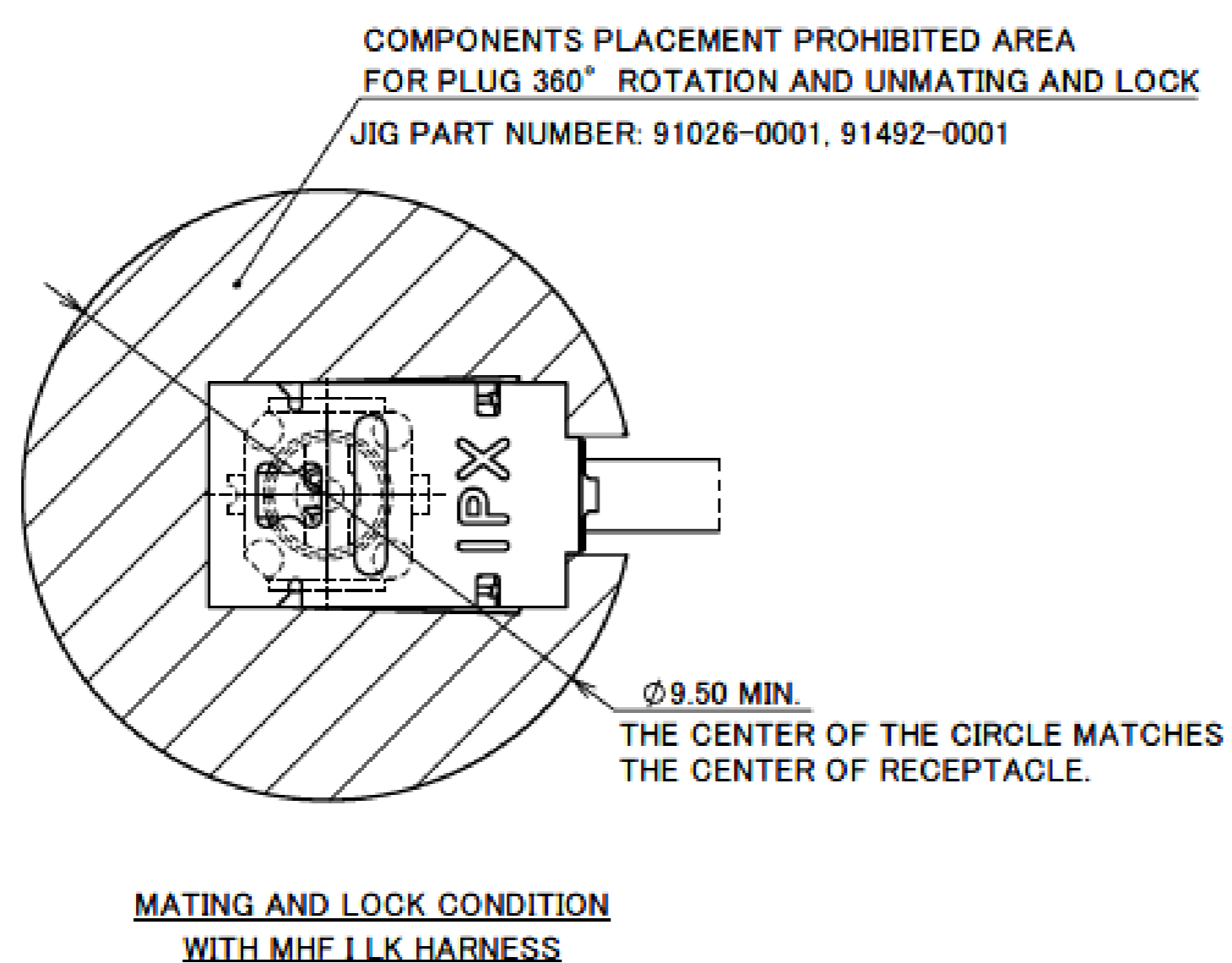

MULTIPLE CONNECTORS LAYOUT

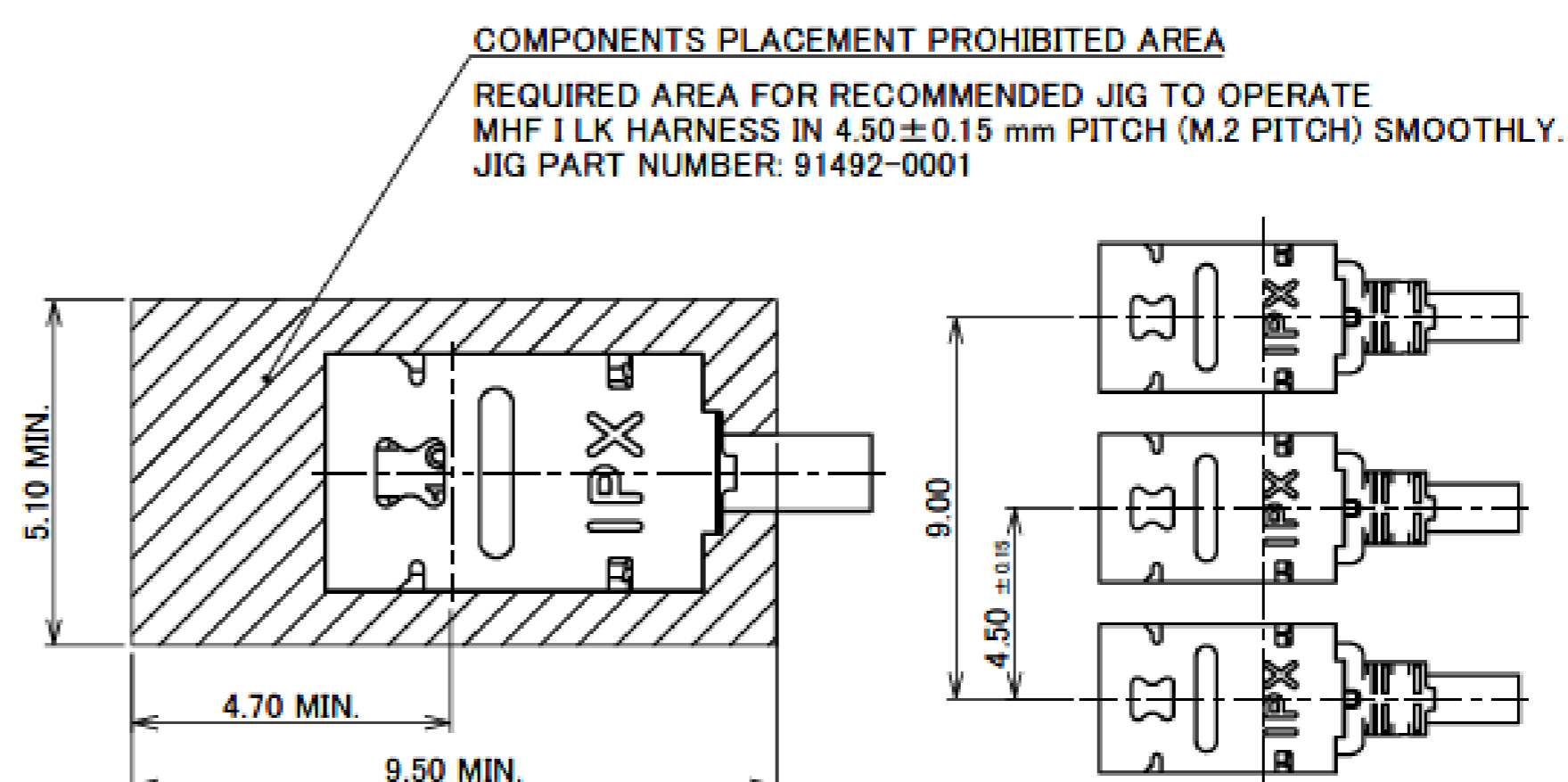

Rev.7

ITEMS	SPECIFICATION				
RECOMMENDED APPLICABLE CONNECTOR PART NO.	20278-001R-** (MHF I PLUG 1.80, 1.32, 1.13, 0.81)	20351-001R-** (MHF I PLUG 1.37)	20670-001R-** (MHF I PLUG Ni TOP 1.80, 1.37, 1.32, 1.13, 0.81)	20767-001R-20 (MHF I PLUG 2.00)	20686-001R-08 (MHF II PLUG Ni TOP 0.81)
RATING VOLTAGE	60 V AC (R.M.S)				
RATING FREQUENCY	DC~9GHz				
OPERATING TEMPERATURE	233~363K (-40°C~+90°C)				
VSWR (MATED WITH SMA ADAPTER PART No.90193-002)	RECEPTACLE: 1.30 MAX. AT 0.1~3 GHz, 1.40 MAX. AT 3~6 GHz, 1.80 MAX. AT 6~9 GHz				
MAIN CONTACT RESISTANCE	INITIAL : 20 mohm MAX. AFTER TEST : 25 mohm MAX.		INITIAL : 20 mohm MAX. AFTER TEST : ΔR 20 mohm MAX.		
GROUND CONTACT RESISTANCE	INITIAL : 10 mohm MAX. AFTER TEST : 15 mohm MAX.		INITIAL : 20 mohm MAX. AFTER TEST : ΔR 100 mohm MAX.		
INSULATION RESISTANCE	INITIAL: 500 Mohm MIN. / AFTER TEST: 100 Mohm MIN.				
DIELECTRIC WITHSTANDING VOLTAGE	200 V AC, 1 MINUTE				
DURABILITY	30 CYCLES				
UNMATING FORCE (INITIAL / AFTER TEST)	INITIAL: 5 N MIN. AFTER TEST: 3 N MIN.				INITIAL: 4 N MIN. AFTER TEST: 2 N MIN.
PRODUCT SPECIFICATION	PRS-1676	PRS-1726	PRS-2105	PRS-2490	PRS-2106
TEST REPORT	TR-12044	TR-12096	TR-15059	TR-18041	TR-15060
PACKING STANDARD	300-596				
INSTRUCTION MANUAL	HIM-10002		HIM-17017		HIM-12010
APPEARANCE CRITERIA No.	QLS-A***				

Rev.7

MHF® I Receptacle (4pads/Natural color HSG)

Recommended P/N	20431-001E-01
PART No.	20431-001E-01

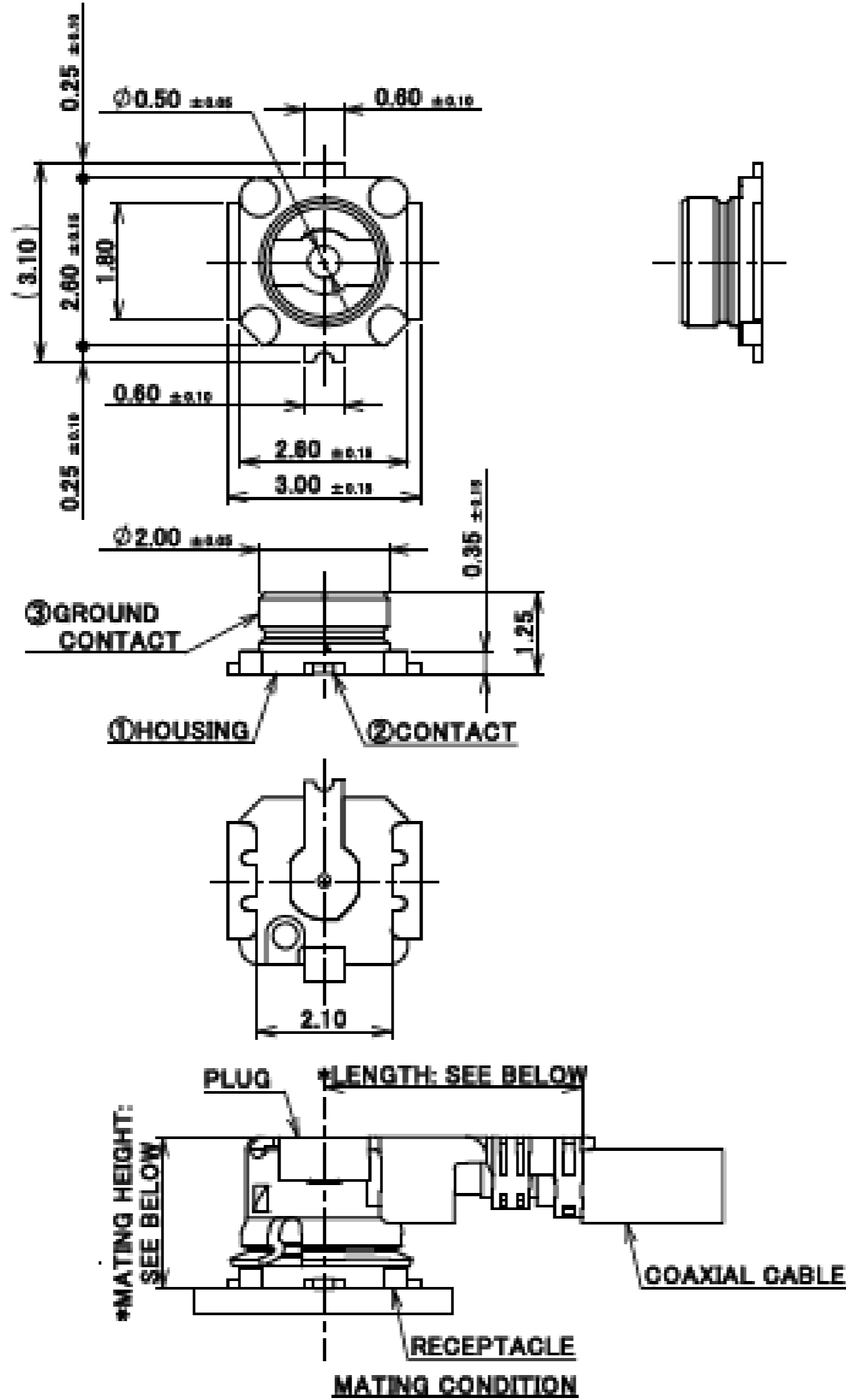
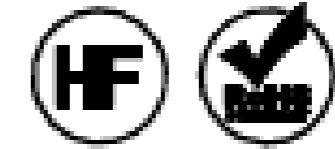

- NOTES.
- APPLICABLE CONNECTOR PART NUMBER:
MHF I PLUG
20278-112R-***
20351-1**R-37
20670-001R-***
20767-001R-20
MHF II PLUG
20311-011R-***
20686-001R-08
 - COPLANARITY: 0.1mm MAX.
 - THIS IS "Pb-FREE" CONNECTOR.

NO.	DISCRIPTION	MATERIAL	FINISH . REMARKS
3	GROUND CONTACT	PHOSPHOR BRONZE	ALL OVER NI 1.00 μm MIN. CONTACT PART Au 0.03 μm MIN. SOLDERING PART Au 0.03 μm MIN.
2	CONTACT	BRASS	ALL OVER NI 1.00 μm MIN. CONTACT PART Au 0.10 μm MIN. SOLDERING PART Au 0.03 μm MIN.
1	HOUSING	LCP	UL94V-0, WHITE

- *LENGTH: 4.0 ±0.4 AT PLUG PART NO. 20670-001R-08, 20670-001R-13, 20670-001R-32
4.7 ±0.4 AT PLUG PART NO. 20670-001R-18, 20670-001R-37
5.8 AT PLUG PART NO. 20767-001R-20 (REFERENCE DIMENSION)
3.8 ±0.3 AT PLUG PART NO. 20686-001R-08, 20311-011R-***
- *MATING HEIGHT: 2.5 MAX. AT PLUG PART NO. 20670-001R-***
3.0 MAX. AT PLUG PART NO. 20767-001R-20
2.0 ±0.1 AT PLUG PART NO. 20686-001R-08, 20311-011R-***

Rev.4

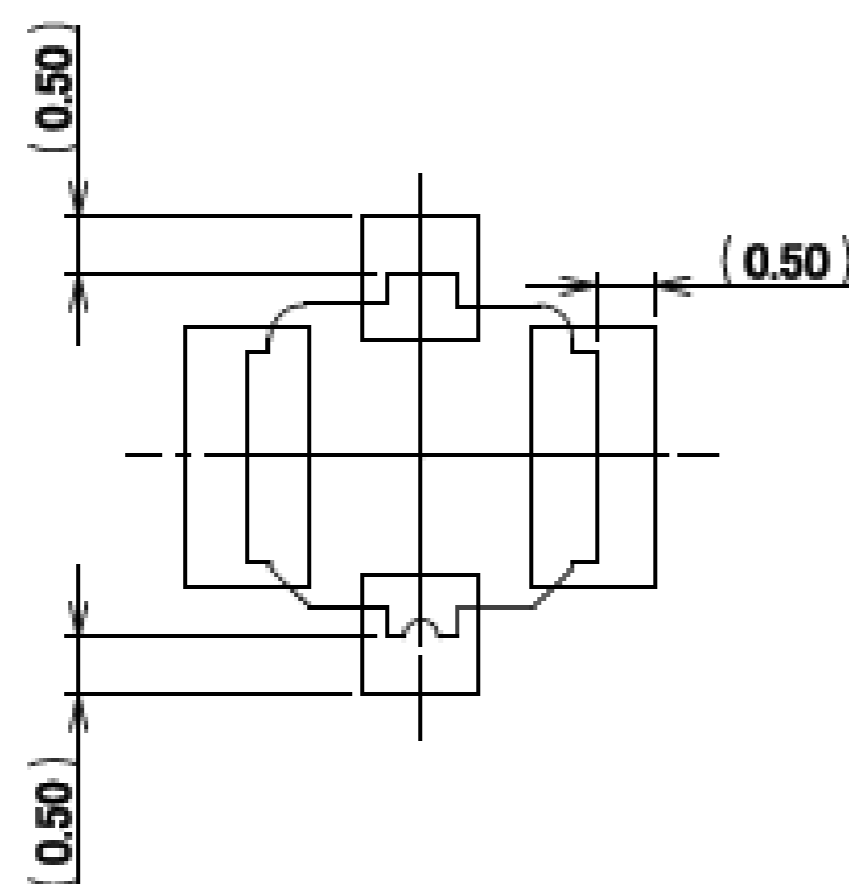
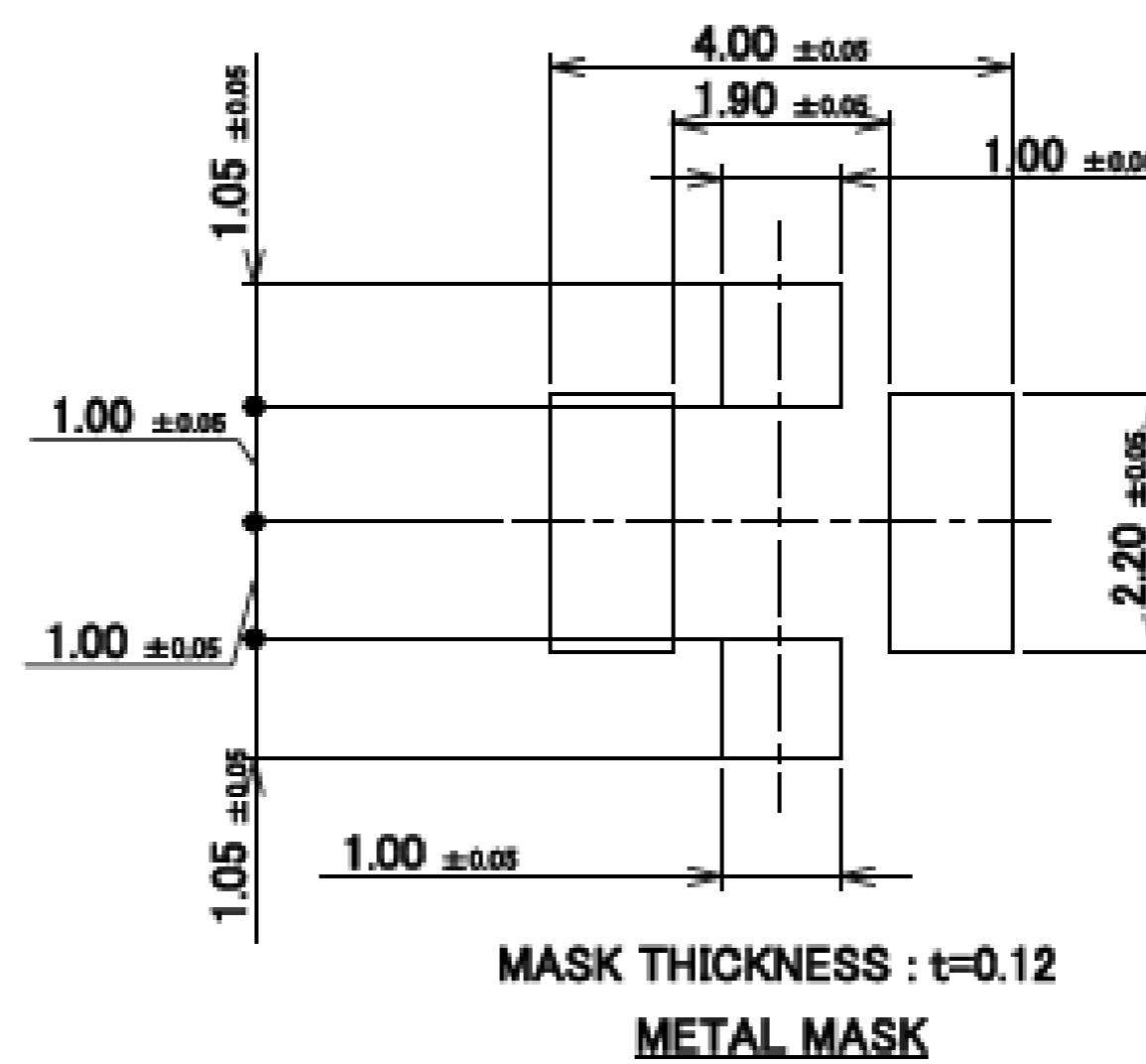
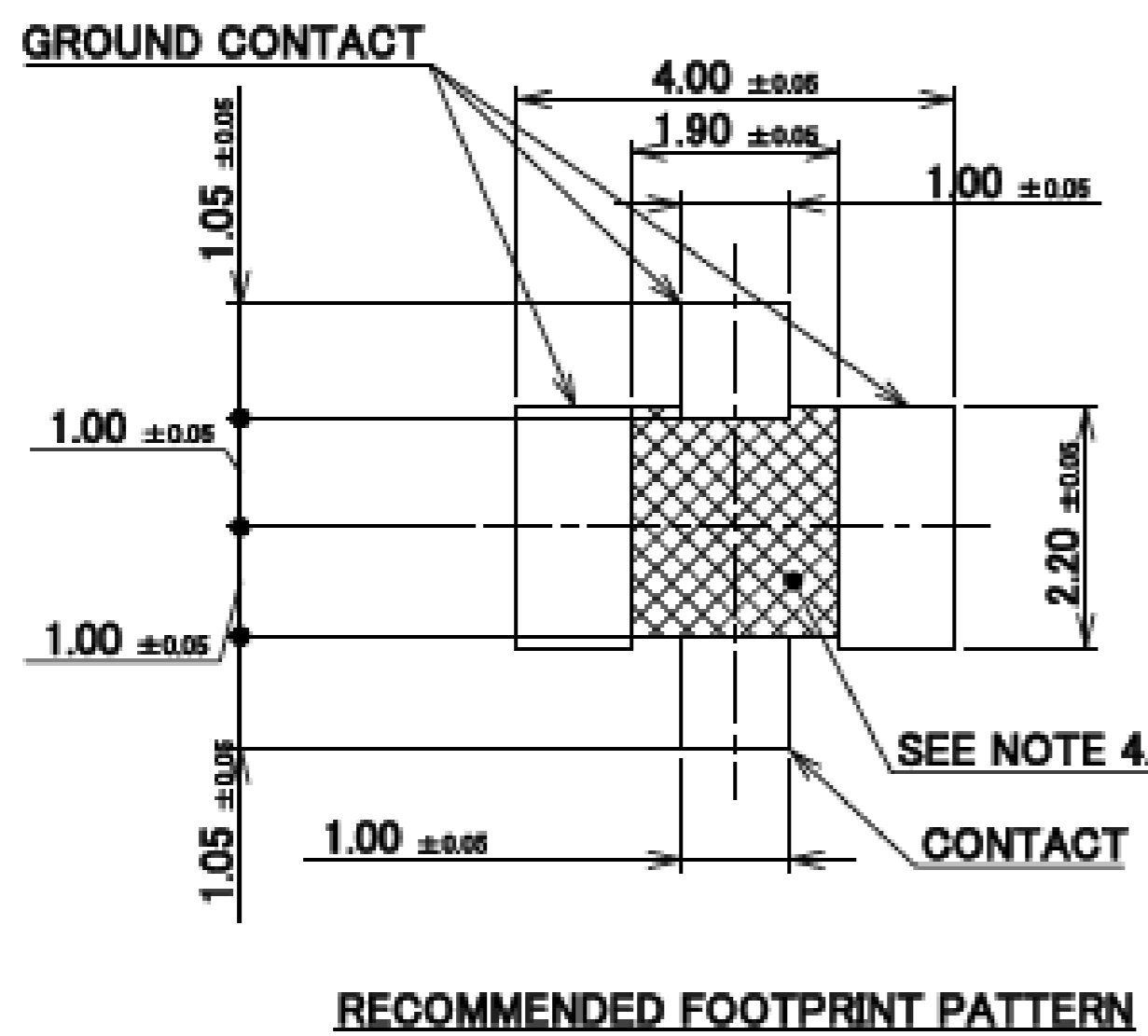

CONNECTOR ON RECOMMENDED FOOTPRINT PATTERN

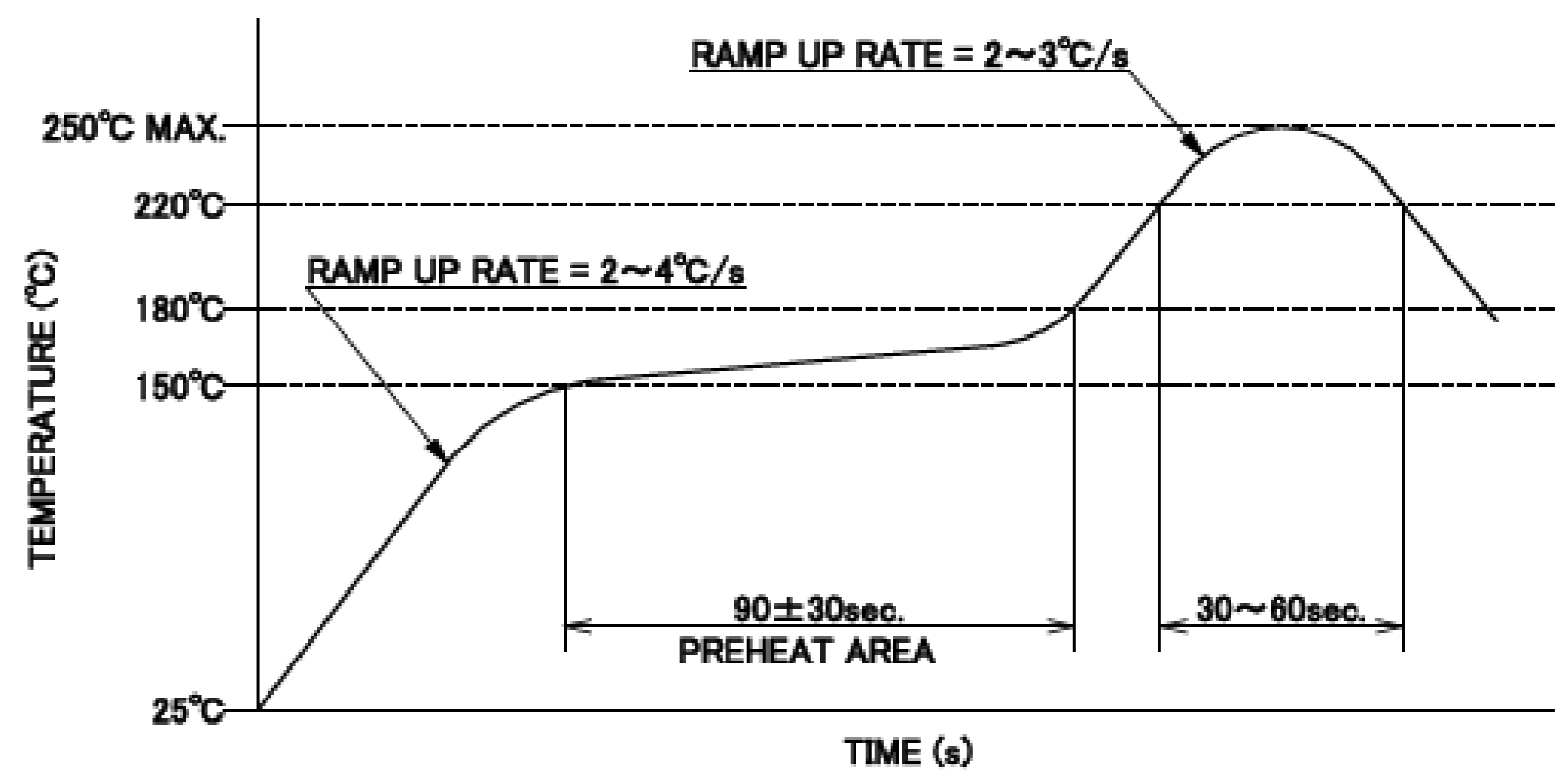

REFLOW TEMPERATURE PROFILE
SENJU METAL INDUSTRY CO., LTD. : M705-SHF(Sn96.5 Ag3.0 Cu0.5)

Rev.4

MHF® I Receptacle (4pads/Natural color HSG)

ITEMS	SPECIFICATION	
RECOMMENDED APPLICABLE CONNECTOR PART NO.	20670-001R-** (MHF I PLUG Ni TOP (1.80, 1.37, 1.32, 1.13, 0.81))	20686-001R-08 (MHF II PLUG Ni TOP (0.81))
RATING VOLTAGE	60 V AC (R.M.S)	
RATING FREQUENCY	DC~9GHz	
OPERATING TEMPERATURE	233~363K (-40°C~+90°C)	
VSWR	RECEPTACLE: 1.3 MAX AT 0.1~3 GHz, 1.4 MAX AT 3~6 GHz, 1.8 MAX. AT 6~9 GHz	
MAIN CONTACT RESISTANCE	INITIAL: 20 mohm MAX. / AFTER TEST: Δ R 20 mohm MAX.	
GROUND CONTACT RESISTANCE	INITIAL: 20 mohm MAX. / AFTER TEST: Δ R 100 mohm MAX.	
INSULATION RESISTANCE	INITIAL: 500 Mohm MIN. / AFTER TEST: 100 Mohm MIN.	
DIELECTRIC WITHSTANDING VOLTAGE	200 V AC, 1 MINUTE	
DURABILITY	30 CYCLES	
UNMATING FORCE (INITIAL / AFTER TEST)	INITIAL: 5 N MIN. AFTER TEST: 3 N MIN.	INITIAL: 4 N MIN. AFTER TEST: 2 N MIN.
PRODUCT SPECIFICATION	PRS-2105	PRS-2106
TEST REPORT	TR-15059	TR-15060
PACKING STANDARD	PST-17011	
INSTRUCTION MANUAL	HIM-10002	HIM-12010
APPEARANCE CRITERIA No.	QLS-A***	

Rev.4

Accessories for MHF® I Receptacle

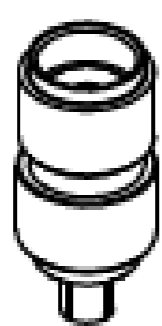

MHF I/II SMA ADAPTOR
PART NO. 90193-002

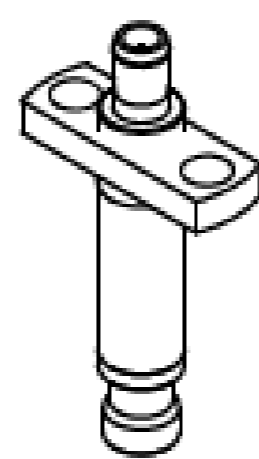

4.5MM HIGH CYCLE TEST PROBE FOR MHF/MHF A
PART NO. 90575-0001

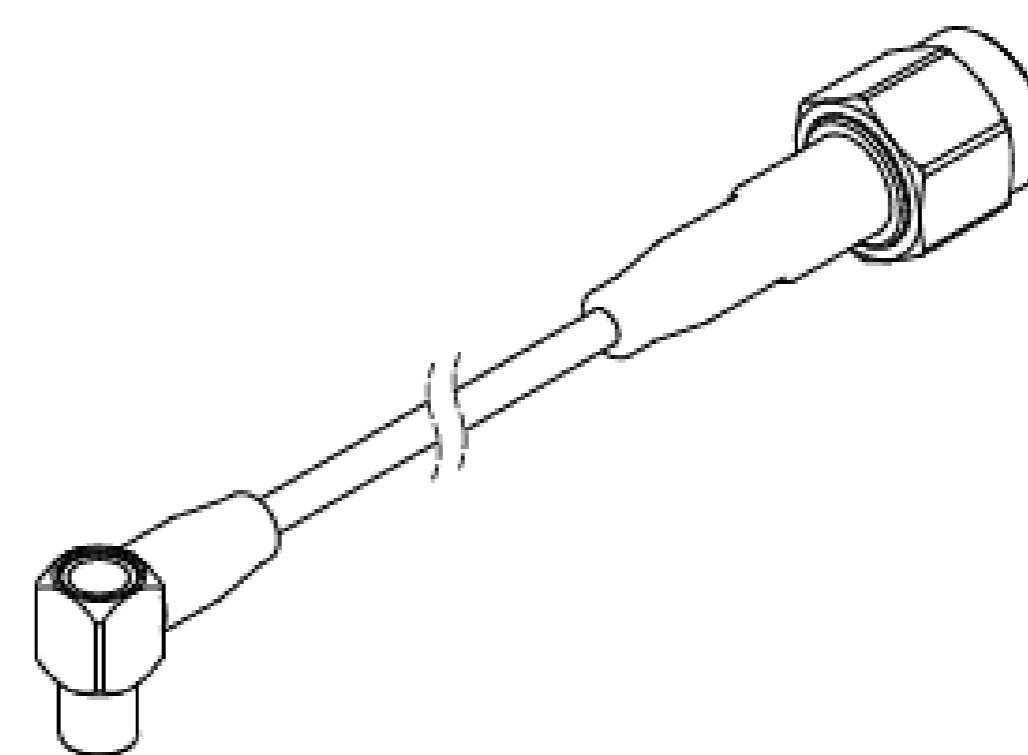

4.5MM HIGH CYCLE TEST PROBE CABLE ASS'Y
PART NO. 90577-****

* 90575-0001 AND 90577-**** SHOULD BE USED TOGETHER.

Rev.4

Board to Board



High-Density



Autolocking FPC/FFC



High-Density



FPC/FFC

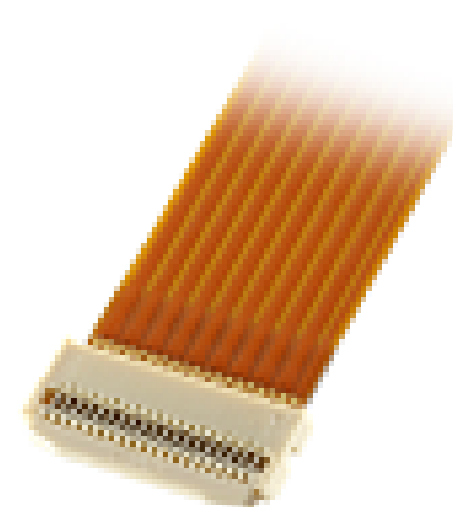

Micro-Coaxial / Discrete Cable



High-Speed



RF



High-Frequency



Optical Module



High-Speed



Effector



Power



High-Power



I/O (Input/Output)

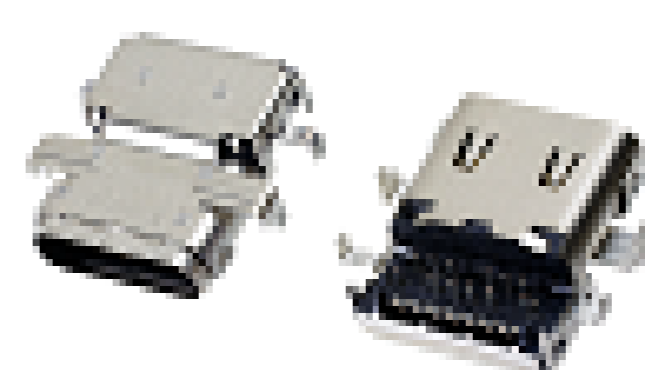

Quick charge



Inquiry



Custom Connectors Available



I-PEX, MHF, CABLINE, NOVASTACK, EVAFLEX, MINIFLEX, ISH, IARPB, IASLP, ESTORQ, ISFIT, i-Fit and ZenShield are registered trademarks of I-PEX Inc. Please note that the contents in the catalog might be changed without prior notification. I-PEX Inc. assumes no responsibility for any inaccuracies or obligation to update Information on these documents. Please be sure to read and understand the latest "Precautions for Use" and "Instruction Manual" before you use our products. We shall not be responsible for any defects, damages or troubles in case you use our products without following the precautions for use. Please feel free to contact our sales representatives when you use our products for any applications that require very high reliability and safety, or that relate to human life (ex. nuclear power control, aerospace, transportation, medical equipment, safety equipment etc.).

Contact your sales representative or more detailed information.

www.i-pex.com

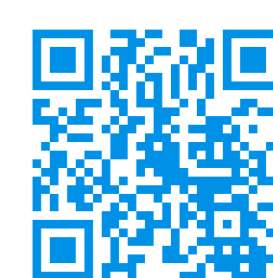

I-PEX

© I-PEX Inc. 2022
All rights reserved.