

SSC3-200A SSC3-200B

12 Volt 200 Amp Intelligent Solid State Contactor



Key Features

- **NEW Innovative SmartStart** adapts and compensates for Resistive, Capacitive, and Inductive Loads.
- **NEW LoadLogic Technology** - Compensates for difficult loads (load startup and faults).
- Over-Current, Under/Over-Voltage, Over-Temperature, and Loss of Ground Fault Protection
- Custom Functions (Timer Delays, Thresholds) are available via Factory Programming (SPCs) - **Contact InPower**
- Compact Size and Low Profile

Technical Description

InPower's SSC3 Series of Universal Solid State Contactors are the ideal solution for intelligently switching power to auxiliary loads. InPower's SSC3 Series replaces outmoded 12V mechanical contactors and uses proven patented solid-state contactor and Cool Terminal technology.

Sophisticated microprocessor algorithms monitor over-current, over-voltage, under-voltage, and over-temperature conditions and create an intelligent switch that can shutdown if dangerous conditions exist. These faults are indicated by a Flashing LED which is normally ON for normal Operation. In addition, LoadLogic technology automatically compensates for different types of loads, starting difficult loads, yet accurately detecting a dead short fault.

The LOAD is connected to the BAT+ when the SSC3 is turned ON by > +8.0V on INPUT. Since the SSC3 is unidirectional, this provides protection for the charging system insuring that current only flows toward the auxiliary load. **(See SSC3 Owner's Manual OM-216).**

Applying a voltage > +8.0 volts to the SSC3 INPUT terminal will turn the SSC3 "ON" connecting the BAT+ to the LOAD terminal. A voltage of <+4.0 volts control turns the SSC3 "OFF" isolating the two terminals. This can be controlled manually via a switch, or by connecting the INPUT to the Ignition signal so that all loads are switched off automatically with the ignition.

InPower's SSC3 200 Amp Solid State Contactors are available in 2 and 4 Lug models. The 4 Lug model allows the SSC3 to serve as a high current junction block. Multiple SSC3s of the same rating may be paralleled.

Load Considerations: Relays/Solenoids must incorporate Fly Back Suppression Diodes/Circuitry. These Relays/Solenoids (without suppression) can create large voltage and current spikes which damage electronics. Having inductive loads without suppression violates your unit's warranty and may damage your vehicle's electronics!

In addition, the 4 Lug model allows parallel power cabling between the auxiliary and chassis batteries. Parallel power cabling significantly reduces overall cable cost and increases wiring efficiency. **(See White Paper 1.042. HCC)**

System Diagram

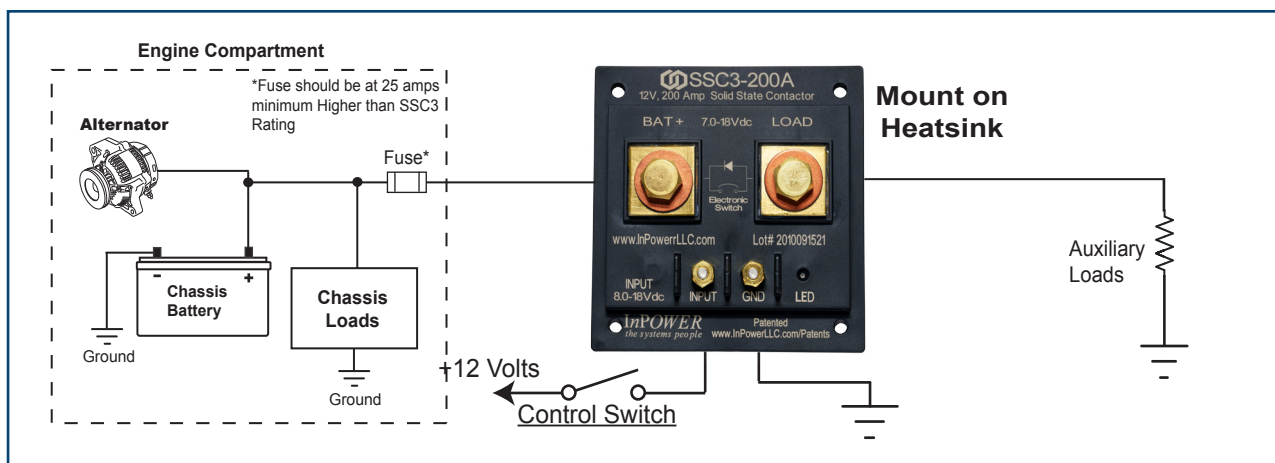

SSC3-200A SSC3-200B

12 Volt 200 Amp Intelligent Solid State Contactor

Specifications

Maximum Current Rating:	SSC3-200A/B 200 Amps
Operating Voltage:	+7.0 to +18.0 volts
Operating Temperature:	-40° to +185° F (85° C)
Low Battery Voltage Trip:	<7.00 for ≥ 250 milliseconds on BAT+
Loss of Ground Trip:	250 milliseconds
Over-Current Trip:	205 Amps +/- 2 Amps for 1 Sec
Shorted Load Detect:	250 milliseconds
LED Indicator:	SW State (ON/OFF), FAULT (FLASH)
Standby Current Draw:	3.8 milliamps max.
Turn-On/Off Delay:	25 milliseconds
INPUT Control Voltage:	>+8.0 VDC ON, <+4.0 VDC OFF
INPUT Resistance:	120 K Ohm to ground
BAT+ to LOAD Leakage:	0.075 milliamps maximum

Mechanical Specifications

Weight:	0.40 lbs
Dimensions:	<i>See Mechanical Drawing Below</i>
Power Terminals:	3/8 - 16 Brass Bolts with Copper Washers
INPUT, GND Terminals:	8-32 4-5 Inch Pounds
Ground Connection:	8-32 Ground stud for connection
Power Terminal Torque:	10 to 15 Foot Pounds
Designed to IP67	

Ordering Guide

Model	Description
SSC3-200A	Solid-state contactor, 200 Amp, 2 Lug
SSC3-200B	Solid-state contactor, 200 Amp, 4 Lug
SSC3-200(AorB)	SPCnnn Custom Configuration

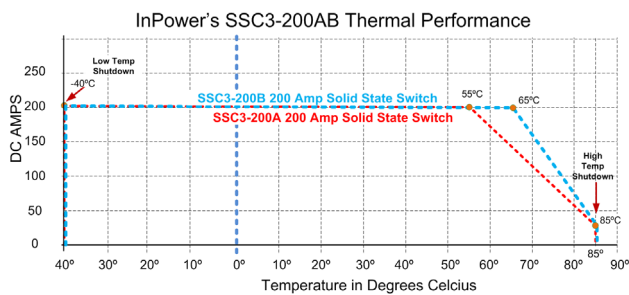

!IMPORTANT!

- Mount unit with 144 sq. inches of > 0.125 sheet metal for proper heat dissipation.
- Not for under-hood mounting
- Only use the supplied 0.50 inch long 3/8 - 16 Brass Bolts and Copper Washers - **Do Not Substitute**
- Protect lugs with boots or dielectric grease

Mechanical Drawing

