

### 650V GaN FET in TO-220 (source tab)

#### Description

The TPH3212PS 650V, 72mΩ Gallium Nitride (GaN) FET is a normally-off device. It combines state-of-the-art high voltage GaN HEMT and low voltage silicon MOSFET technologies—offering superior reliability and performance.

Transphorm GaN offers improved efficiency over silicon, through lower gate charge, lower crossover loss, and smaller reverse recovery charge.

#### Related Literature

- [AN0009](#): Recommended External Circuitry for GaN FETs
- [AN0003](#): Printed Circuit Board Layout and Probing
- [AN0010](#): Paralleling GaN FETs

#### Ordering Information

Part Number	Package	Package Configuration
TPH3212PS	3 lead TO-220	Source

TPH3212PS  
TO-220  
(top view)

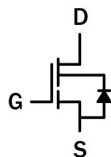
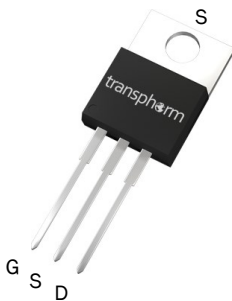

Cascode Schematic Symbol

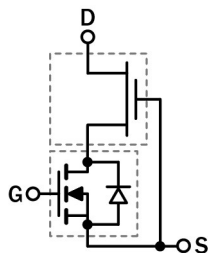

Cascode Device Structure

#### Features

- JEDEC qualified GaN technology
- Dynamic  $R_{DS(on)eff}$  production tested
- Robust design, defined by
  - Intrinsic lifetime tests
  - Wide gate safety margin
  - Transient over-voltage capability
- Very low  $Q_{RR}$
- Reduced crossover loss
- RoHS compliant and Halogen-free packaging

#### Benefits

- Enables AC-DC bridgeless totem-pole PFC designs
  - Increased power density
  - Reduced system size and weight
  - Overall lower system cost
- Achieves increased efficiency in both hard- and soft-switched circuits
- Easy to drive with commonly-used gate drivers
- GSD pin layout improves high speed design

#### Applications

- Datacom
- Broad industrial
- PV inverter
- Servo motor

Key Specifications	
$V_{DSS}$ (V)	650
$V_{(TR)DSS}$ (V)	800
$R_{DS(on)eff}$ (mΩ) max*	85
$Q_{RR}$ (nC) typ	90
$Q_G$ (nC) typ	14

\* Dynamic on-resistance; see Figures 19 and 20

Common Topology Power Recommendations	
CCM bridgeless totem-pole*	2104W max
Hard-switched inverter**	2486W max

Conditions:  $F_{SW}=45kHz$ ;  $T_J=115^\circ C$ ;  $T_{HEATSINK}=90^\circ C$ ; insulator between device and heatsink (6 mil Sil-Pad® K-10); power de-rates at lower voltages with constant current

\*  $V_{IN}=230V_{AC}$ ;  $V_{OUT}=390V_{DC}$

\*\*  $V_{IN}=380V_{DC}$ ;  $V_{OUT}=240V_{AC}$

# TPH3212PS (Discontinued)

## Absolute Maximum Ratings ( $T_C=25^\circ\text{C}$ unless otherwise stated.)

Symbol	Parameter	Limit Value	Unit	
$V_{DSS}$	Drain to source voltage ( $T_J = -55^\circ\text{C}$ to $150^\circ\text{C}$ )	650	V	
$V_{(TR)DSS}$	Transient drain to source voltage <sup>a</sup>	800		
$V_{GSS}$	Gate to source voltage	$\pm 18$		
$P_D$	Maximum power dissipation @ $T_C=25^\circ\text{C}$	104	W	
$I_D$	Continuous drain current @ $T_C=25^\circ\text{C}$ <sup>b</sup>	27	A	
	Continuous drain current @ $T_C=100^\circ\text{C}$ <sup>b</sup>	17	A	
$I_{DM}$	Pulsed drain current (pulse width: 10 $\mu\text{s}$ )	120	A	
$(di/dt)_{RDMC}$	Reverse diode di/dt, repetitive <sup>c</sup>	1400	A/ $\mu\text{s}$	
$(di/dt)_{RDMT}$	Reverse diode di/dt, transient <sup>d</sup>	2800	A/ $\mu\text{s}$	
$T_C$	Operating temperature	Case	-55 to +150	$^\circ\text{C}$
$T_J$		Junction	-55 to +150	$^\circ\text{C}$
$T_S$	Storage temperature	-55 to +150	$^\circ\text{C}$	
$T_{SOLD}$	Soldering peak temperature <sup>e</sup>	260	$^\circ\text{C}$	

Notes:

- In off-state, spike duty cycle  $D < 0.01$ , spike duration  $< 1\mu\text{s}$
- For increased stability at high current operation, see Circuit Implementation on page 3
- Continuous switching operation
- $\leq 300$  pulses per second for a total duration  $\leq 20$  minutes
- For 10 sec., 1.6mm from the case

## Thermal Resistance

Symbol	Parameter	Typical	Unit
$R_{\theta JC}$	Junction-to-case	1.2	$^\circ\text{C}/\text{W}$
$R_{\theta JA}$	Junction-to-ambient	62	$^\circ\text{C}/\text{W}$

# TPH3212PS (Discontinued)

## Circuit Implementation

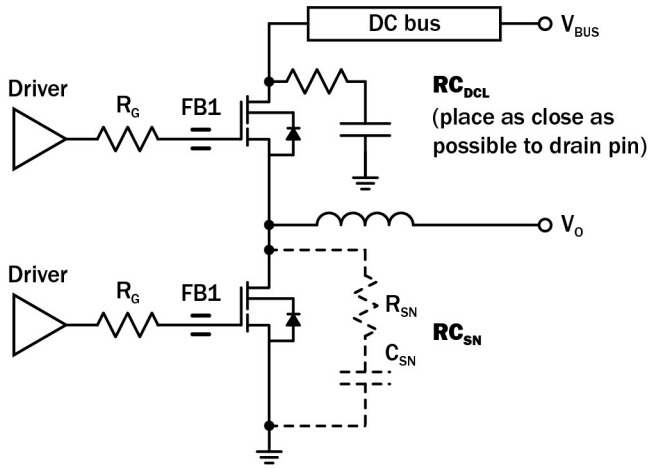

Simplified Half-bridge Schematic

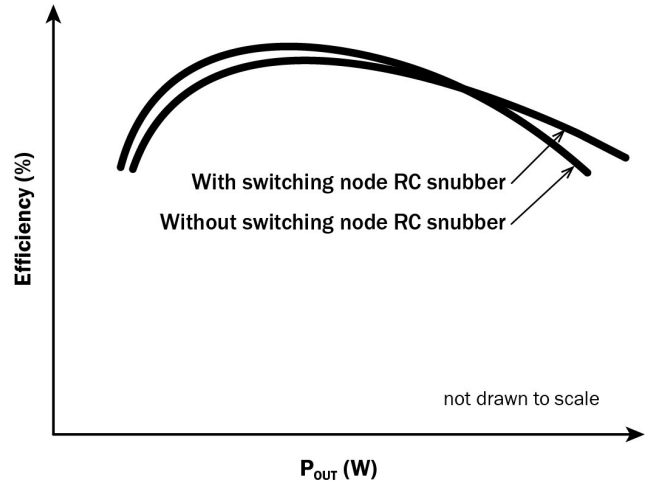

Efficiency vs Output Power

Recommended gate drive: (0V, 8-10V) with  $R_{G(tot)} = 15-20\Omega$ , where  $R_{G(tot)} = R_G + R_{DRIVER}$

Gate Ferrite Bead (FB1)	Required DC Link RC Snubber ( $RC_{DCL}$ ) <sup>a</sup>	Recommended Switching Node RC Snubber ( $RC_{SN}$ ) <sup>b, c</sup>
MMZ1608S181ATA00	10nF + 8 $\Omega$	33pF + 15 $\Omega$

Notes:

- $RC_{DCL}$  should be placed as close as possible to the drain pin
- A switching node RC snubber (C, R) is recommended for high switching currents (>70% of  $I_{RDMC1}$  or  $I_{RDMC2}$ ; see page 5 for  $I_{RDMC1}$  and  $I_{RDMC2}$ )
- $I_{RDM}$  values can be increased by increasing  $R_G$  and  $C_{SN}$

# TPH3212PS (Discontinued)

## Electrical Parameter (T<sub>J</sub>=25 °C unless otherwise stated)

Symbol	Parameter	Min	Typ	Max	Unit	Test Conditions
<b>Forward Device Characteristics</b>						
V <sub>(BL)DSS</sub>	Drain-source voltage	650	—	—	V	V <sub>GS</sub> =0V
V <sub>GS(th)</sub>	Gate threshold voltage	1.6	2.1	2.6	V	V <sub>DS</sub> =V <sub>GS</sub> , I <sub>D</sub> =0.7mA
R <sub>DS(on)eff</sub>	Drain-source on-resistance <sup>a</sup>	—	72	85	mΩ	V <sub>GS</sub> =8V, I <sub>D</sub> =17A
		—	148	—		V <sub>GS</sub> =8V, I <sub>D</sub> =17A, T <sub>J</sub> =150 °C
I <sub>DSS</sub>	Drain-to-source leakage current	—	3	30	μA	V <sub>DS</sub> =650V, V <sub>GS</sub> =0V
		—	12	—		V <sub>DS</sub> =650V, V <sub>GS</sub> =0V, T <sub>J</sub> =150 °C
I <sub>GSS</sub>	Gate-to-source forward leakage current	—	—	100	nA	V <sub>GS</sub> =18V
	Gate-to-source reverse leakage current	—	—	-100		V <sub>GS</sub> =-18V
C <sub>ISS</sub>	Input capacitance	—	1130	—	pF	V <sub>GS</sub> =0V, V <sub>DS</sub> =400V, f=1MHz
C <sub>OSS</sub>	Output capacitance	—	102	—		
C <sub>RSS</sub>	Reverse transfer capacitance	—	13	—		
C <sub>O(er)</sub>	Output capacitance, energy related <sup>b</sup>	—	142	—	pF	V <sub>GS</sub> =0V, V <sub>DS</sub> =0V to 400V
C <sub>O(tr)</sub>	Output capacitance, time related <sup>c</sup>	—	225	—		
Q <sub>G</sub>	Total gate charge	—	14.6	—	nC	V <sub>DS</sub> =400V, V <sub>GS</sub> =0V to 8V, I <sub>D</sub> =17A
Q <sub>GS</sub>	Gate-source charge	—	3.1	—		
Q <sub>GD</sub>	Gate-drain charge	—	3.4	—		
Q <sub>OSS</sub>	Output charge	—	85.7	—	nC	V <sub>GS</sub> =0V, V <sub>DS</sub> =0V to 400V
t <sub>D(on)</sub>	Turn-on delay	—	24	—	ns	V <sub>DS</sub> =400V, V <sub>GS</sub> =0V to 10V, I <sub>D</sub> =18A, R <sub>G</sub> =10Ω
t <sub>R</sub>	Rise time	—	7.5	—		
t <sub>D(off)</sub>	Turn-off delay	—	55.5	—		
t <sub>F</sub>	Fall time	—	5	—		

Notes:

- Dynamic on-resistance; see Figures 19 and 20 for test circuit and conditions
- Equivalent capacitance to give same stored energy as V<sub>DS</sub> rises from 0V to 400V
- Equivalent capacitance to give same charging time as V<sub>DS</sub> rises from 0V to 400V

# TPH3212PS (Discontinued)

## Electrical Parameters (T<sub>J</sub>=25 °C unless otherwise stated)

Symbol	Parameter	Min	Typ	Max	Unit	Test Conditions
<b>Reverse Device Characteristics</b>						
I <sub>S</sub>	Reverse current	—	—	16.5	A	V <sub>GS</sub> =0V, T <sub>C</sub> =100 °C, ≤25% duty cycle
V <sub>SD</sub>	Reverse voltage <sup>a</sup>	—	2.0	—	V	V <sub>GS</sub> =0V, I <sub>S</sub> =17A
		—	1.5	—		V <sub>GS</sub> =0V, I <sub>S</sub> =8.5A
t <sub>RR</sub>	Reverse recovery time	—	35	—	ns	I <sub>S</sub> =18A, V <sub>DD</sub> =400V, di/dt=1000A/ms
Q <sub>RR</sub>	Reverse recovery charge	—	90	—	nC	
(di/dt) <sub>RDMC</sub>	Reverse diode di/dt, repetitive <sup>b</sup>	—	—	1400	A/μs	
I <sub>RDMC1</sub>	Reverse diode switching current, repetitive (dc) <sup>c, e</sup>	—	—	19	A	Circuit implementation and parameters on page 3
I <sub>RDMC2</sub>	Reverse diode switching current, repetitive (ac) <sup>c, e</sup>	—	—	24	A	Circuit implementation and parameters on page 3
(di/dt) <sub>RDMT</sub>	Reverse diode di/dt, transient <sup>d</sup>	—	—	2800	A/μs	
I <sub>RDMT</sub>	Reverse diode switching current, transient <sup>d, e</sup>	—	—	30	A	Circuit implementation and parameters on page 3

Notes:

- a. Includes dynamic R<sub>DS(on)</sub> effect
- b. Continuous switching operation
- c. Definitions: dc = dc-to-dc converter topologies; ac = inverter and PFC topologies, 50-60Hz line frequency
- d. ≤300 pulses per second for a total duration ≤20 minutes
- e. I<sub>RDM</sub> values can be increased by increasing R<sub>G</sub> and C<sub>SN</sub> on page 3

# TPH3212PS (Discontinued)

Typical Characteristics ( $T_C=25^\circ\text{C}$  unless otherwise stated)

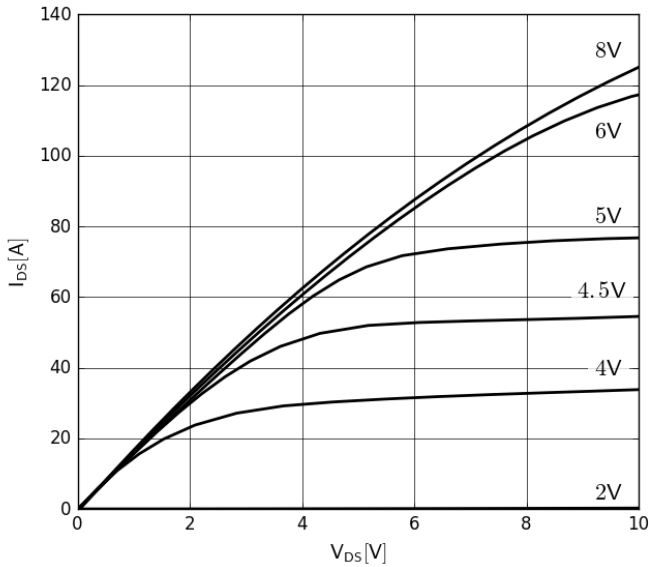

**Figure 1. Typical Output Characteristics  $T_J=25^\circ\text{C}$**   
Parameter:  $V_{GS}$

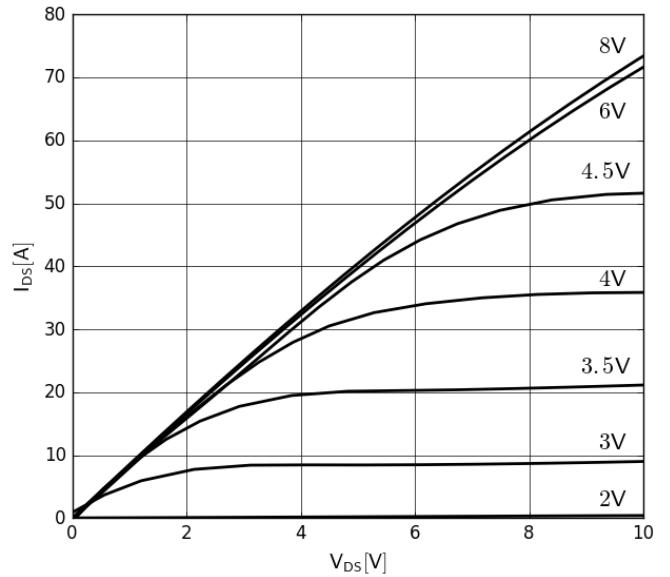

**Figure 2. Typical Output Characteristics  $T_J=150^\circ\text{C}$**   
Parameter:  $V_{GS}$

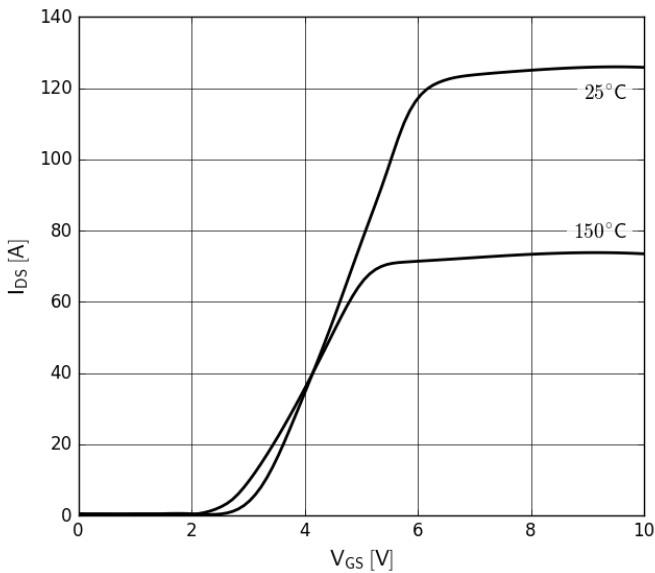

**Figure 3. Typical Transfer Characteristics**  
 $V_{DS}=10\text{V}$ , parameter:  $T_J$

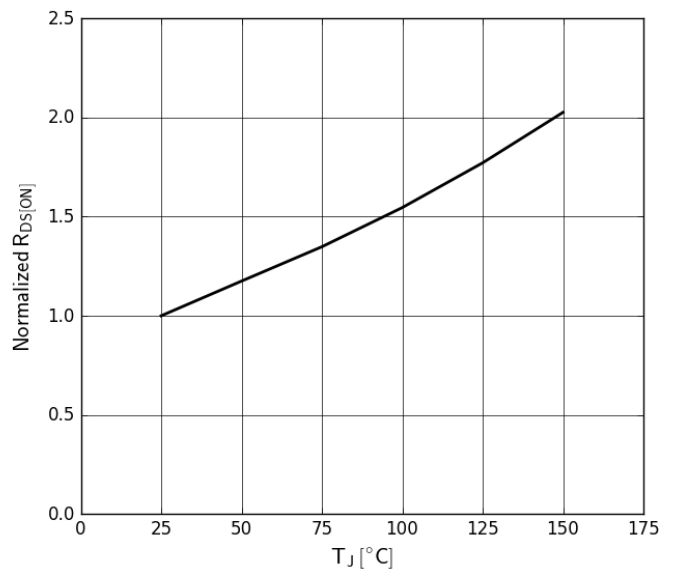

**Figure 4. Normalized On-resistance**  
 $I_D=17\text{A}$ ,  $V_{GS}=8\text{V}$

# TPH3212PS (Discontinued)

Typical Characteristics ( $T_C=25^\circ\text{C}$  unless otherwise stated)

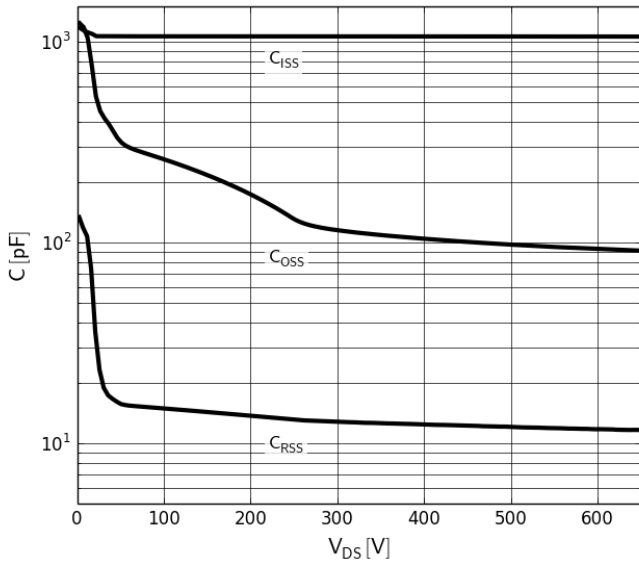

Figure 5. Typical Capacitance

$V_{GS}=0V, f=1MHz$

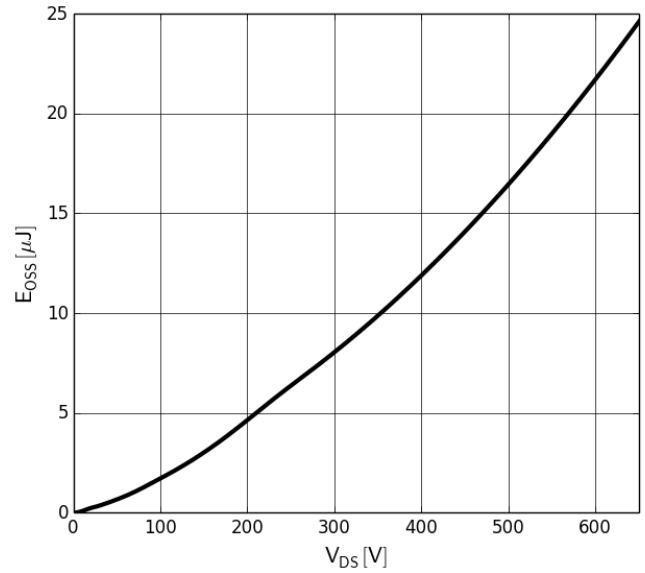

Figure 6. Typical Coss Stored Energy

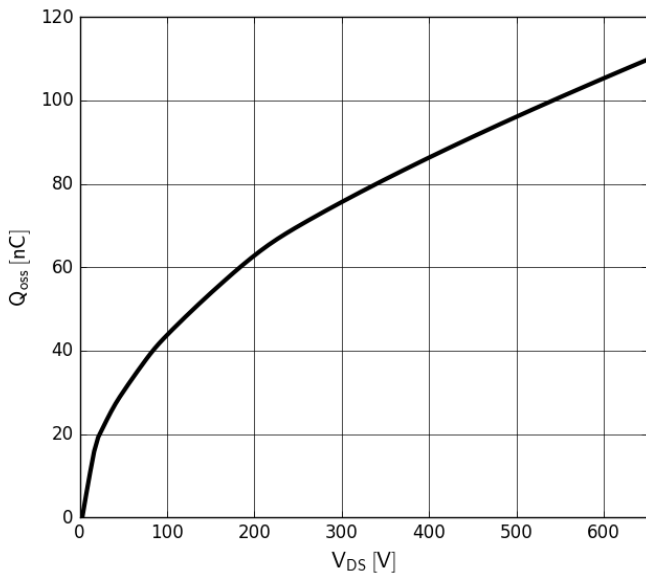

Figure 7. Typical Q<sub>OSS</sub>

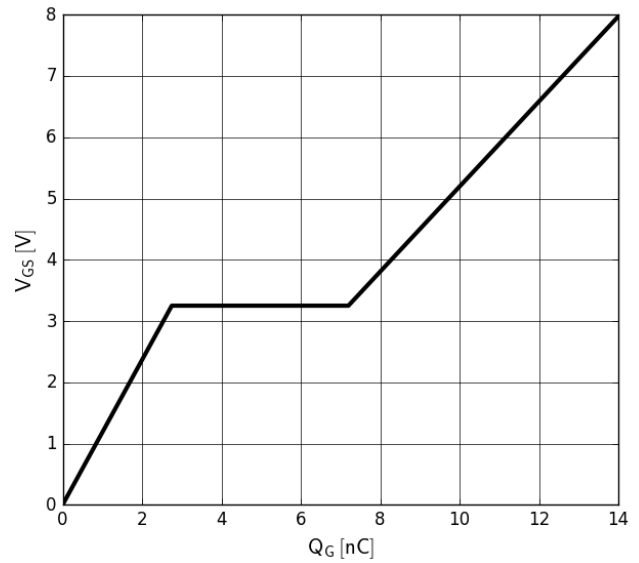
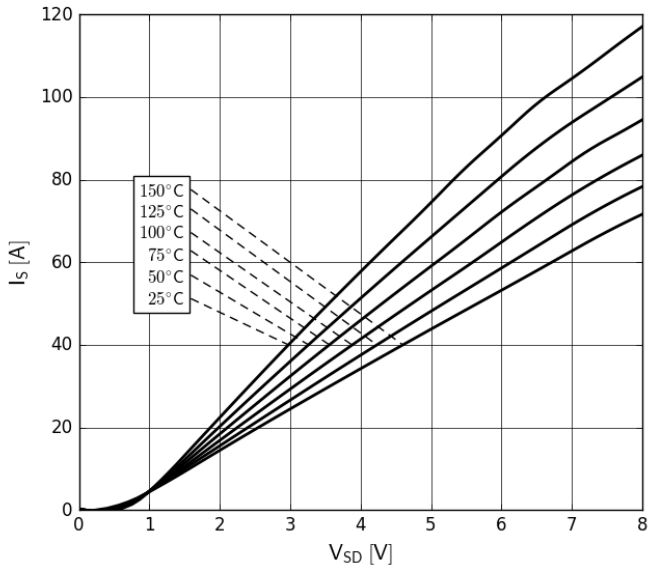

Figure 8. Typical Gate Charge

$I_{DS}=17A, V_{DS}=400V$

# TPH3212PS (Discontinued)

Typical Characteristics ( $T_C=25^\circ\text{C}$  unless otherwise stated)



**Figure 9. Forward Characteristics of Rev. Diode**  
 $I_S=f(V_{SD})$ , Parameter  $T_J$

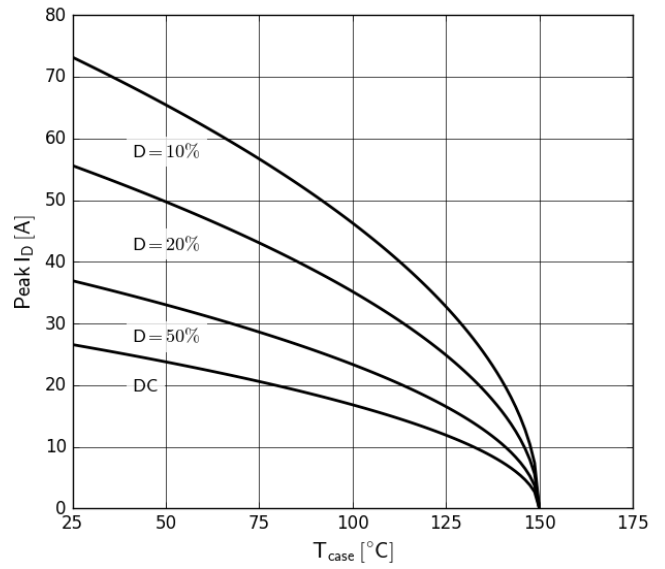

**Figure 10. Current Derating**  
 Pulse width  $\leq 10\mu\text{s}$

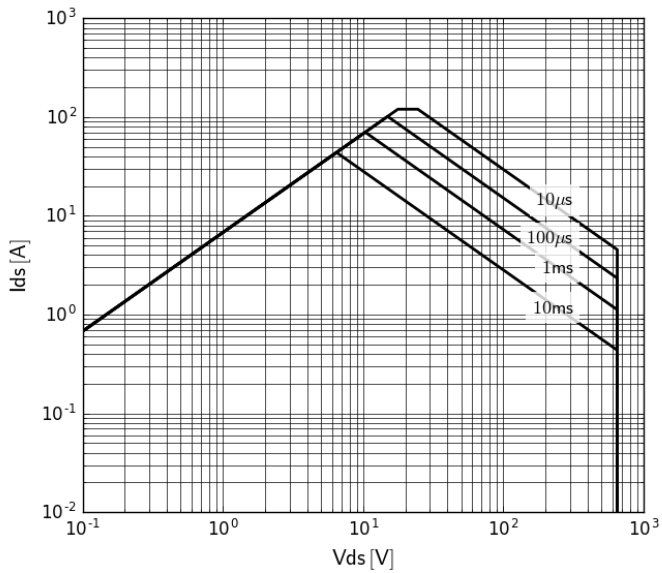

**Figure 11. Safe Operating Area  $T_C=25^\circ\text{C}$**   
 (calculated based on thermal limit)

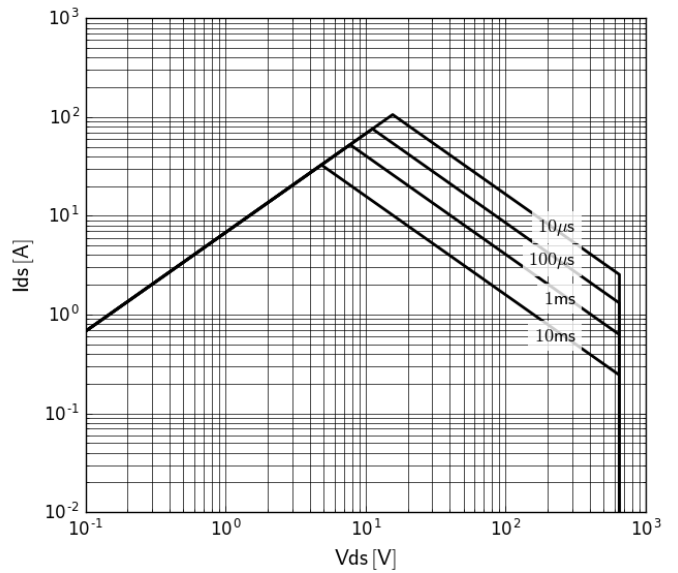

**Figure 12. Safe Operating Area  $T_C=80^\circ\text{C}$**   
 (calculated based on thermal limit)



# TPH3212PS (Discontinued)

Typical Characteristics ( $T_C=25^\circ\text{C}$  unless otherwise stated)

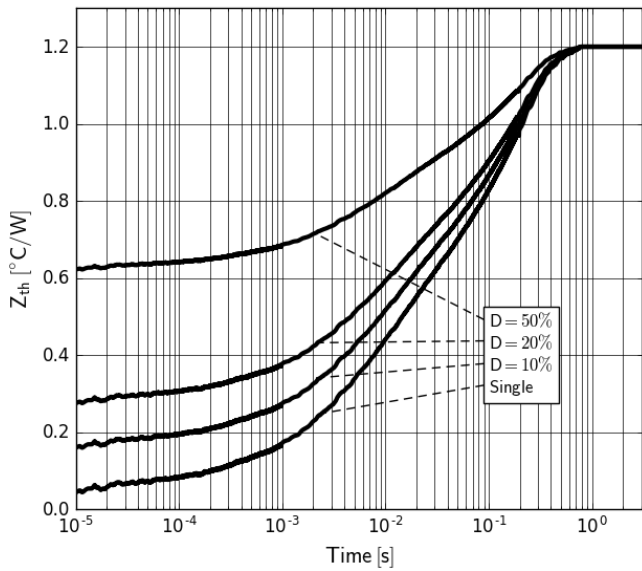

Figure 13. Transient Thermal Resistance

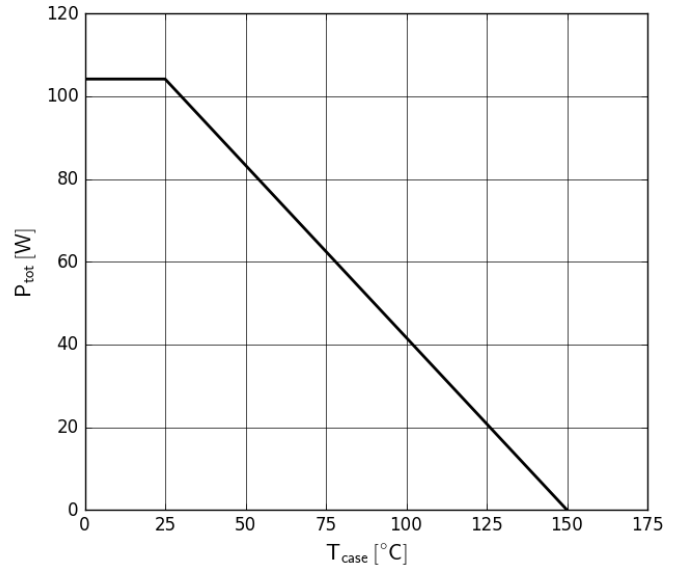
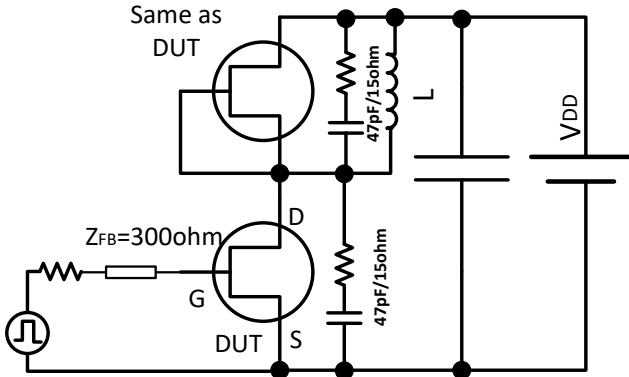

Figure 14. Power Dissipation

# TPH3212PS (Discontinued)

## Test Circuits and Waveforms



**Figure 15. Switching Time Test Circuit**  
(see circuit implementation on page 3 for methods to ensure clean switching)

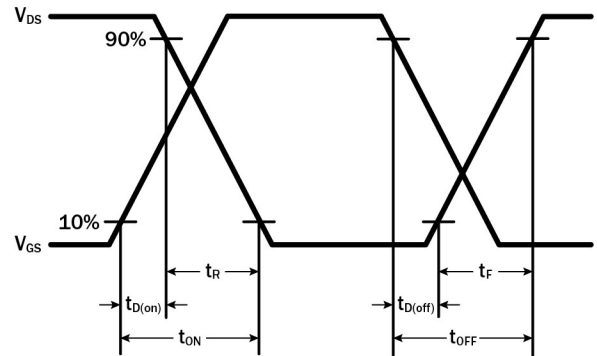

**Figure 16. Switching Time Waveform**

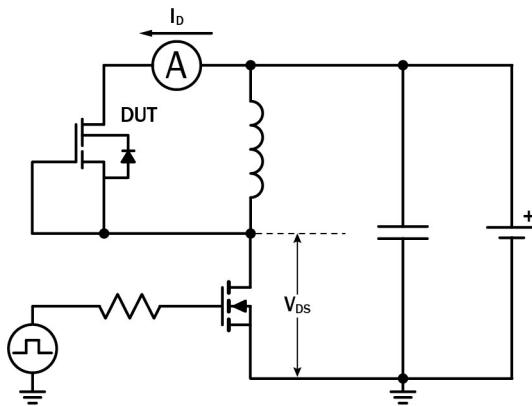

**Figure 17. Diode Characteristics Test Circuit**

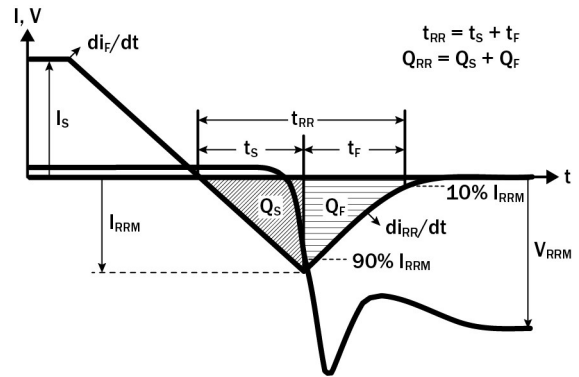

**Figure 18. Diode Recovery Waveform**

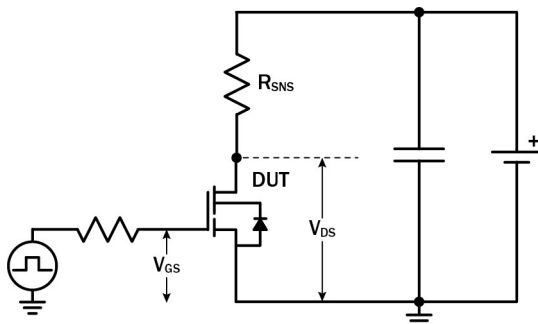

**Figure 19. Dynamic  $R_{DS(on)eff}$  Test Circuit**

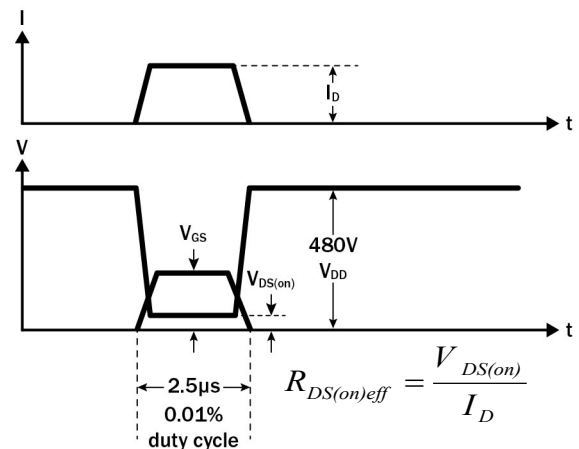

**Figure 20. Dynamic  $R_{DS(on)eff}$  Waveform**

# TPH3212PS (Discontinued)

## Design Considerations

The fast switching of GaN devices reduces current-voltage crossover losses and enables high frequency operation while simultaneously achieving high efficiency. However, taking full advantage of the fast switching characteristics of GaN switches requires adherence to specific PCB layout guidelines and probing techniques.

Before evaluating Transphorm GaN devices, see application note [Printed Circuit Board Layout and Probing for GaN Power Switches](#). The table below provides some practical rules that should be followed during the evaluation.

### When Evaluating Transphorm GaN Devices:

DO	DO NOT
Minimize circuit inductance by keeping traces short, both in the drive and power loop	Twist the pins of TO-220 or TO-247 to accommodate GDS board layout
Minimize lead length of TO-220 and TO-247 package when mounting to the PCB	Use long traces in drive circuit, long lead length of the devices
Use shortest sense loop for probing; attach the probe and its ground connection directly to the test points	Use differential mode probe or probe ground clip with long wire
See <a href="#">AN0003</a> : Printed Circuit Board Layout and Probing	

## GaN Design Resources

The complete technical library of GaN design tools can be found at [transphormusa.com/design](https://transphormusa.com/design):

- Reference designs
- Evaluation kits
- Application notes
- Design guides
- Simulation models
- Technical papers and presentations

# TPH3212PS (Discontinued)

Mechanical

3 Lead TO-220 (PS) Package

Pin 1: Gate; Pin 2: Source; Pin 3: Drain, Tab: Source

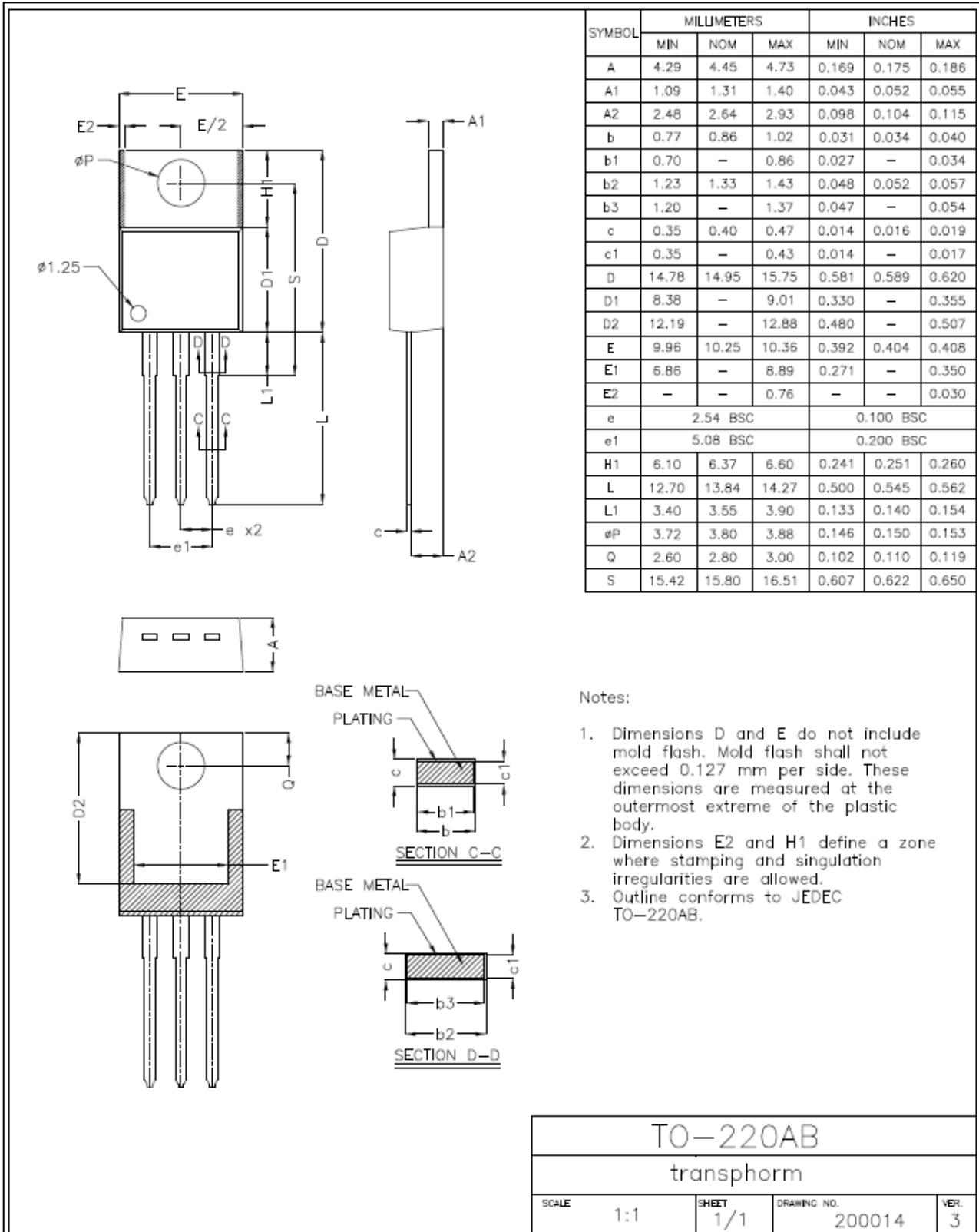

# TPH3212PS (Discontinued)

## Revision History

Version	Date	Change(s)
10	11/14/2016	<b>Added</b> app note AN0009
11	12/12/2016	<b>Updated</b> dynamic measurement verbiage
12	2/15/2017	<b>Updated</b> package drawing; <b>Added</b> app note AN0010
13	11/1/2017	<b>Updated</b> Figures 11 & 12 (pg 7), effective on-resistance symbol to $R_{DS(on)eff}$ to adhere to new JEDEC standards; <b>Added</b> common topology max power recommendations (pg 1), switching current values (pg 2), Circuit Implementation (pg 3), $Q_{OSS}$ value (pg 4), Figures 7 & 8 (pg 6)
14	3/7/2021	Product discontinued