

VEGA-X110

MXM 3.1 Type A Intel Arc A370M Embedded GPU Card with DP1.4a

NEW

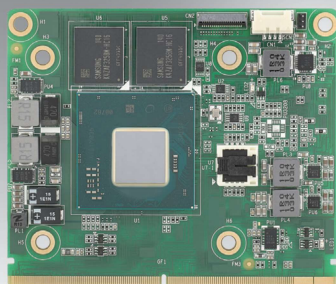

Features

- Intel Arc A370M with 8 Xe-cores, support up to PCI Express 4.0 x8
- MXM Type reliable and suitable for embedded industrial usage
- GPU Clock 1550 MHz Base Clock, GDDR6 4GB 64 bit Memory
- High Resolution 8K DP1.4a x4 Displays Reserved
- TGP 30-40W Low Power Consumption with Optional Thermal kit
- Smart Fan Control by GPU Temperature Automatically
- Power Supply from MXM GPU Card
- 0-60°C Working Temperature Support
- Intel® Deep Link Technologies and OpenVINO support
- DirectX12, OpenGL 4.6, OpenCL 3.0, H.264/H.265 (HEVC)/AV1 hardware encode/decode supported

OpenVINO



FC CE

Specification

		VEGA-X110-00A1
Processor System	GPU	Intel Arc A370M
	Microarchitecture	Xe HPG
	Xe-cores	8
	Intel XMX Engines	128
	Graphics Clock	1550 MHz
	FP32 Performance	4.198 TFLOPS
Memory	Size	4 GB
	Type	GDDR6
	Interface	64 bit
	Bandwidth	112 GB/s
	Speed	14 Gbps
Graphics	DP	Reserved 4x DisplayPort1.4a
	Max Resolution	7680 x 4320@60Hz
	Quad Display	Yes, 4x DP
	Graphics Engine	DirectX12, OpenGL 4.6, OpenCL 3.0 HW Encode: H.264/H.265(HEVC)/AV1 HW Decode: H.264/H.265(HEVC)/AV1/VP9
Signal Interface	PCI Express	MXM 3.1 PCI Express Gen4 x8 with 3.0 Backwards Compatibility
Power	Max Power Consumption	30-40W
Operating	Temperature	0 ~ 60°C (depends on GPU and cooler solution)
Environment	Humidity	40 °C @ 85% relative humidity (non-condensing)
Thermal Solution	Cooling	Fansink (Option) Heat spreader (Option)
Physical	Dimensions (W x D)	82 x 70 mm
	Form Factor	MXM 3.1 Type A
	Power Range	9-20V (Fan control: 12V only)
OS	Linux	Ubuntu 22.04 LTS
	Windows	Windows 11, 10 64bit

Dimensions

Unit: mm

VEGA-X110

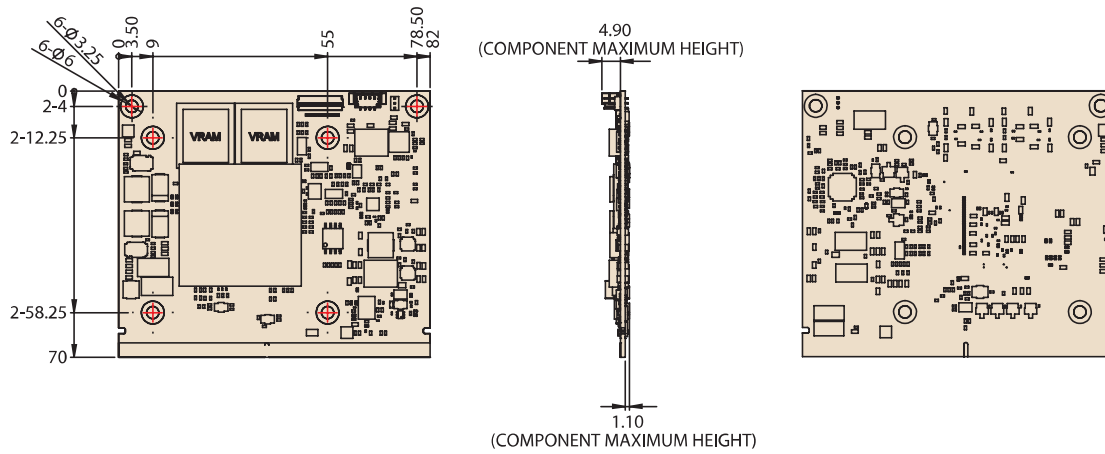

VEGA-X110 with Fansink (option)

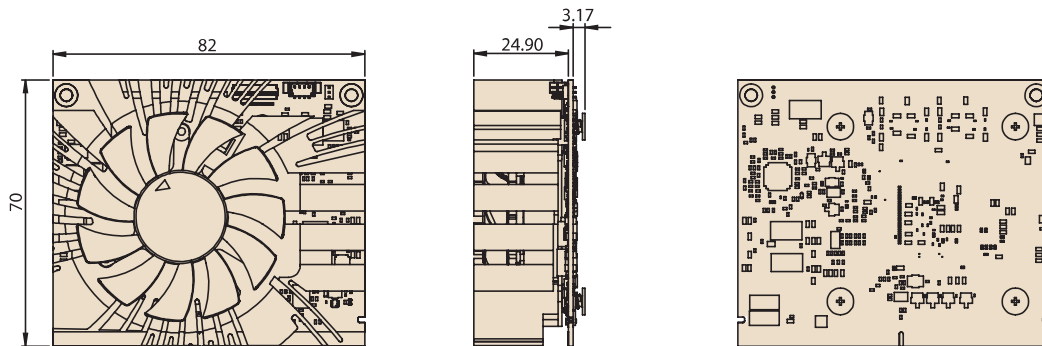

VEGA-X110 with Heat spreader (option)

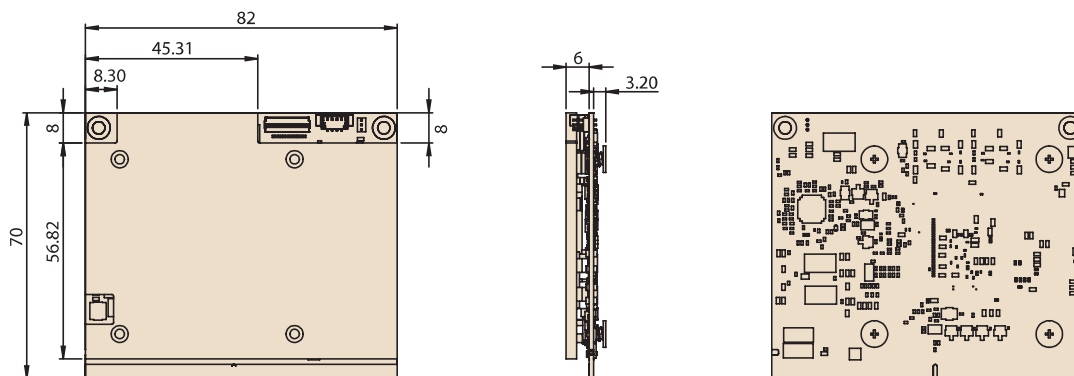

Block Diagram

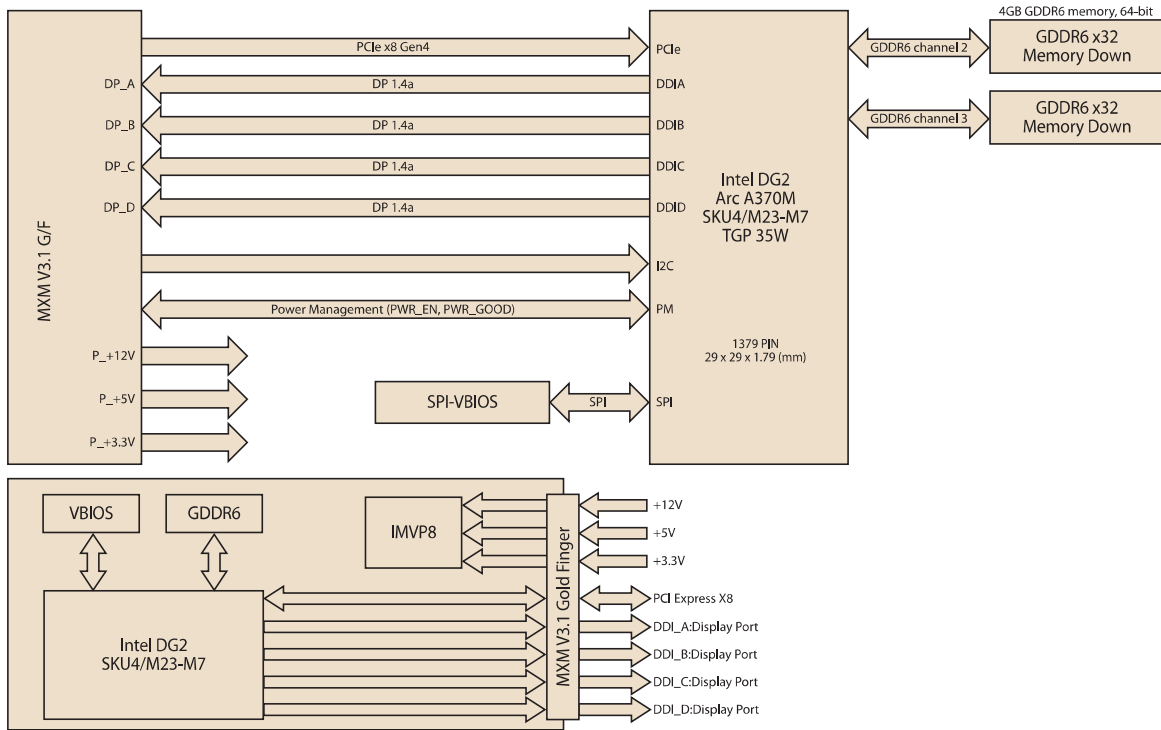

Ordering Information

Part Number	Description
VEGA-X110-00A1	Intel Arc mobile A370M GPU card, MXM

Optional Item

Part Number	Description
1970005694T001	Fansink
-	Heat spreader