

# Lumimax Optoelectronic Technology

## Fixed Inductors/AL0410 Type

### Features:

- Coating epoxy resin that to ensure the humidity resistance to be long life
- Contribute to be high Q and self-resonant frequency
- Low DCR
- RoHS Compliant

### Applications:

- Communication equipment, DC/DC converter
- Computer products
- TV, VCR and electronic products



**AL 0410:** 4mm diameter x 10mm Body Long

Core Material: Ferrite DR Core

Wire: Copper wire

Terminal: Cu/Sn

Coating: Epoxy resin

### Specifications

Type	Inductance (uH)	Q (Min)	Frequency of L/Q ( MHz)	S.R.F (MHz) Min	DC Resistance (Ω) Max	Rated DC Current (mA) Max
AL0410-R22M	0.22±20%	25	25.2	380.00	0.21	880
AL0410-R27M	0.27±20%			340.00	0.24	800
AL0410-R33M	0.33±20%			300.00	0.28	750
AL0410-R39M	0.39±20%			280.00	0.32	680
AL0410-R47M	0.47±20%			250.00	0.36	650
AL0410-R56M	0.56±20%			230.00	0.41	600
AL0410-R68M	0.68±20%			210.00	0.47	550
AL0410-R82M	0.82±20%	45		172.00	0.17	980
AL0410-1R0K	1.0±10%			157.00	0.19	920
AL0410-1R2K	1.2±10%	50		144.00	0.21	880
AL0410-1R5K	1.5±10%			131.00	0.23	830
AL0410-1R8K	1.8±10%	55		121.00	0.25	790
AL0410-2R2K	2.2±10%			110.00	0.28	750
AL0410-2R7K	2.7±10%	60	7.96	100.00	0.30	720
AL0410-3R3K	3.3±10%			94.00	0.34	670
AL0410-3R9K	3.9±10%			86.00	0.37	640
AL0410-4R7K	4.7±10%			80.00	0.39	620
AL0410-5R6K	5.6±110%			74.00	0.43	590
AL0410-6R8K	6.8±10%			68.00	0.48	550
AL0410-8R2K	8.2±10%			53.00	0.52	530
AL0410-100K	10±10%	60	2.52	45.00	0.58	500
AL0410-120K	12±10%			34.00	0.63	480
AL0410-150K	15±10%			20.00	0.72	460
AL0410-180K	18±10%			14.00	0.77	430
AL0410-220K	22±10%			9.90	0.84	410

AL0410-270K	27±10%	50	0.796	7.60	0.94	390
AL0410-330K	33±10%			6.30	1.03	370
AL0410-390K	39±10%			6.30	1.12	350
AL0410-470K	47±10%			6.30	1.22	340
AL0410-560K	56±10%	40		6.20	1.34	320
AL0410-680K	68±10%			5.70	1.47	305
AL0410-820K	82±10%	35		5.30	1.62	290
AL0410-101K	100±10%			4.80	1.80	275
AL0410-121K	120±10%	60		3.80	3.70	185
AL0410-151K	150±10%			3.50	4.20	175
AL0410-181K	180±10%			3.30	4.60	165
AL0410-221K	220±10%			3.00	5.10	155
AL0410-271K	270±10%		2.80	5.80	145	
AL0410-331K	330±10%		2.60	6.40	137	
AL0410-391K	390±10%		2.40	7.00	133	
AL0410-471K	470±10%		2.25	7.70	126	
AL0410-561K	560±10%	55	2.10	8.50	120	
AL0410-681K	680±10%		1.95	9.40	113	
AL0410-821K	820±10%		1.85	10.50	100	
AL0410-102K	1000±10%	50	1.40	14.00	100	
AL0410-222K	2200±10%	55	0.252	0.7	18.00	60
AL0410-332K	3300±10%	55	0.252	0.5	33.00	50

## Dimension Specification

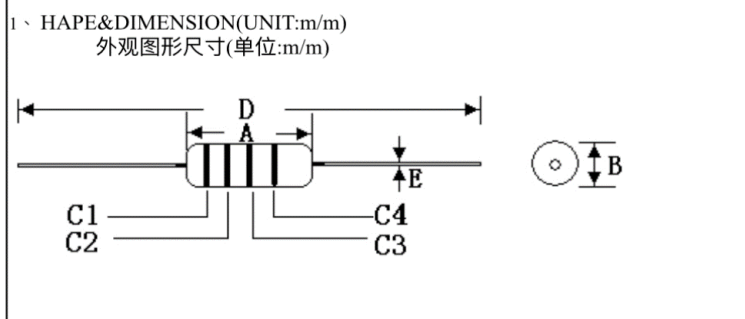

**A: 10.0mm Max.**

**B: 4.0mm Max**

**D: 62.0mm +-2.0mm**

**E: D=0.6+-0.05mm**

**C1, C2, C3, C4 are Color band**

## Packaging:

Qty=1500pcs Taped in one box (Inductance value between 1uH to 1000uH)

Qty=1000pcs Taped in one box (Inductance above 1000uH)

## Reliability and Test Conditions

Item	Specification	Test Method
Solderability	The metalized area must have 90% minimum solder coverages	Dip pads in flux and dip in solder pot (96.5 Sn/3.5 Ag solder) at 255 °C ± 5°C
Resistance to soldering heat	There must be no case deformation or change in dimensions. Inductance must not change more than the stated tolerance	Inductors shall be reflowed onto a PC board using 96.5 Sn/3.5 Ag solder paste. Solder process shall be at a maximum temperature of 260°C. For 96.5 Sn/3.5 Ag solder paste, > 217°C for 90 seconds.
Vibration	There must be no case deformation or change in dimensions. Inductance must be change more than the stated tolerance.	Solder specimen inductor on the test printed circuit board. Apply vibrations in each of the x, y and z directions for 2 hours for a total of 6 hours. Frequency: 10~50 Hz. Amplitude: 1.5mm
High temperature resistance	There must be no case deformation or change in dimensions. Inductance must be change more than the stated tolerance.	Inductor shall be subjected to temperature 85 ± 2°C for 500 ± 12 hours. Measure the test items after leaving the inductors at room temperature and humidity for 2 hours.
Static Humidity	Inductors must not have a shorted or open winding	Inductor shall be subjected to temperature 85 ± 2°C and 90 to 95%RH. for 24 hours. Measure the test items after leaving the inductors at room temperature and humidity for 2 hours.
Component adhesion (Push test)	Inductors shall be subject to 0.9kg	Inductor shall be reflow soldered (255°C± 5°C for 10 seconds) to a tinned copper substrate. A force gauge shall be applied to the side of the component. The device must withstand the stated force without a failure of the termination.
Resistance to Solvent	There must be no case deformation change in dimensions, or obliteration of marking.	Inductors must withstand 6 minutes of alcohol or water.
Low temperature storage	There must be no case deformation or change in dimensions. Inductance must not change more than the stated tolerance	Inductor shall be subjected to temperature -25 ± 2°C for 48 ± 12 hours. Measure the test items after leaving the inductors at room temperature and humidity for 1~2 hours.