

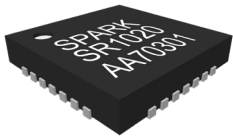

SR1000 SERIES ENHANCING COMMUNICATIONS

**Low Latency
Ultra-low Power
Wireless UWB Transceiver**



SPARK's SR1010 and SR1020 are highly versatile short-range wireless transceivers that enable low latency, ultra-low power data communication up to 6 Mbps. They communicate in the license-free ultra-wideband (UWB) spectrum and facilitates highly robust and energy-efficient communications.

FEATURES

Dynamically reconfigurable UWB spectrum

- SR1010: 3.1 – 5.8 GHz band
- SR1020: 6.0 – 9.3 GHz band
- Up to 3dBm TX power
- RX sensitivity of -75 dBm

UWB PHY layer

- 20.48 MHz symbol rate

Independent 1kbit TX and 1kbit RX FIFOs

Standard SPI interface

1.8 to 3.3 V supply

Industrial operating range: -40 to +85 °C

Package

- 4 x 4 mm 28 pin QFN

KEY BENEFITS

Ultra-low power consumption

- Ideal for aggressively duty-cycled IOT battery-less energy harvesting applications
- Multi-year operation on coin cell battery

Ultra-short latency

- 50 μ s airtime for 1 kbit
- Ideal for real-time data streams such as Headset and HID applications

Coexistence and reduced interference

- BLE, WiFi (2.4, 5 & 6 GHz) and cellular

Low-cost BOM

- 32.768 kHz crystal
- High-efficiency PCB antenna

Support for Carrier-Sense (CSMA) stack

SDK support

Evaluation Kits available

SR1000 SERIES - BLOCK DIAGRAM

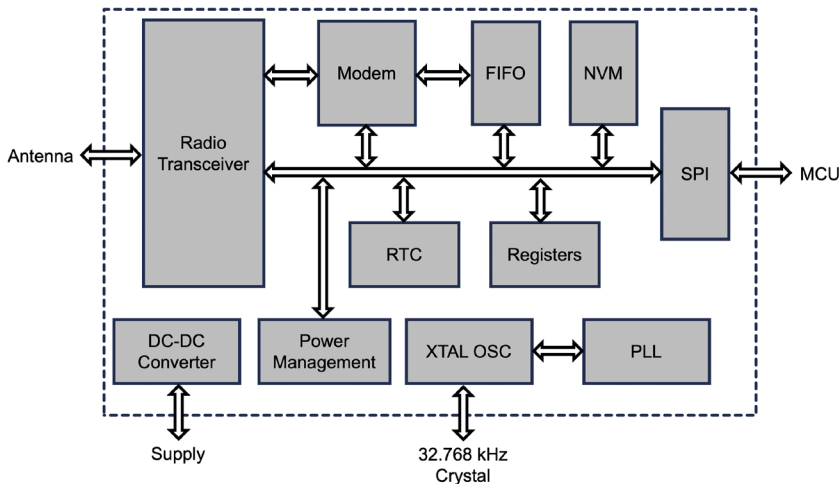

The SR1000 Series is composed of a bidirectional RF section which supports digital & baseband logic, a power management unit, a low power clock input, and a sleep counter. MCU control is achieved via standard SPI interface.

RECONFIGURABLE SPECTRUM THAT IS ROBUST AND SECURE

The SR1000 Series allows for dynamic shaping of its output spectrum to comply with international UWB emission limits. The very low transmitted emission levels are inherently difficult to intercept, enhancing wireless security.

SCALABLE DATA RATE FOR VERSATILE COMMUNICATIONS

The SR1000 Series can achieve data rates from 1 kbps up to 6 Mbps, enabling high throughput applications such as audio/video. Wireless transfer of uncompressed audio is now possible.

ABOUT SPARK UWB

SPARK Microsystems is building next generation short-range wireless communication devices. SPARK UWB provides high data rate and very low latency wireless communication links at an ultra-low power profile, making it ideal for personal area networks (PANs) used in mobile, consumer and IoT-connected products. Leveraging patented technologies, SPARK Microsystems strives to minimize and ultimately eliminate wires and batteries from a wide range of applications. For more information, please visit sparkmicro.com.



CONTACT US

1751 Rue Richardson, Suite 3.300
Montréal, QC, Canada, H3K 1G6
Tel: +1 (438) 375-3990

NORTH AMERICA: NA_sales@sparkmicro.com
EMEA: EMEA_sales@sparkmicro.com
APAC: APAC_sales@sparkmicro.com



ULTRA-LOW POWER CONSUMPTION FOR ENHANCED BATTERY LIFE

The SR1000 Series is aggressively duty-cycled in order to achieve orders of magnitude better energy efficiency compared to traditional IOT solutions. Moreover, ultra-low power consumption is well-suited to operation with energy harvesting technologies.

ULTRA-LOW LATENCY FOR REAL-TIME COMMUNICATIONS

The SR1000 Series ultra-short latency enables wireless implementations for systems that were traditionally only achievable using wires.

ORDERING INFORMATION

PART NUMBER	PACKAGE	BODY SIZE	QUANTITY
SR1020AB-4Q28-CT	QFN28	4x4 mm	1
SR1020AB-4Q28-TR	QFN28	4x4 mm	5000
SR1010AB-4Q28-CT	QFN28	4x4 mm	1
SR1010AB-4Q28-TR	QFN28	4x4 mm	5000