

TELESCOPIC LIFT SYSTEM

Ergo I[®]

ERGOTRONIX



Description

The Ergo-I positioning systems provide the operator full flexibility to move work to any work height positions. This versatile, compact lift column enables smooth, precise and simple up or down adjustments for any application up to 1,200 pounds per pillar.

Application

Unlimited applications in any industry.

- Manufacturing
- Offices: Adjustable furniture, tables, etc.
- Medical: Adjustable tables, beds, chairs, etc.
- Explosion proof environments (pneumatic).

Ergonomic Benefit

- Eliminate employee strain, fatigue and injury.
- Create a safer and more productive work environment.

Standard Features

- Designed and built in the USA for the most robust and heavy-duty applications.
- Self contained, ready-to-use, electrically or pneumatic operated lift system.
- Maintenance free and safe with no pinch points.
- Compact, tough aluminum construction with only a 10-inch footprint.
- Easily adjustable height profiles serve as structural support for each application.
- Hand pendant, foot pedal or programmable up/down control.
- Use any number of synchronized pillars simultaneously to manage any job.
- Pillars available in 400, 800, and 1200 lbs. load capacities at various stroke lengths.
- Electrically operated 120VAC, 220VAC, 12VDC, 24VDC or 80PSI shop air.
- Built in micro switches limits the stroke at each end position.
- Thermal switches provide overload protection in electric version.

Application Examples



Solutions

CONVEY AND TRANSFER • LIFT • LIFT AND TRANSPORT • POSITION

TECHNICAL INFORMATION

AC MODELS: 110VAC OR 220VAC

Model No.	Capacity (lbs.)	Travel (in.)	Retracted Height (in.)	Raised Height (in.)	Lift Speed in/sec.	Duty Cycle
EI 40-12-XX	400	12	19.5	31.5	1.2	20%
EI 40-16-XX	400	16	23.5	39.5	1.2	20%
EI 80-12-XX	800	12	19.5	31.5	0.55	20%
EI 80-16-XX	800	16	23.5	39.5	0.55	20%
EI 120-12-XX	1200	12	19.5	31.5	0.34	10%
EI 120-16-XX	1200	16	23.5	39.5	0.34	10%

SYNCHRONIZED MODELS: 110VAC OR 220VAC

Model No.	Capacity (lbs.)	Travel (in.)	Retracted Height (in.)	Raised Height (in.)	Lift Speed in/sec.	Duty Cycle
EI 120-12S-XX	1200	12	19.5	31.5	0.26	10%
EI 120-16S-XX	1200	16	23.5	39.5	0.26	10%

NOTE: Models EI 120-12S & EI 120-16S require an external Control Unit (Part #EI-CB) for synchronized movement of up to three Ergo-I units.

DC MODELS: 12 VDC OR 24VDC

Model No.	Capacity (lbs.)	Travel (in.)	Retracted Height (in.)	Raised Height (in.)	Lift Speed in/sec.	Duty Cycle
EI 40-12-XX	400	12	19.5	31.5	1.2	100%
EI 40-16-XX	400	16	23.5	39.5	1.2	100%
EI 80-12-XX	800	12	19.5	31.5	0.55	100%
EI 80-16-XX	800	16	23.5	39.5	0.55	100%
EI 120-12-XX	1200	12	19.5	31.5	0.34	100%
EI 120-16-XX	1200	16	23.5	39.5	0.34	100%

PNEUMATIC MODELS: 80PSI SHOP AIR

Model No.	Capacity (lbs.)	Travel (in.)	Retracted Height (in.)	Raised Height (in.)	Lift Speed in/sec.	Duty Cycle
EI140-12PNEUM	400	12	23.5	35.5	Adjustable	100%

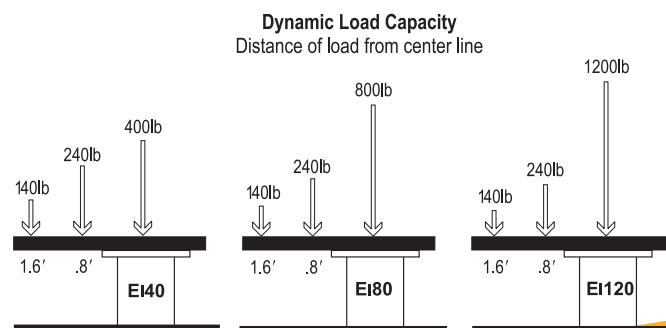
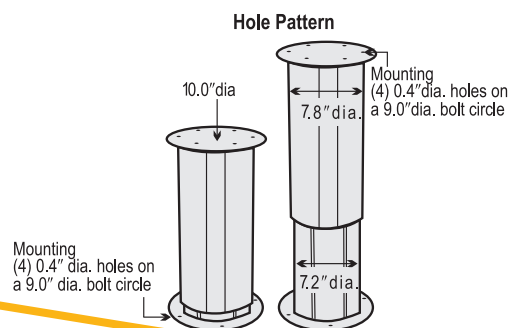

Call us today at 877-SEE-ERGO (877-733-3746) • sales@ergotronix.com • www.ergotronix.com

Rev E, 105, 6/2021
© All rights reserved
Ergotronix, Inc. 2021