



Quality Through Innovation Since 1987

Comparison of Important Design Specs for JFETs Used in Small Signal Applications

Junction field effect transistors (JFETs) are used and are useful in many different circuit topologies. Because these devices function as voltage controlled current sources (VCCS) as opposed to current controlled current sources (CCCS), they offer designers certain flexibilities in designs not available when using bipolar transistors (which are CCCS devices). JFETs can also be used as voltage controlled variable resistors and voltage-controlled switches. JFETs have extremely high input impedances (on the order of giga-ohms) and extremely low input leakage currents (on the order of pico-amps). Selected parts are designed to have excellent performance in high and very high frequency (VHF) circuits.

Parameters to consider:

When designing with JFETs, the design engineer must consider the various device parameters. The most commonly used parameters are:

- V_{GS} – breakdown voltage of the gate-to-source [diode] junction;
- I_{DSS} – drain to source saturation current at some specified drain to source voltage (V_{DS}) and gate voltage (V_{GS}); V_{GS} is usually set to 0.0 V – i.e., gate is connected to source;
- $V_{GS(OFF)}$ – gate-to-source voltage that causes virtually no current flows from drain to source; conduction channel is "pinched off" – sometimes referred to as pinch-off voltage;
- V_{GS} – gate to source operating voltage; the gate-to-source voltage needed to get some specified drain current to flow with some specified V_{DS} ;
- I_{GSS} – the current flow through the gate-to-source diode when it is reverse biased; measured at some specific reverse voltage and with a specified V_{DS} ;
- G_{fs} – transconductance – the ratio of the [output] drain current to the [input] gate voltage; stated as amps per volt, the reciprocal of ohms – measured in Siemens and measured at some specified V_{DS} , I_D , and frequency;
- e_n – voltage noise spectral density measured at some specific V_{DS} , I_D , frequency, and noise bandwidth; units of measurement are noise voltage-per-root hertz, typically written as (e.g.) nV/VHz;
- C_{ISS} – common source input capacitance; useful in circuits operating at high audio frequencies and beyond;
- C_{RSS} – common source reverse transfer capacitance; again, useful in the higher frequency circuits;
- $R_{DS(on)}$ – on resistance, drain to source; measured at some specific V_{DS} , I_D , and frequency; generally, only specified for devices intended for use as voltage variable resistors or voltage-controlled switches.

For any design, whether audio frequency, radio frequency (RF), signal switching, signal attenuation, amplification, or signal shaping, the design engineer must trade off between parameters. There are no perfect devices; the engineer must decide on whether, for example, e_n or I_{DSS} or G_{fs} or V_{GS} is the driving force in a design. In addition to these considerations, when gain stages are configured as differential amplifier pairs, it is necessary to carefully match the two transistors used in each differential pair. Specifically, attention must be paid to the matching of characteristics such as differential $V_{GS(OFF)}$, V_{GS} , I_{DSS} , G_{fs} , C_{ISS} , and C_{RSS} . A further complication arises if the temperature coefficients (tempco) of the devices don't track. The degree of matching of all these parameters in dual devices predominantly affects common mode rejection ratio (CMRR) and offset voltage.

The best way to mitigate these mismatch problems is to use dual JFETs constructed on the same chip (i.e., monolithic JFET pairs). These inherently have very tight parameter matching and tracking. Examples of such parts are our [LSK389](#), [LSK489](#), and [LSJ689](#). Besides the excellent matching, these parts are among the lowest noise parts available. A careful search for low noise JFETs *may* turn up lower noise devices, but none with a good mix of low noise, low I_{DSS} , well matched parameters, and monolithic construction.

Further consideration of low noise device applications:

Low noise amplifier circuits can be implemented by selecting JFETs with very low e_n . The combination of low noise and extremely high input impedance make them the perfect choice in pre-amp and frequency shaping circuitry for:

- high-end audio devices such as dynamic, ribbon (capacitive), or electret microphones;
- high-end audio devices such as moving coil/moving magnet phono cartridges;
- industrial transducers such as inductive pickups, accelerometers, or piezo vibration sensors;

- scientific sensor pre-amps such as those used with electrometers, photo-diodes, photo-multiplier tubes, or Geiger-Müller radiation detector tubes;
- bio-medical sensor pre-amps used in blood pressure, blood oxygen level, respiration rate, galvanic skin response, EKG, and ECG measurements.

A careful design can produce an e_n of 0.7nV/VHz. More detailed applications information regarding designing for low noise can be found in three of our applications notes: [LSK389 Application Note](#), [LSK489 Application Note](#), and [LSJ689 Application Note](#).

The extremely high input impedances and extremely low input leakage currents cited above are two of the more important parameters of JFETs when used in scientific sensor applications (again, electrometers, photo sensors, or Geiger-Müller tubes).

Further information on general JFET designs can be found in the LSK389 Application Note cited above along with an app-note originally published by Siliconix, [AN102, JFET Biasing Techniques](#).

Low or ultra-low power applications:

Low power-draw topologies are easily implemented by selecting JFETs with an I_{DSS} of 2 to 6 mA and low $V_{GS(OFF)}$. These will prove useful in circuitry used in portable equipment that is powered from batteries. Another low power class of devices uses power scavenged from the surrounding environment. This includes (but is not limited to):

- equipment powered from light sources using solar/photo-voltaic cells;
- equipment powered from heat using thermocouples/thermopiles;
- equipment powered from mechanical motion/vibration using piezo-ceramic elements;
- equipment powered from mechanical motion such as ocean waves or wind using electromechanical generators;
- equipment powered from ambient RF or magnetically coupled energy.

Low power amplifier and oscillator examples:

Two examples of JFET amplifier circuitry are taken from the LSK489 Application Note previously cited and reproduced below in Figure 1. On the left, the matched pair (LSK489) is a low current draw (2 mA) differential source follower that buffers the input to an op-amp. By selecting a low power op-amp, overall power draw can be quite low. On the right, the differential pair is reconfigured as a drain follower which not only buffers but also adds significant voltage gain.

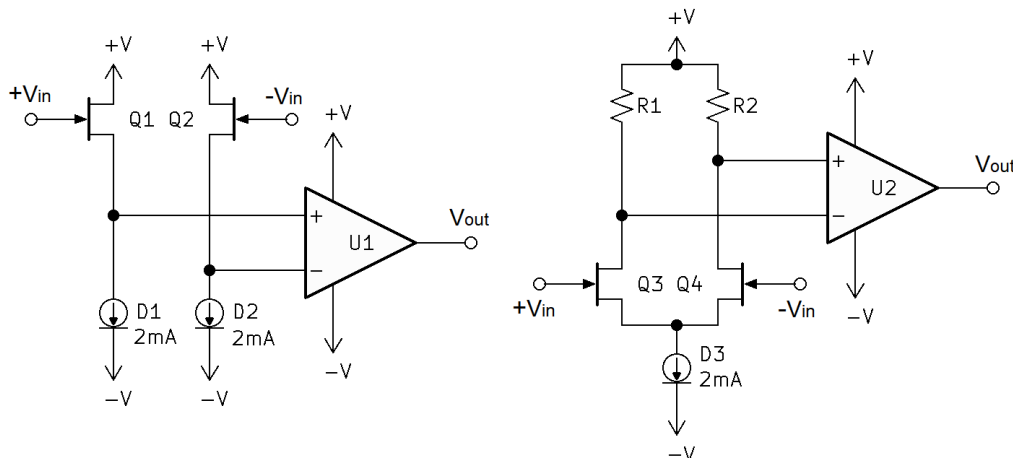

Figure 1

An example of a stand-alone JFET amplifier stage, again taken from the LSK489 Application Note, is shown in Figure 2. As configured, current draw is 4 mA.

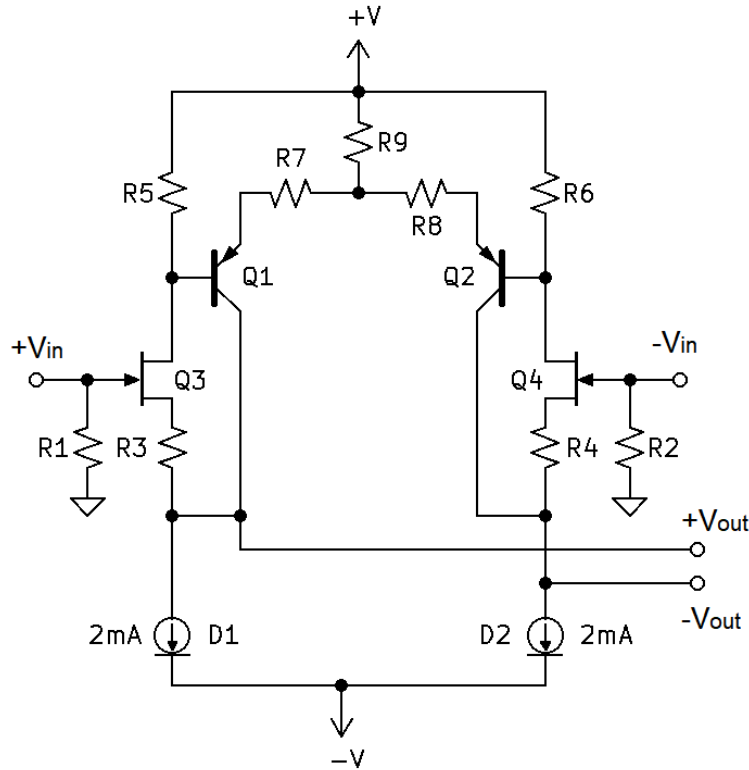

Figure 2

Two examples of ultra-low power oscillators are shown in Figures 3a and 3b, both built with one JFET (our [LSK170A](#)). Figure 3a is a Hartley oscillator. C2 and C3 are coupling and power supply bypass capacitors (respectively); as such, typical values can be 0.1 uF. A typical value for R1 is 1.0 Meg-Ω. C1 and L1 are selected to parallel resonate at the desired frequency of operation which can be from audio frequencies to VHF. A prototype circuit using a selected LSK170A, a J. W. Miller B5496C tapped coil, and a 10pF capacitor for C1 worked with a supply voltage of 105 mVDC and a current draw of 166 uA. Resonant frequency was 4 MHz.

Figure 3b is an Armstrong oscillator. C4, C5, and R2 are functionally equivalent to C3, C2, and R1 above. T1 is a Toko RAN 10A 6845 RF coupling transformer with a 1:40 voltage turns ratio (measured at 100kHz). A prototype circuit using a selected LSK170A oscillated at 860 kHz with a supply voltage of 20 mV and current draw of 86 uA.

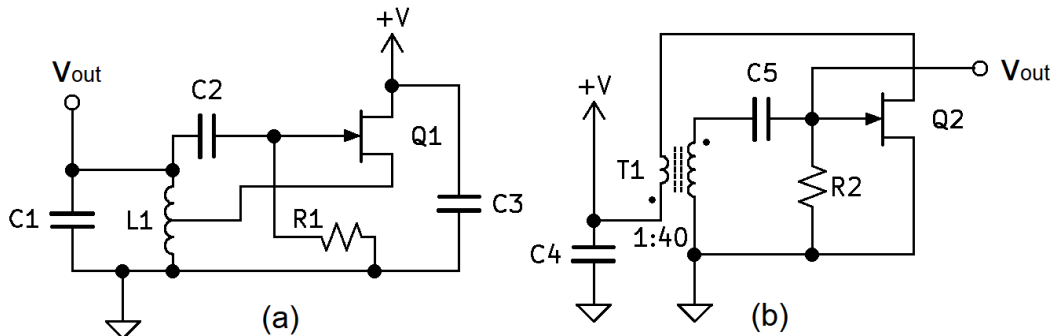

Figure 3

Voltage controlled attenuators or switches:

While all JFETs can be used as voltage controlled variable resistors, certain JFETs are manufactured and characterized for this specific application. They are typically used with no DC voltage applied from drain to source and instead have just an AC signal applied (capacitively coupled). Varying the voltage at the gate with respect to the source varies the drain to source resistance.

An example circuit using a P-channel JFET (Linear Systems [LS26VPS](#)) as part of a simple two-resistor voltage divider is shown in Figure 4. R1 is the upper resistor and Q1's drain to source resistance is the lower resistor. A signal applied at the V_{in} terminal will be attenuated and appear at the V_{out} terminal. An increasingly positive voltage applied to V_{CNTL} increases the drain to source resistance and reduces the attenuation factor. This circuit can be used as an adjustable attenuator or a voltage-controlled switch.

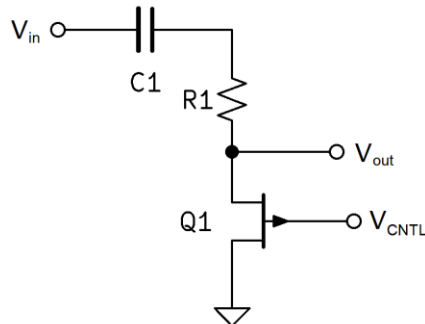

Figure 4

More detailed applications information can be found in our applications note [A Guide to Using FETs for Voltage Controlled Circuits](#).

RF or VHF applications:

In most high frequency amplifier circuits, rather than using a broadband amplifier as is used in low frequency audio and servo circuits, tank (L-C) circuits are added to the input and output ports of the amplifier stage and are tuned to specific frequencies. Such a stage is referred to as a tuned gate/tuned drain amplifier. It has very high input impedance and can provide frequency-selective high gain. A simplified example is shown in Figure 5.

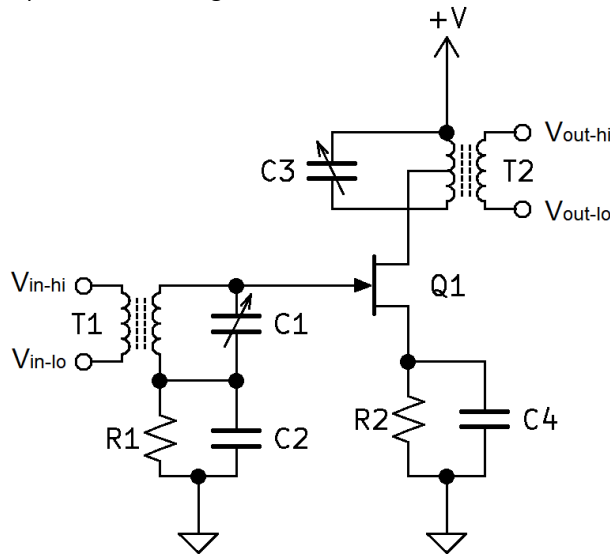

Figure 5

A variation on this circuit is the tuned source/tuned drain common gate amplifier shown in Figure 6. It has relatively low input impedance. In some applications, this circuit has higher stability (lower likelihood to exhibit parasitic oscillation).

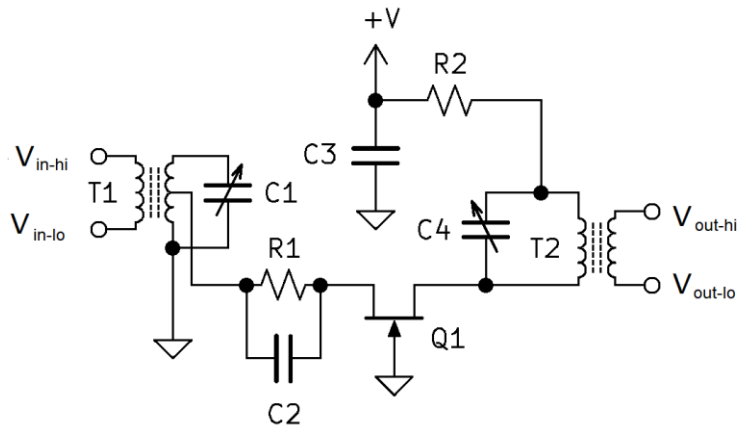

Figure 6

When oscillations *are* desired and frequency accuracy is important a crystal-controlled oscillator is needed. Figure 7 shows a Pierce oscillator.

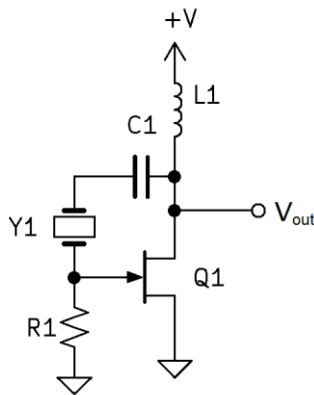

Figure 7

Switch-mode power supply application:

The circuit in Figure 8 shows a variation on an Armstrong oscillator seen in Figure 3b, above. With this circuit, when first powered, the load remains disconnected. Once the oscillations have risen to a sufficiently high level, i.e., when the rectified voltage at C2 rises above the gate threshold voltage of the P-channel enhancement mode MOSFET Q2, it turns on and provides current to the load.

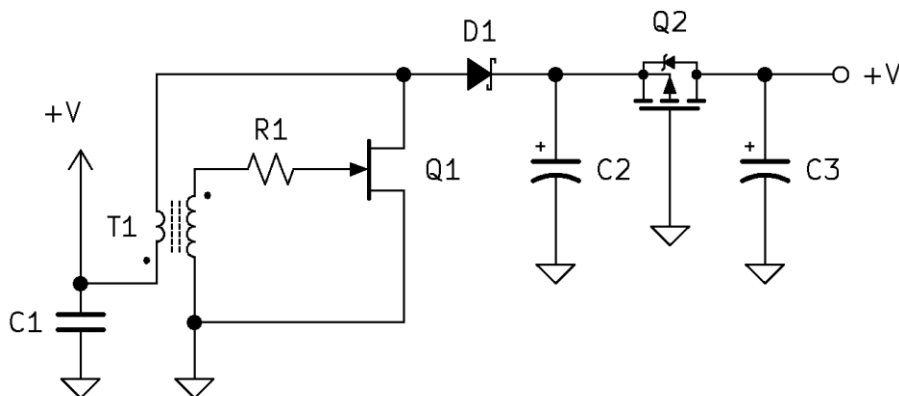

Figure 8

For a more detailed look at switch-mode power supplies that can operate on extremely low voltages, see the Analog Devices App Note by Jim Williams, [J-FET-Based DC/DC Converter Starts and Runs from 300mV Supply](http://www.linear.com/appnote/AN-11).

Conclusion:

General purpose amplifier topologies – the pre-amp and level-shifting stages of power and servo-amplifiers – and high frequency (RF) amplifiers benefit from the use of JFETs. Further, in demanding low and ultra-low power applications, JFETs are unequaled in their superior performance.