



OPTAN™

OPTAN® BALL LENS

Data Sheet Updated January, 2023

FEATURES

- Tight Radiation Pattern of 15°
- Precise peak wavelength bins from 250 nm – 275 nm
- Bounded low Signal-to-Noise Ratio
- Robust, hermetic through-hole package

BENEFITS

- Integrated optics reduce assembly cost and size requirements
- Narrow emission spectrum is ideal for fixed wavelength detectors
- Instant on/off measurement capability
- Low power, long life emitter ideal for remote and field systems

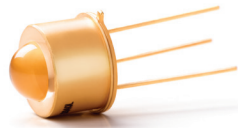

real-time monitoring



swarm sensing



digitize water

SUGGESTED WAVELENGTH RANGE FOR COMMON PARAMETERS

Parameter	250 nm - 260 nm	260 nm - 270 nm	270 nm - 275 nm
EPA UV 254/SAC	•		
COD	•		
Ozone	•		
TOC	•		
DNA		•	
BOD			•
Oil-in-Water			•
Protein			•
Uric Acid			•



PRODUCT NOMENCLATURE

Optan is binned by emission wavelength, between 250 nm and 280 nm, and by optical power.

Part Number ¹	Peak Wavelength			Optical output at 100mA ²	
	Min	Typical	Max	Min	Max
250 Series					
OPTAN-250J-BL	245 nm	250 nm	255 nm	1.0 mW	3.0 mW
255 Series					
OPTAN-255J-BL	250 nm	255 nm	260 nm	1.5 mW	4.0 mW
260 Series					
OPTAN-260J-BL	255 nm	260 nm	265 nm	1.0 mW	5.0 mW
275 Series³					
OPTAN-275J-BL	270 nm	275 nm	280 nm	1.0 mW	2.0 mW
OPTAN-275K-BL	270 nm	275 nm	280 nm	2.0 mW	3.0 mW
OPTAN-275L-BL	270 nm	275 nm	280 nm	3.0 mW	
280 Series (Discontinued)					
OPTAN-280K-BL	275 nm	280 nm	285 nm	2.0 mW	3.0 mW
OPTAN-280L-BL	275 nm	280 nm	285 nm	3.0 mW	

Notes:

1. LEDs are produced with semiconductor technology that is subject to process variation, yielding a range of flux performance that is approximately Gaussian in nature. To provide customers with fine granularity within the overall flux distribution, Crystal IS separates LEDs into optical power bins.
2. Output power is measured using a 100 mA current pulse of < 1 s duration at an ambient temperature of 25 °C ± 5 °C with the diode inserted into an integrating sphere.
3. Last Time Buy June 30, 2023

LED CHARACTERISTICS¹

Characteristic ¹	Unit	Min	Typical	Max
Viewing Angle ²	degrees		15	
Full width at half maximum	nm		11	
Forward voltage at 100 mA ³	V			10
Thermal resistance, junction-to-case	°C/W		20	
Power dissipation at 100 mA	W			1.0

Notes:

1. All measurements completed at an ambient temperature of 25 °C wherever applicable.
2. Viewing angle is twice of half-value angle. A half-value angle is the angle between axial direction and direction in which the light intensity value is half of the axial intensity.
3. Voltage tolerance is ±5 %.
4. L50 is the time at which light output drops to 50 % of original value during continuous operation at 25 °C.



ABSOLUTE MAXIMUM RATINGS

Characteristic ¹	Unit	Min	Max
Forward Current (continuous or CW)	mA		100
Reverse Voltage	V		-5
Operating case temperature range	°C	-5	55
Storage temperature	°C	-40	100
Junction temperature	°C		85

TYPICAL RADIATION PATTERN

Optan LEDs with a ball lens have a nominal viewing angle of 15°.

Typical Radiation Pattern

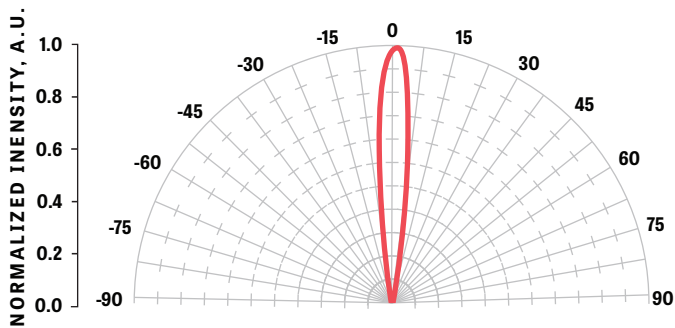

Test Conditions: I (CW) = 100 mA, CW=Continuous Wave Mode

TYPICAL ELECTRICAL CHARACTERISTICS

The typical forward voltage is less than 10V at an operating current of 100 mA.

Electrical Characteristics

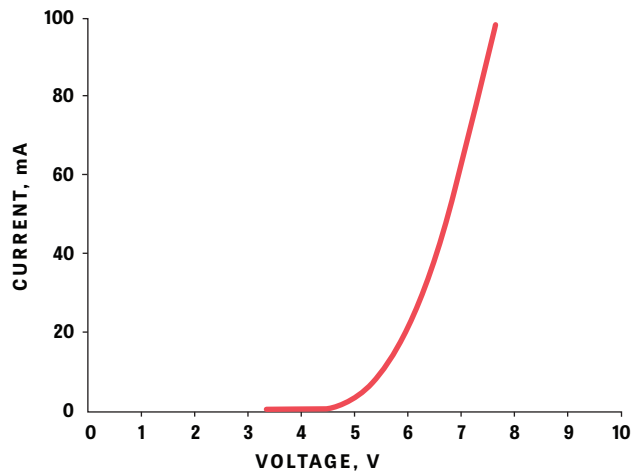

Test Conditions: I (Pulsed model)=1 to 100 mA;
Case Temperature (T_c)=25°C



TYPICAL SPECTRAL CHARACTERISTICS OVER CURRENT

The plot below illustrates the stability of the spectral characteristics with change in current. No shift is typically observed in the peak wavelength with change in driving current from 20mA to 100mA.

Spectrum vs. Current

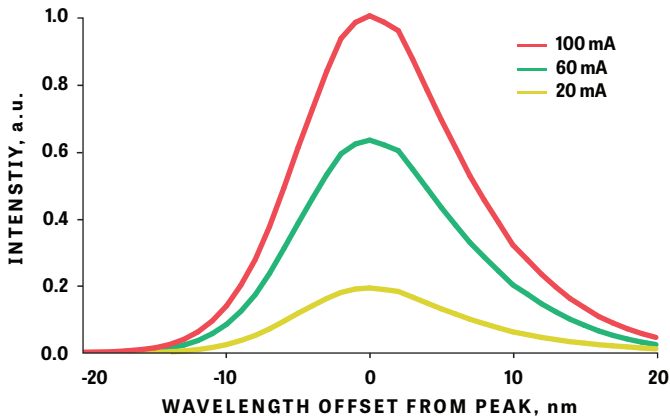

Test Conditions: Case Temperature (T_c) = 25 °C

TYPICAL LIGHT OUTPUT CHARACTERISTICS OVER CURRENT

The plot below shows the typical variation in light output with forward current. The light output data is normalized to the light output at 100 mA.

Light Output over Current

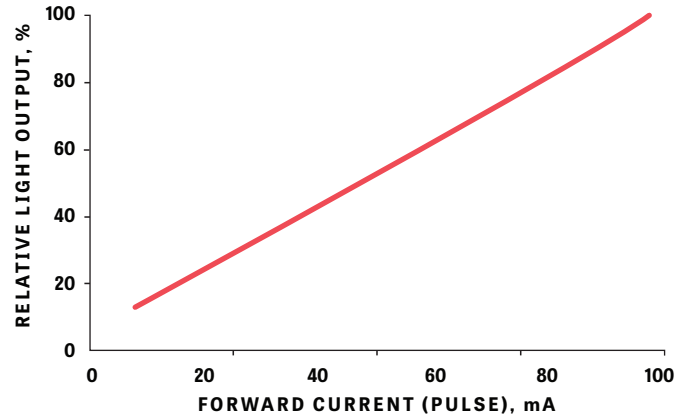

Test Conditions: Case Temperature (T_c) = 25 °C

TYPICAL SPECTRAL CHARACTERISTICS OVER TEMPERATURE

The plot below illustrates the stability of the spectral characteristics with change in temperature. No shift is typically observed in the peak wavelength with change in case temperature from 20 °C to 60 °C.

Spectrum vs. Temperature

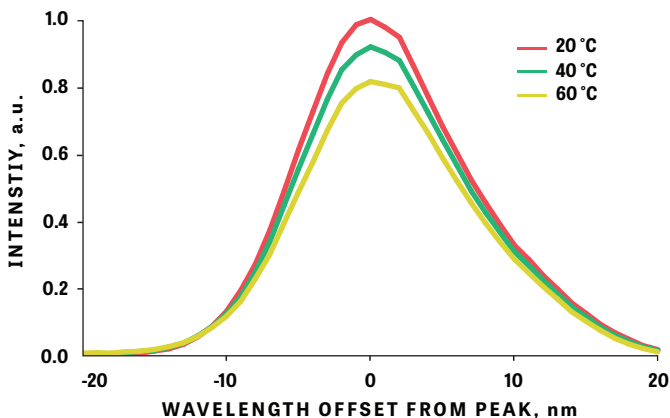

Test Conditions: I (Pulsed Mode) = 100 mA

TYPICAL LIGHT OUTPUT CHARACTERISTICS OVER TEMPERATURE

Output power is very sensitive to junction temperature, so proper thermal management techniques are suggested to control junction temperature. Lower junction temperatures will ensure the optimal performance and lifetime of the LED. The plot below shows the change in optical power with increase in junction temperature. A typical drop of 5% in light output is noticed for a 10 °C rise in temperature.

Light Output over Temperature

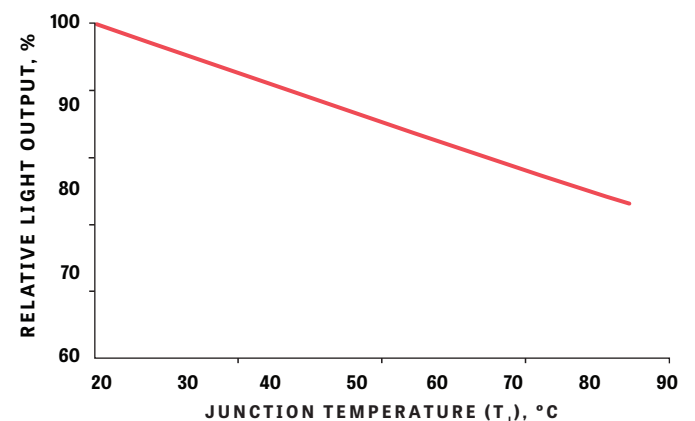

Test Conditions: I (Pulsed Mode) = 100 mA



RECOMMENDED OPERATION

Crystal IS LEDs should be operated at currents below 100 mA and mounted on a heat sink to keep the case temperature below 55 °C. Please refer to the Crystal IS thermal management note AN010 for heat sink recommendations. Circuits should be designed for constant current.

Current Derating Curve

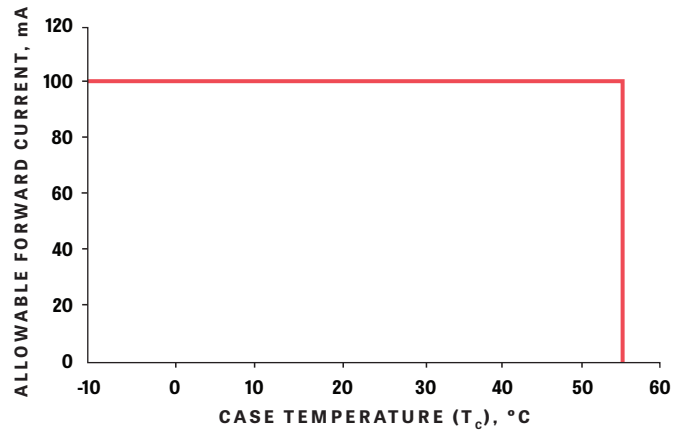

Test Conditions: CW

MECHANICAL DIMENSIONS

The Optan package is comprised of a header with a copper slug and a Kovar cap that is welded to the header to provide hermetic sealing. The cap contains a fused silica ball lens which provides the nominal viewing angle of 15°.

Optan TO-39 Package with Ball Lens

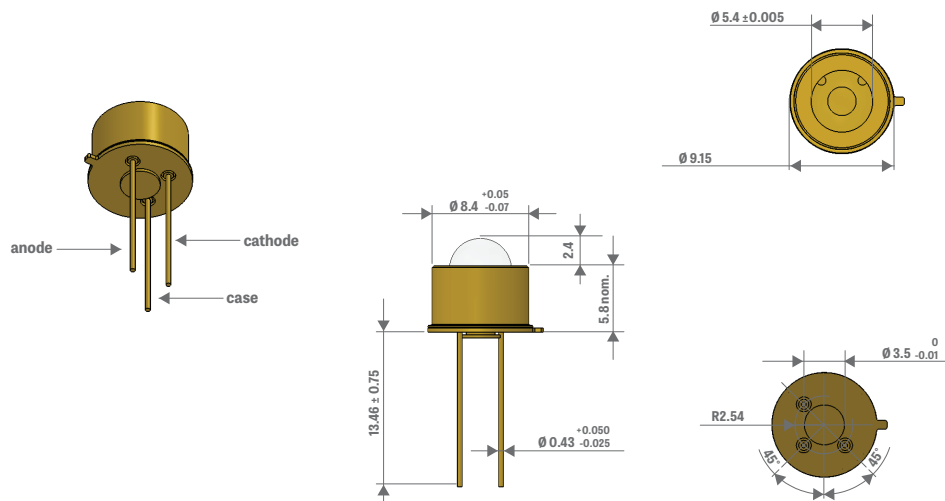

All dimensions are in millimeters. Unless noted otherwise, all dimensions have a tolerance of ± 0.05 mm.



RECOMMENDED SOLDERING GUIDELINES

1. The pitch of the LED lead should match the pitch of the mounting holes on the PCB during component placement.
2. The tip of the soldering iron should never touch the lens.
3. Recommended soldering pattern is illustrated in Figure 1. In addition, please ensure that the central copper slug in the header is thermally connected to the board with thermal paste or grease. A heat sink should be used to keep the case temperature of the LED below 55 °C at a forward current of 100 mA. Please refer to the Crystal IS thermal management note AN003 for heat sink recommendations.
4. After soldering, avoid applying external force, stress, and excessive vibration until the product has returned to ambient temperature.

RECOMMENDED SOLDERING CONDITIONS

Distance between melted solder sides to bottom of LED should be 3 mm or longer.

Parameter	Dip Soldering (Lead Free Solder)	Hand Soldering (Lead Free Solder)
Pre Heat	90 °C max. (Backside of PCB)	
Pre Heat Time	60 seconds max.	
Temperature	260 °C max. (Solder Bath)	300 °C max.
Soldering Time	5 seconds max.	3 seconds max.

RECOMMENDED CLEANING

- Cleaning with isopropyl alcohol is recommended. Propanol and ethyl alcohol may also be used.
- **DO NOT** use ultrasonic cleaners with Crystal IS LEDs.
- **DO NOT** use acetone or trichloroethylene to clean Crystal IS LEDs.

Problems with LEDs such as reduction in light output, opens, or shorts can be prevented as long as the LEDs are soldered under these conditions.

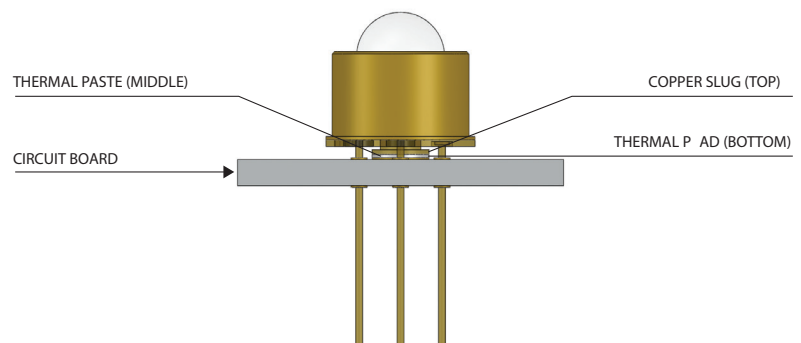

Figure 1

EYE SAFETY GUIDELINES

During operation, the LED emits high intensity ultraviolet (UV) light, which is harmful to skin and eyes. UV light is hazardous to skin and may cause cancer. Avoid exposure to UV light when LED is operational. Precautions must be taken to avoid looking directly at the UV light without the use of UV light protective glasses. Do not look directly at the front of the LED or at the LED's lens when LED is operational.

RoHS COMPLIANCE

The levels of environmentally sensitive, persistent biologically toxic (PBT), persistent organic pollutants (POP), or otherwise restricted materials in this product are below the maximum concentration values (also referred to as the threshold limits) permitted for such substances, or are used in an exempted application, in accordance with EU Directive 2015/863 on the restriction of the use of certain hazardous substances in electrical and electronic equipment (RoHS), as entered into force on July 22nd 2019.

HANDLING PRECAUTIONS

LEDs are sensitive to static electricity. When handling, proper ESD protection is required, including:

- Eliminating static charge
- Using grounded wriststrap, ESD footwear, clothes, and floors
- Grounded workstation and tools

ATTACH THE FOLLOWING WARNING LABELS ON PRODUCTS/SYSTEMS THAT USE UV LED:**DISCLAIMER**

The specifications, characteristics, and technical data presented in this datasheet are subject to change without prior notice. It is recommended that the most updated specifications, characteristics, and technical data be used in your application.

The information in this document has been compiled from reference materials and other sources believed to be reliable, and given in good faith. No warranty, either expressed or implied, is made, however, to the accuracy and completeness of the information, nor is any responsibility assumed or implied for any loss or damage resulting from inaccuracies or omissions. Each user bears full responsibility for making their own determination as to the suitability of Crystal IS products, recommendations or advice for its own particular use. Crystal IS makes no warranty or guarantee, express or implied, as to results obtained in end-use, nor of any design incorporating its Products, recommendation or advice. Each user must identify and perform all tests and analyses necessary to ensure that its finished application incorporating Crystal IS' products will be safe and suitable for use under end-use conditions. Each user of devices assumes full responsibility to become educated in and to protect from harmful irradiation. Crystal IS specifically disclaims any and all liability for harm arising from buyer's use or misuse of UVC devices either in development or end-use.

Crystal IS, Inc.,
an Asahi Kasei Company

70 Cohoes Avenue
Green Island, NY 12183
U.S.A.

sales@cisuv.com
(518) 271-7375
www.cisuv.com

© 2023 Crystal IS, Inc. All rights reserved.
Crystal IS, Optan and the Crystal IS logo
are trademarks of Crystal IS, Inc. and/or
its affiliates. All other trademarks are the
property of their respective owners.
1066-1811