

22ECP35 Ultra EC™

Ø 22 mm • 2-pole • 55 W

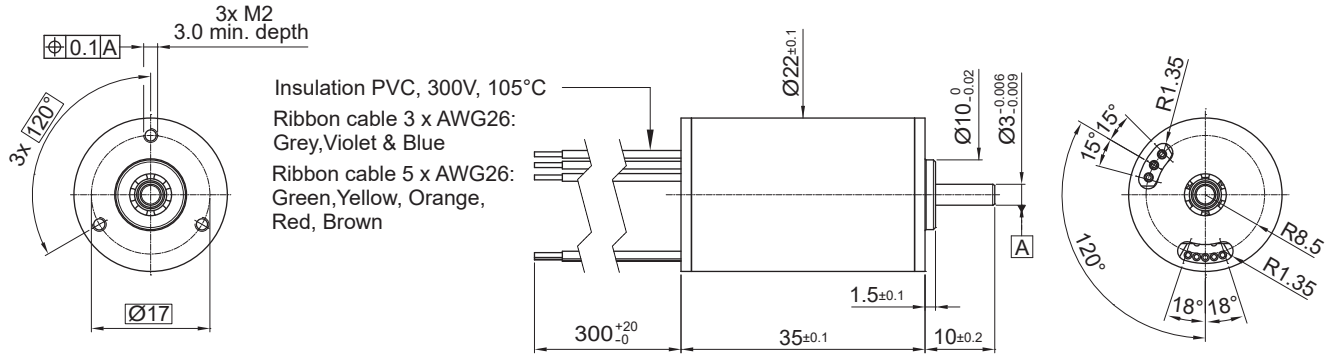

Dimensions in mm

Electrical Data	Symbol	22ECP35 8B-184.01	Unit
1 Nominal Voltage	$U_N$	24	Volt
2 Optimization Direction	-	Symmetrical	-
3 No Load Speed	$n_0$	13,200	rpm
4 Typical No Load Current	$I_0$	30.0	mA
5 Max. Continuous Mechanical Power (@25°C)	$P_{max}$	56.0	W
6 Max. Continuous Current	$I_{e,max}$	0.8	A
7 Max. Continuous Torque	$M_{e,max}$	14.3 (2.03)	mNm (oz-in)
8 Back EMF Constant	$k_E$	1.82	V/1000 rpm
9 Torque Constant	$k_M$	17.4	mNm/A
10 Motor Regulation	$R/k^2$	21.8	10 <sup>3</sup> /Nms
11 Motor Regulation	$k/R^{1/2}$	6.77 (0.96)	mNm/W <sup>1/2</sup> (oz-in/W <sup>1/2</sup> )
12 Internal Resistance - phase to phase	$R_l$	6.58	ohms
13 Line to Line Resistance at Connectors	$R_L$	6.71	ohms
14 Inductance Phase to Phase	$L$	0.89	mH
15 Mechanical Time Constant	$\tau_m$	3.0	ms
16 Electrical Time Constant	$\tau_e$	0.14	ms

General Data			
17 Maximum Motor Speed	$n_{max}$	50000	rpm
18 Ambient Working Temperature Range	-	-30 to +100 (-22 to +212)	°C (°F)
19 Ambient Storage Temperature Range	-	-40 to +100 (-40 to +212)	°C (°F)
20 Ball Bearings Preload	-	5.50	N
21 Axial Static Force w/o Shaft Support (max)	-	34.00	N
22 Maximum Winding Temperature	-	125 (257)	°C (°F)
23 Thermal Resistance	$R_{th}$	3.5/12.5	°C/W
24 Thermal Time Constant	$\tau_w$	550	s
25 Weight	-	64 (2.26)	g (oz)
26 Rotor Inertia	$J$	1.38	g-cm <sup>2</sup>
27 Hall Sensor Electrical Phasing*	-	120.00	Electrical °

\*Also available without Hall sensors

Wire	Description
Gray	Phase 1
Violet	Phase 2
Blue	Phase 3
Green	3.5 to 24V DC
Yellow	GND
Orange	Sensor 1
Red	Sensor 2
Brown	Sensor 3

with hall effect sensor

