

REVISIONS				
REV.	ECN	DESCRIPTION	DATE	APPROVED
A		PROPOSAL	FEB 06/19	J. SI
-		-	-	-

AMPHENOL PART NUMBER CONFIGURATION
UE86-4G8620-X0X61

- LIGHT PIPE OPTION**
 0 - NO LIGHT PIPE
 1 - 4 LP PER 2X1, NORMAL ORIENTATION
 2 - 2 INNER LP PER 2X1, NORMAL ORIENTATION
 3 - 2 OUTER LP PER 2X1, NORMAL ORIENTATION
 4 - 4 LP PER 2X1, REVERSING ORIENTATION
 5 - 2 INNER LP PER 2X1, REVERSING ORIENTATION
 6 - 2 OUTER LP PER 2X1, REVERSING ORIENTATION
 7 - 3 LP PER 2X1, 2 OUTER LP, NORMAL ORIENTATION
 8 - 3 LP PER 2X1, 2 OUTER LP, REVERSING ORIENTATION

- PACKAGING**
 1 - TRAY PACKAGING (STACKED)
- PLATING OPTIONS FOR CONNECTOR**
 2 - 30µ" GOLD PLATING ON MATING AREA
 15-100µ" MATTE TIN ON TERMINATION
 3 - 30µ" GOLD PLATING ON MATING AREA
 150-300µ" MATTE TIN ON TERMINATION
 5 - 15µ" GOLD PLATING ON MATING AREA
 15-100µ" MATTE TIN ON TERMINATION
 6 - 15µ" GOLD PLATING ON MATING AREA
 150-300µ" MATTE TIN ON TERMINATION

PART NUMBER
 (LAST DIGIT INDICATING
 PACKAGING TYPE, NOT
 PRINTED ON THE PART)

DATE CODE

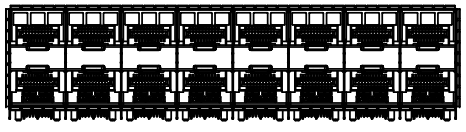
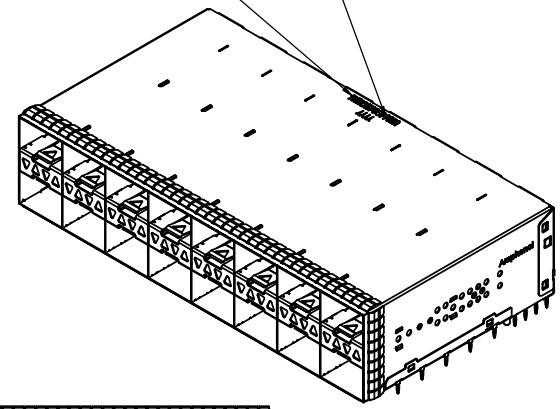

NO LIGHT PIPES
 UE86-4G8620-00X61

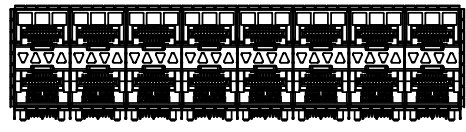

4 LIGHT PIPES
 UE86-4G8620-10X61

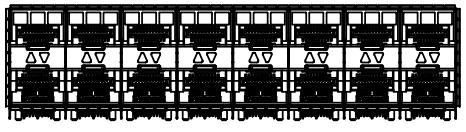

2 INNER LIGHT PIPES
 UE86-4G8620-20X61



2 OUTER LIGHT PIPES
 UE86-4G8620-30X61

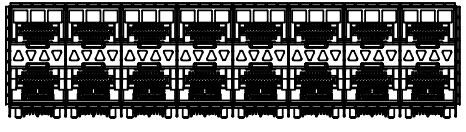

4 LIGHT PIPES UPSIDE DOWN
 UE86-4G8620-40X61

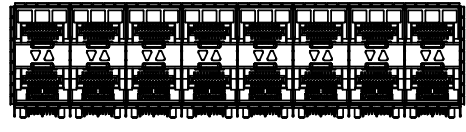

2 INNER LIGHT PIPES UPSIDE DOWN
 UE86-4G8620-50X61

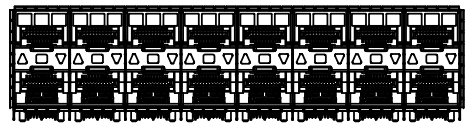

3 LIGHT PIPES UPSIDE DOWN
 UE86-4G8620-80X61

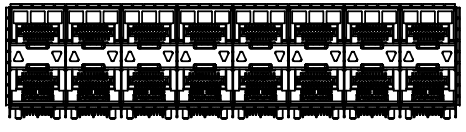

2 OUTER LIGHT PIPES UPSIDE DOWN
 UE86-4G8620-60X61

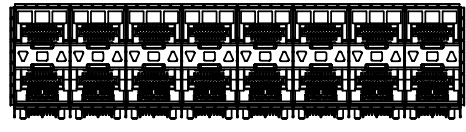

3 LIGHT PIPES
 UE86-4G8620-70X61



MATERIAL: (RoHS COMPLIANT)

- CAGE - PRESS FIT: COPPER ALLOY (NICKEL SILVER)
- CONNECTOR - PRESS FIT:
 - PLASTIC HOUSING: LCP, FLAMMABILITY RATING UL94-V0
 - CONTACTS: PHOSPHOR BRONZE
- LIGHT PIPE: CLEAR POLYCARBONATE, FLAMMABILITY RATING UL94-V0
- PACKAGING: TRAY PACKAGING
- TEMPERATURE RANGE: -40°C TO +85°C

THIS DOCUMENT CONTAINS PROPRIETARY INFORMATION AND SUCH INFORMATION MAY NOT BE DISCLOSED TO OTHERS FOR ANY PURPOSE OR USED FOR MANUFACTURING PURPOSES WITHOUT WRITTEN PERMISSION FROM AMPHENOL CANADA CORP.

UNLESS SPECIFIED OTHERWISE	DRAWN	P. TOMA	FEB 06/19	Amphenol High Speed Interconnects A Division of Amphenol Corp. www.amphenolcanada.com 2X8 SFP EXTREMEPORT WITH LIGHT PIPE OPTIONS AND EMI SPRING FINGER DWG. NO. P-UE86-4G8620-X0X61 REF. ECN Exxxxx	REV
DIMENSIONS ARE IN MILLIMETERS	CHECKED	J. SI	FEB 06/19		A
REFERENCE IN PARENTHESES	M.E. APP'D				
GENERAL TOLERANCES	Q.A. APP'D				
1 DECIMAL PLACE ±0.25	DWG APP'D	J. SI	FEB 06/19		
2 DECIMAL PLACE ±0.15	MATERIAL AND FINISH	SEE NOTES			
3 DECIMAL PLACE N/A	REF.				
ANGULAR DEGREES ±1°	THIRD ANGLE PROJECTION				
ENG. REL. NO.					
				DO NOT SCALE DRAWING	
				CODE ID NO. 03554 DWG SIZE: A4 SCALE: 3:5 SHEET 1 OF 5	

1 2 3 4 5 6

REVISIONS				
REV.	ECN	DESCRIPTION	DATE	APPROVED
A		PROPOSAL	FEB 06/19	J. SI
-		-	-	-

A

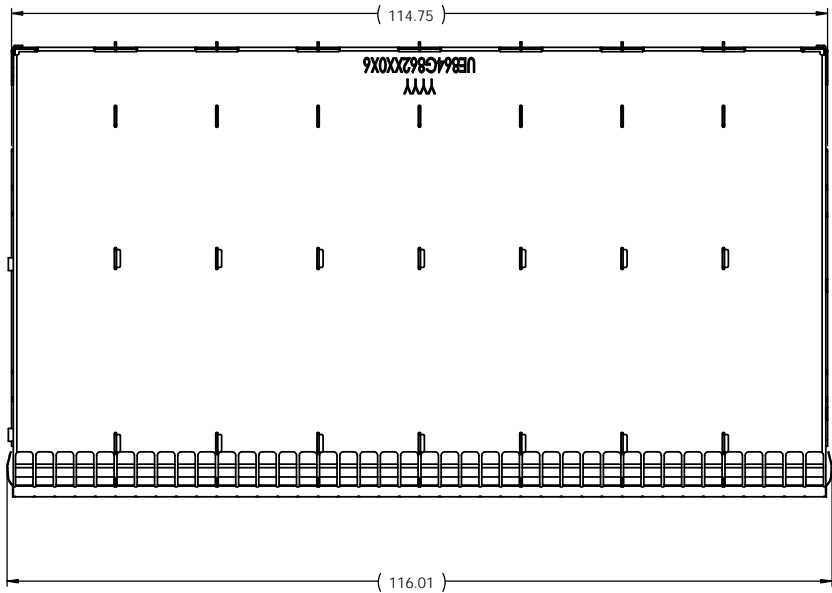

B

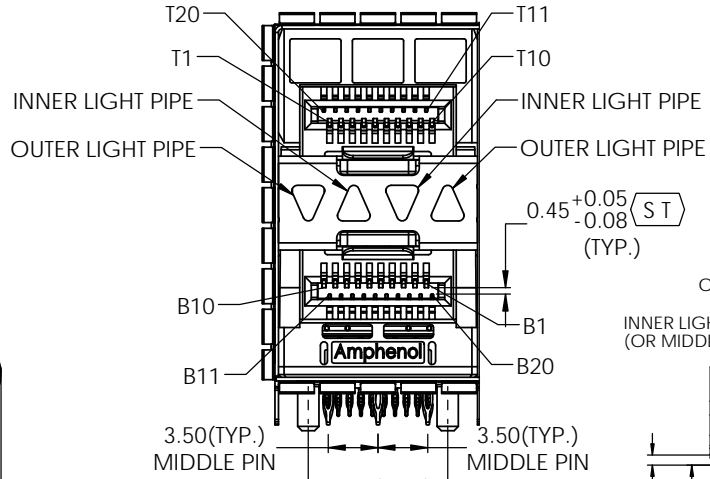

DETAIL A
SCALE 2 : 1

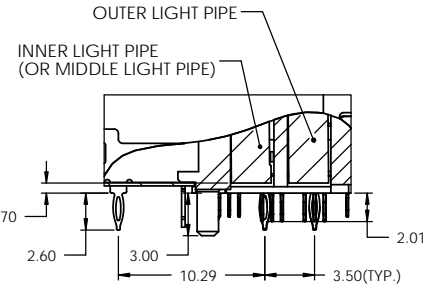

DETAIL B
SCALE 2 : 1

C

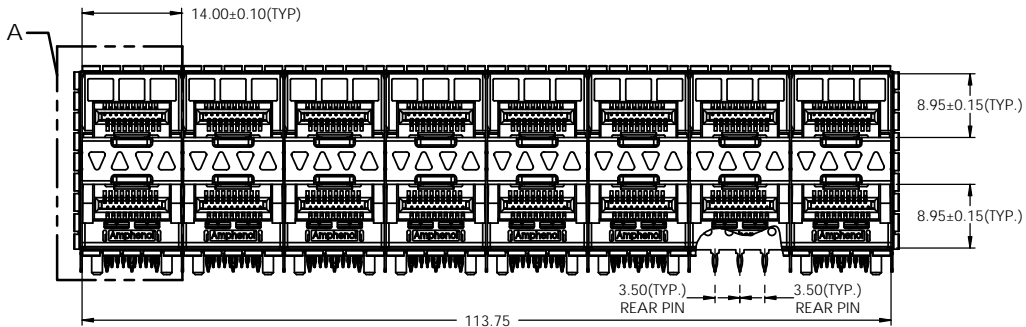

D

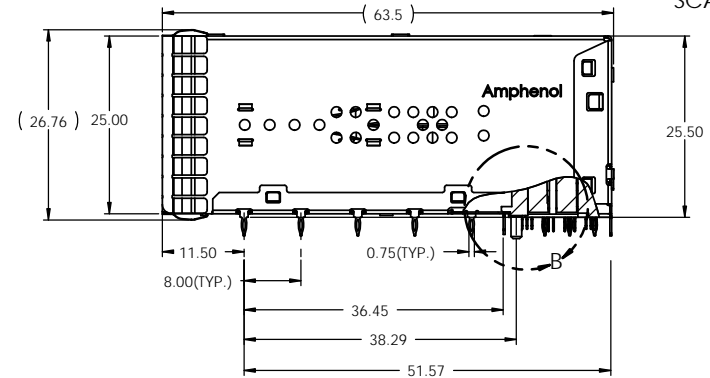

THIS DOCUMENT CONTAINS PROPRIETARY INFORMATION AND SUCH INFORMATION MAY NOT BE DISCLOSED TO OTHERS FOR ANY PURPOSE OR USED FOR MANUFACTURING PURPOSES WITHOUT WRITTEN PERMISSION FROM AMPHENOL CANADA CORP.

UNLESS SPECIFIED OTHERWISE	DRAWN	P. TOMA	FEB 06/19
DIMENSIONS ARE IN MILLIMETERS	CHECKED	J. SI	FEB 06/19
REFERENCE IN PARENTHESES	M.E. APP'D		
GENERAL TOLERANCES	Q.A. APP'D		
1 DECIMAL PLACE ±0.25	DWG APP'D	J. SI	FEB 06/19
2 DECIMAL PLACE ±0.15	MATERIAL AND FINISH	SEE NOTES	
3 DECIMAL PLACE N/A	REF.	ECN EXXXX	
ANGULAR DEGREES ±1°	THIRD ANGLE PROJECTION		
ENG. REL. NO.	DO NOT SCALE DRAWING		

Amphenol High Speed Interconnects
A Division of Amphenol Corp. www.amphenolcanada.com

**2X8 SFP EXTREMEPORT WITH LIGHT PIPE
OPTIONS AND EMI SPRING FINGER**

DWG. NO.	P-UE86-4G8620-XOX61	REV	A
CODE ID NO.	03554	DWG SIZE:	A4
SCALE:	1:1	SHEET	2 OF 5

1 2 3

REVISIONS				
REV.	ECN	DESCRIPTION	DATE	APPROVED
A		PROPOSAL	FEB 06/19	J. SI
-		-	-	-

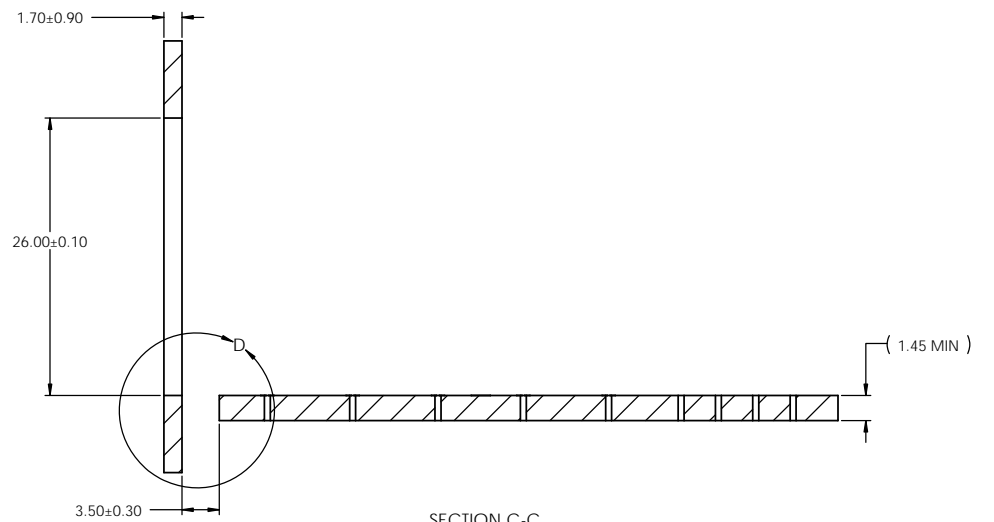
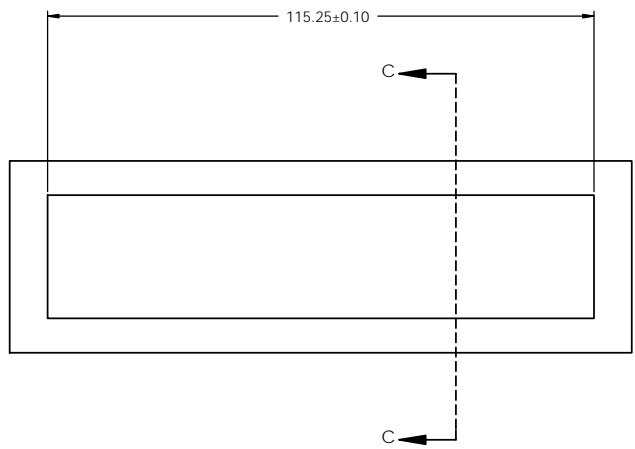

SECTION C-C
SCALE 3 : 2

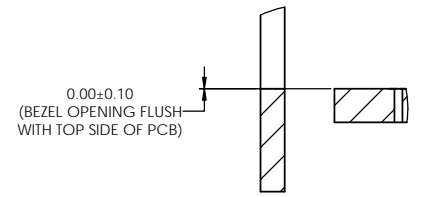
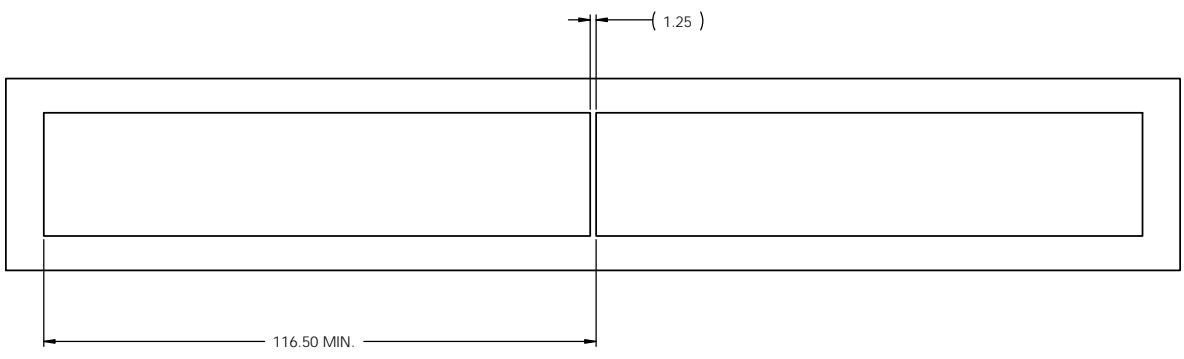

DETAIL D
SCALE 2 : 1

THIS DOCUMENT CONTAINS PROPRIETARY INFORMATION AND SUCH INFORMATION MAY NOT BE DISCLOSED TO OTHERS FOR ANY PURPOSE OR USED FOR MANUFACTURING PURPOSES WITHOUT WRITTEN PERMISSION FROM AMPHENOL CANADA CORP.

UNLESS SPECIFIED OTHERWISE		DRAWN P. TOMA FEB 06/19		Amphenol High Speed Interconnects A Division of Amphenol Corp. www.amphenolcanada.com	
DIMENSIONS ARE IN MILLIMETERS		CHECKED J. SI FEB 06/19			
REFERENCE IN PARENTHESES		M.E. APP'D		2X8 SFP EXTREMEPORT WITH LIGHT PIPE OPTIONS AND EMI SPRING FINGER	
GENERAL TOLERANCES		Q.A. APP'D			
1 DECIMAL PLACE ±0.25		DWG APP'D J. SI FEB 06/19			
2 DECIMAL PLACE ±0.15		MATERIAL AND FINISH SEE NOTES		DWG. NO. P-UE86-4G8620-X0X61	
3 DECIMAL PLACE N/A		REF. ECN Exxxxx		REV A	
ANGULAR DEGREES ±1°		THIRD ANGLE PROJECTION		CODE ID NO. 03554 DWG SIZE: A4 SCALE: 1:1 SHEET 3 OF 5	
ENG. REL. NO.		DO NOT SCALE DRAWING			

REVISIONS				
REV.	ECN	DESCRIPTION	DATE	APPROVED
A		PROPOSAL	FEB 06/19	J. SI
-		-	-	-

NOTES:
 1. 0.56 mm DIAMETER HOLES ARE CHASSIS GROUND (129HOLES).

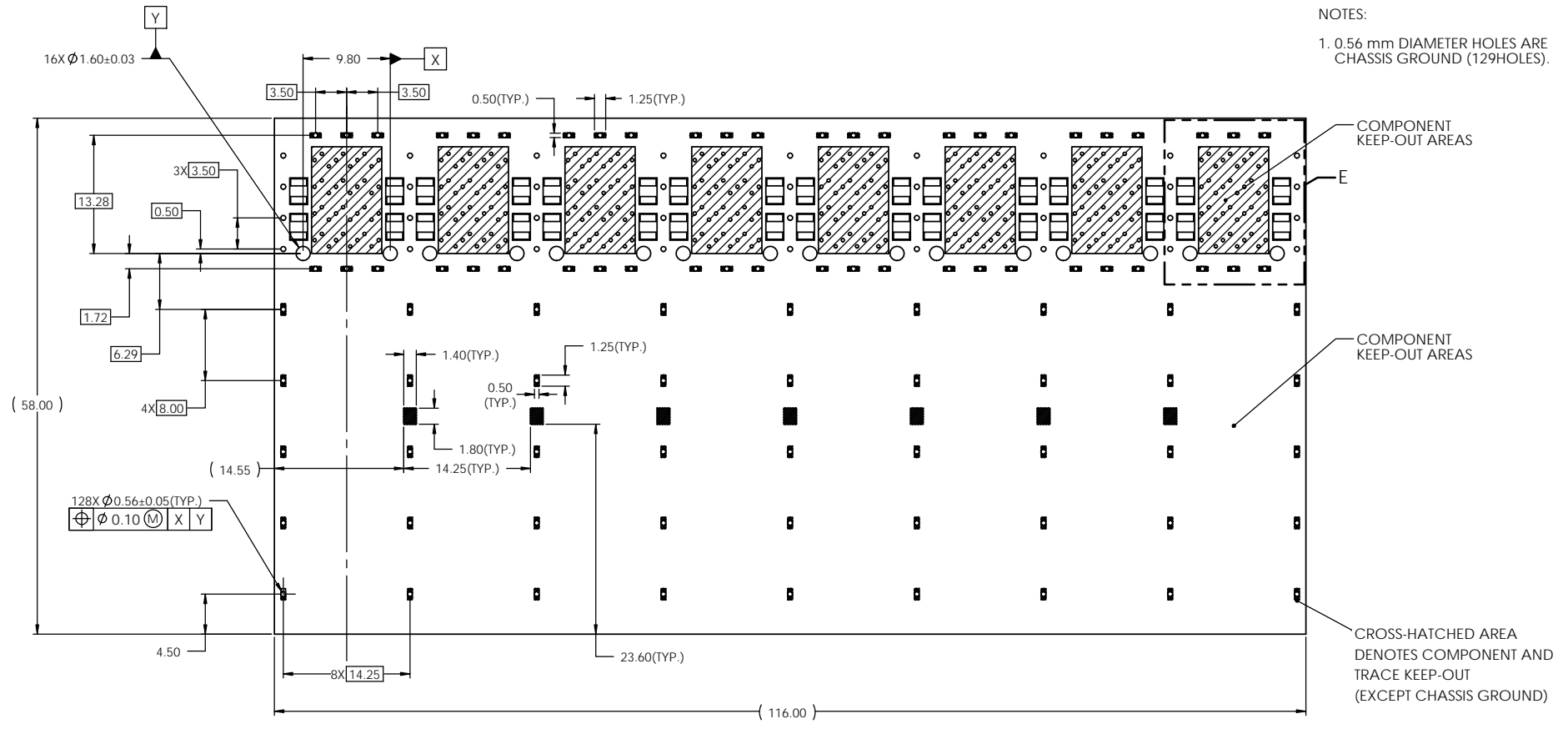

2X8 PCB LAYOUT

THIS DOCUMENT CONTAINS PROPRIETARY INFORMATION AND SUCH INFORMATION MAY NOT BE DISCLOSED TO OTHERS FOR ANY PURPOSE OR USED FOR MANUFACTURING PURPOSES WITHOUT WRITTEN PERMISSION FROM AMPHENOL CANADA CORP.

UNLESS SPECIFIED OTHERWISE DIMENSIONS ARE IN MILLIMETERS REFERENCE IN PARENTHESES GENERAL TOLERANCES 1 DECIMAL PLACE ±0.25 2 DECIMAL PLACE ±0.15 3 DECIMAL PLACE N/A ANGULAR DEGREES ±1° ENG. REL. NO.	DRAWN	P. TOMA	FEB 06/19	Amphenol High Speed Interconnects A Division of Amphenol Corp. www.amphenolcanada.com 2X8 SFP EXTREMEPORT WITH LIGHT PIPE OPTIONS AND EMI SPRING FINGER	DWG. NO. P-UE86-4G8620-XOX61 REV A
	CHECKED	J. SI	FEB 06/19		
	M.E. APP'D				
	Q.A. APP'D				
	DWG APP'D	J. SI	FEB 06/19		
	MATERIAL AND FINISH	SEE NOTES			
	REF.	ECN Exxxxx			
	THIRD ANGLE PROJECTION			DO NOT SCALE DRAWING	
		CODE ID NO.	03554	DWG SIZE:	A4
		SCALE:	2:1	SHEET	4 OF 5

REVISIONS				
REV.	ECN	DESCRIPTION	DATE	APPROVED
A		PROPOSAL	FEB 06/19	J. SI
-		-	-	-

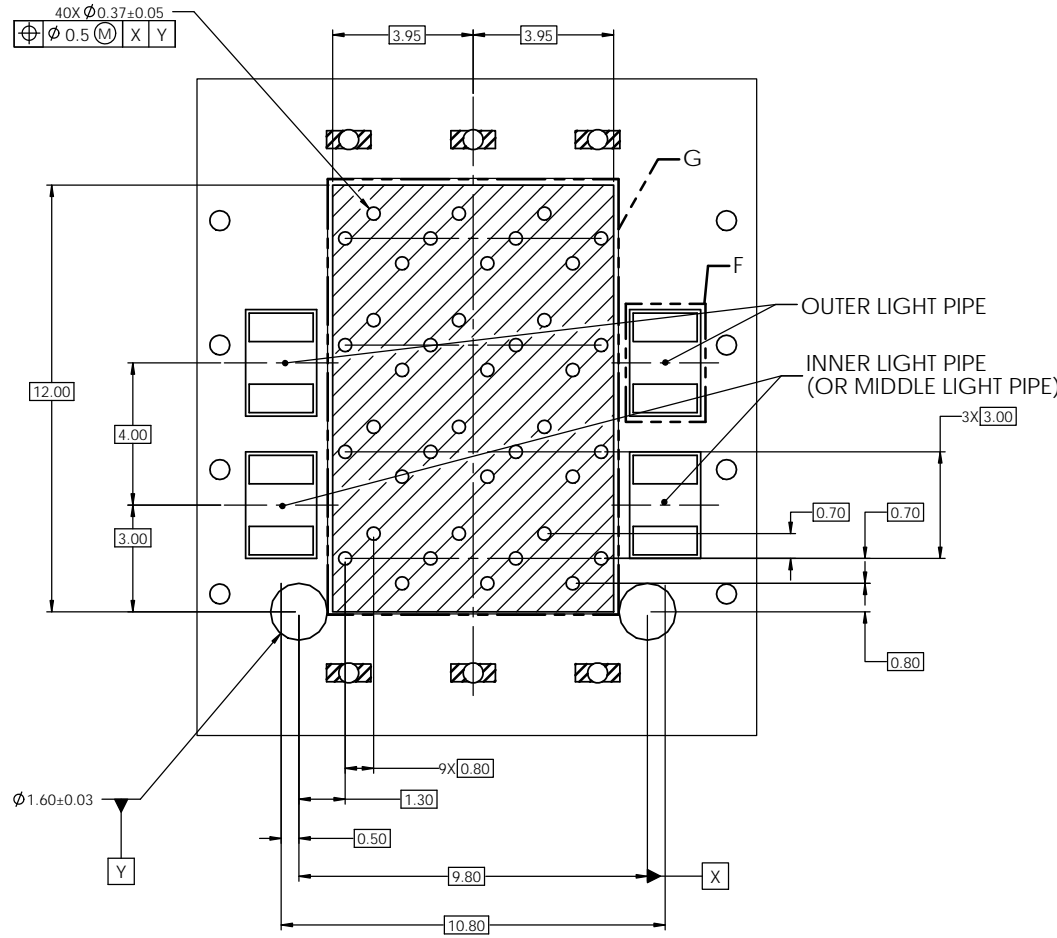

DETAIL E
SCALE 5 : 1

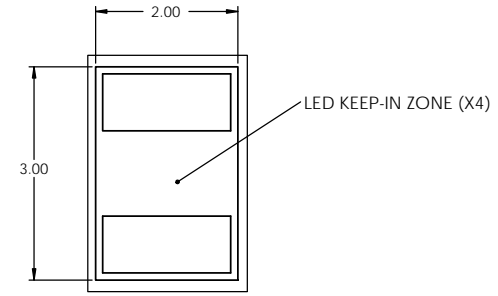

DETAIL F
SCALE 10 : 1

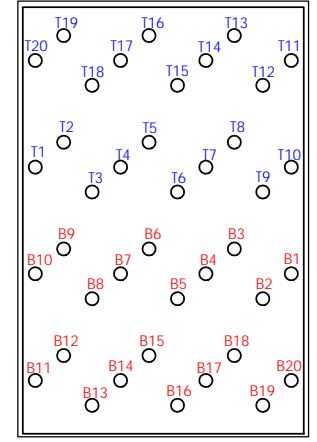

DETAIL G
SCALE 5 : 1

THIS DOCUMENT CONTAINS PROPRIETARY INFORMATION AND SUCH INFORMATION MAY NOT BE DISCLOSED TO OTHERS FOR ANY PURPOSE OR USED FOR MANUFACTURING PURPOSES WITHOUT WRITTEN PERMISSION FROM AMPHENOL CANADA CORP.

UNLESS SPECIFIED OTHERWISE DIMENSIONS ARE IN MILLIMETERS		DRAWN	P. TOMA	FEB 06/19	Amphenol High Speed Interconnects A Division of Amphenol Corp. www.amphenolcanada.com 2X8 SFP EXTREMEPORT WITH LIGHT PIPE OPTIONS AND EMI SPRING FINGER
REFERENCE IN PARENTHESES		CHECKED	J. SI	FEB 06/19	
GENERAL TOLERANCES		M.E. APP'D			
1 DECIMAL PLACE ±0.25		Q.A. APP'D			
2 DECIMAL PLACE ±0.15		DWG APP'D	J. SI	FEB 06/19	
3 DECIMAL PLACE N/A		MATERIAL AND FINISH	SEE NOTES		
ANGULAR DEGREES ±1°		REF.	ECN Exxxxx		
ENG. REL. NO.		THIRD ANGLE PROJECTION	DO NOT SCALE DRAWING		DWG. NO.
					P-UE86-4G8620-X0X61
					REV A
					CODE ID NO. 03554 DWG SIZE: A4 SCALE: 2:1 SHEET 5 OF 5