



WEPS06 Series



- Up to 2500 feet line-of-site range
- Pressure ranges up to 6000 PSI gauge
- Piezo-resistive thick film ceramic sensor with stainless steel body.
- Five year battery life at 10 second transmission update rate
- User-selectable transmission update rates
- User-selectable 1-5V or 4-20mA receiver outputs
- Simple DIL switch pairing with the single channel receiver
- Relay Contacts provided for alarm functions

DESCRIPTION

The WEPS06 Wireless Pressure Transducer is a cost effective replacement to a traditionally wired pressure transducer that offers the advantages of a low-cost installation in inaccessible and expensive installation environments. It is easily paired to the compatible PS6W-1 family of single- or five-channel wireless receivers thus offering a “plug and play” solution to your pressure measurement applications. The instrument uses a piezo-resistive ceramic sensor mounted within a stainless steel housing giving excellent media compatibility for the harshest of applications. A swivel adaptor is available which allows the head to be easily aligned to the PS6W-1 receiver. A line-of-sight range of up to 2500 feet is possible depending on the wireless receiver used (refer to datasheets PS6W-1-1 & PS6W-1-5 for further information). Each device is temperature compensated, calibrated and supplied with a traceable serial number.

APPLICATIONS

- Consumer products
- Agriculture
- HVAC
- Pool Pumps
- Compressor
- Pneumatics
- Temporary Service Trials

Maximum Environmental Ratings

Operating Temperature -20°C to 85°C
 Media Temperature Range-20°C to 125°C

Proof pressure 2x full scale pressure
 Burst pressure 2.5x full scale pressure (Max 9kPSI)

Agricultural Equipment

The WEPS06 is a wireless pressure sensor used in a variety of liquid level applications, such as Water Trucks, Liquid Tanks, Oil tanks, and Spas.



Natural Gas Pipe Equipment



The WEPS06 is a wireless pressure sensor that can measure up to pressures of 6000 PSI. It is accurate and robust enough for HVAC applications; if you need temporary remote pressure measurement of the system this sensor is your solution.

Oil/Gas Industry

The WEPS06 is a wireless pressure sensor that can measure down to pressures of 15PSI, so it is ideal for most air filter applications. For troubleshooting, the WEPS06 offers temporary remote pressure measurement of the system. The battery powered solution can last up to five years of continuous (1 measurement/10 seconds) use.



Pumps – Water, Hydraulic, etc.



The WEPS06 is a wireless pressure sensor that can measure up to pressures of 6000 PSI, so it is ideal for hydraulic pump applications. For monitoring, the WEPS06 offers temporary remote pressure measurement of the system. The battery powered solution can last up to 5 years of continuous (1 measurement/10 seconds) use.

WEPS06 Operational Characteristics

V ₊ = 5V, V ₋ = 0V, Temperature = 25°C					
PARAMETER	SYMBOL	MIN	TYP	MAX	UNITS
Supply Voltage (Lithium C Cell)	V _{DD}	2.2	3	3.5	V
Supply Current	I _{DD}	5	50	750	uA
Wireless Digital Output			2.4		GHz
Linearity (Note 1)		-0.25		0.25	%FS
Temperature Error (Null and Span) (Note 3)		-0.07		+0.07	%FS/°C
Response Time	t _R	1	5	30	Seconds
Total Error Band (Note 4)		-1		1	%FS
Media Temperature Range	C	-20		125	°C
Operating Temperature Range	C	-20		85	°C

Notes:

1) Defined as best straight line 4) Measured over compensated temperature range -10-50C

Application Information

Package

The body design is made of SS316, which allows for easy low-cost manufacturability and corrosion resistance. Vibration proof design for use in industrial applications.

Stability

The silicon MEMS pressure sensor element is mounted to a ceramic base and sealed into the SS316 housing. The selection of thermally capability materials reduce the mechanical stress on the sensor resulting in greater stability over time and temperature.

Additional stability is gained from factory stabilization of all sensors.

Pressure port

1/4" -18NPT thread is the standard SS fittings. Other port fittings such as 7/16-20UNF, and 1/4" BSP are available for OEM customers.

Media

The pressure port is tolerant to most media including but not limited to oil, air, gas, and non-corrosive media. Sensor will only work on a temporary basis in any non-air application. Sensor will need to have a period of time to dehydrate.

Wetted parts

When checking media capability, the wetted surface is composed of 316 SS and Viton.

Pressure ranges

Standard pressure ranges are 15, 30, 75, 150, 300, 750, 1500, 3500, and 6000 psi in gauge.

Mechanical Dimensions (mm)

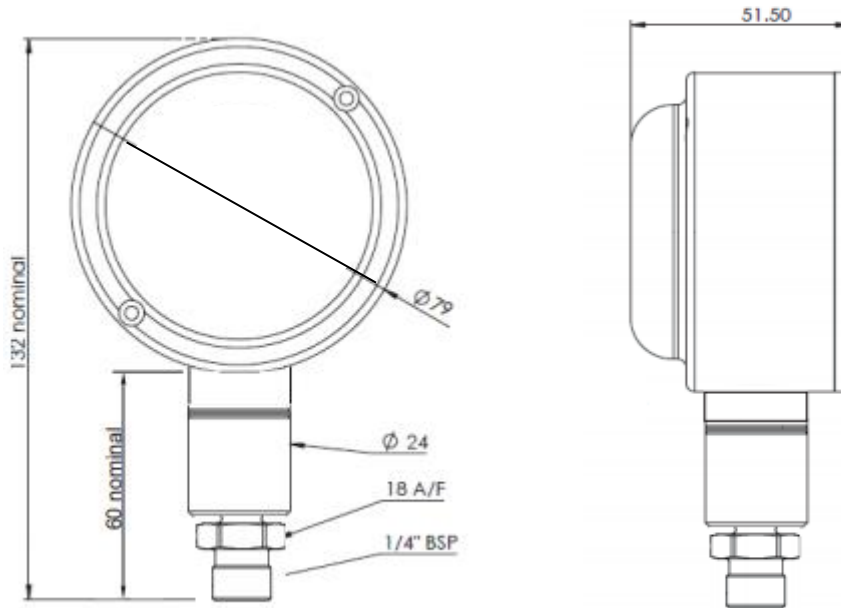

Part Number Configuration

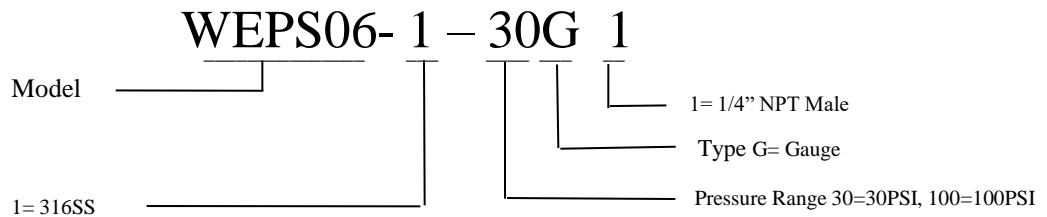

Standard Part Numbers

Part Number	Pressure Rating	Receiver Output
WEPS06-1-30G1	0-30 PSI	1-5Vdc or 4-20mA
WEPS06-1-150G1	-14.5 to +150 PSI	1-5Vdc or 4-20mA
WEPS06-1-300G1	0-300 PSI	1-5Vdc or 4-20mA
WEPS06-1-3K6G1	0-3600 PSI	1-5Vdc or 4-20mA

Notice:

Phoenix Sensors LLC reserves the right to make changes to the product contained in this publication. Phoenix Sensors LLC assumes no responsibility for the use of any circuits described herein, conveys no license under any patent or other right, and makes no representation that the circuits are free of patent infringement. While the information in this publication has been checked, no responsibility, however, is assumed for inaccuracies.

Phoenix Sensors LLC does not recommend the use of any of its products in life support applications where the failure or malfunction of the product can reasonably be expected to cause failure of a life-support system or to significantly affect its safety or effectiveness. Products are not authorized for use in such applications.

Ph: (480) 462-1810 sales@PhoenixSensors.com