



Indoor DAS Ceiling Omni Antenna, 5 dBi, 617 MHz
- 6000 MHz, 4 x 4.3-10 Female, Low PIM

Antennas Technical Data Sheet

PE51242

Features

- Indoor distribution of 5G, LTE, GSM/CDMA
- In-building public or private networks
- LPWAN, LoRA, LTE-M, NB-IoT, IoT, M2M applications
- DAS (Distributed Antenna Systems)

Applications

- Low Passive Intermodulation (PIM) <-153 dBc @ 2x20W
- Vertical Polarization
- Low return loss, stable performance
- 4 x 4.3-10 Female connector for long lasting consistent results
- Covers all sub 6 GHz 5G frequency bands including 600 MHz and extended CBRS
- 360 degree omnidirectional pattern

Description

Pasternack's Indoor DAS Ceiling Omni Antenna PE51242 is in stock and ready to ship the same-day of order. The PE51242 indoor ceiling omni antenna comes with 6dBi gain and 4 x 4.3-10 female connectors. This indoor DAS ceiling omni antenna has a wide band frequency range from 617MHz to 6000MHz. The 4 port capabilities increase the 5G data speeds up to 4 x that of a single antenna. Pasternack's Low PIM (low internal noise) 4x4.3-10 female increases the throughput, data speeds, quality of connection and allows more users to connect to the antenna.

Our omni antenna specialists are ready and available to answer any questions you may have on the PE51242 indoor DAS ceiling omni antenna. The 6dBi ceiling omni antenna low profile designs allow for seamless installation indoors without creating eyesores or potential interference with indoor personnel. These low PIM antennas have low loss pigtailed that allows for installation flexibility.

Contact Pasternack's expert technical support for assistance with the indoor DAS ceiling omni antenna or any Antenna. Our knowledgeable sales team simplifies the purchasing process and ensures that your ceiling Omni antenna will be exact to specification.

The omni antenna PE51242 from Pasternack provides a higher quality connection and improved longevity. Order your 4-port low PIM (low noise) Indoor DAS Ceiling Omni Antenna PE51242 from Pasternack today. There is no MOQ (minimum order quantity) and the product ships same day from our warehouse.

Configuration

Design	Ceiling
Band Type	Wide
Radiation Pattern	Omnidirectional
Polarization	Horizontal
Connector Type	4.3-10 Female
Interface 2	4.3-10 Female
Interface 3	4.3-10 Female
Interface 4	4.3-10 Female
Number of Ports	4

Electrical Specifications

Description	Minimum	Typical	Maximum	Units
Frequency Range	617		6,000	MHz
Input VSWR			1.8:1	

Click the following link (or enter part number in "SEARCH" on website) to obtain additional part information including price, inventory and certifications: [Indoor DAS Ceiling Omni Antenna, 5 dBi, 617 MHz - 6000 MHz, 4 x 4.3-10 Female, Low PIM PE51242](#)



Indoor DAS Ceiling Omni Antenna, 5 dBi, 617 MHz
- 6000 MHz, 4 x 4.3-10 Female, Low PIM

Antennas Technical Data Sheet

PE51242

Impedance	50	Ohms
Gain	3	4.5 dBi
Input Power	50	Watts
Passive Intermodulation 3rd order, 2 x 20 W	-153	dBc

Specifications by Band

Description	Band 1	Band 2	Band 3	Band 4	Band 5	Units
Range	0.617 to 0.698	0.698 to 0.96	1.695 to 2.7	3.3 to 4	4.8 to 6	GHz
Gain	3	3	4.5	4.5	4.5	dBi
Port to Port Isolation	17	17	20	30	30	dB
Horizontal Beam Width	360	360	360	360	360	Degrees
Vertical Beam Width	360	360	360	360	360	Degrees
VSWR Max	1.8:1	1.8:1	1.8:1	1.8:1	1.8:1	

Mechanical Specifications

Radome Material	ABS
Size	
Overall Length	14.1732 in [360 mm]
Width	14.1732 in [360 mm]
Height	0.944882 in [24 mm]
Weight	10.46 lbs [4.74 kg]

Environmental Specifications

Temperature	
Operating Range	-55 to +60 deg C
Humidity	<95

Compliance Certifications (see [product page](#) for current document)

Plotted and Other Data

Notes:

Click the following link (or enter part number in "SEARCH" on website) to obtain additional part information including price, inventory and certifications: [Indoor DAS Ceiling Omni Antenna, 5 dBi, 617 MHz - 6000 MHz, 4 x 4.3-10 Female, Low PIM PE51242](#)



Indoor DAS Ceiling Omni Antenna, 5 dBi, 617 MHz
- 6000 MHz, 4 x 4.3-10 Female, Low PIM

Antennas Technical Data Sheet

PE51242

Indoor DAS Ceiling Omni Antenna, 5 dBi, 617 MHz - 6000 MHz, 4 x 4.3-10 Female, Low PIM from Pasternack Enterprises has same day shipment for domestic and International orders. Our RF, microwave and millimeter wave products maintain a 99.4% availability and are part of the broadest selection in the industry.

Click the following link (or enter part number in "SEARCH" on website) to obtain additional part information including price, inventory and certifications: [Indoor DAS Ceiling Omni Antenna, 5 dBi, 617 MHz - 6000 MHz, 4 x 4.3-10 Female, Low PIM PE51242](https://www.pasternack.com/6-dbi-wide-band-ceiling-antenna-617-6000-mhz-4.3-10-female-connector-pe51242-p.aspx)

URL: <https://www.pasternack.com/6-dbi-wide-band-ceiling-antenna-617-6000-mhz-4.3-10-female-connector-pe51242-p.aspx>

The information contained in this document is accurate to the best of our knowledge and representative of the part described herein. It may be necessary to make modifications to the part and/or the documentation of the part, in order to implement improvements. Pasternack reserves the right to make such changes as required. Unless otherwise stated, all specifications are nominal. Pasternack does not make any representation or warranty regarding the suitability of the part described herein for any particular purpose, and Pasternack does not assume any liability arising out of the use of any part or documentation.

PE51242 CAD Drawing

Indoor DAS Ceiling Omni Antenna, 5 dBi, 617 MHz -
6000 MHz, 4 x 4.3-10 Female, Low PIM

REVISIONS			
REV.	DESCRIPTION	DATE	APPROVED
A	INITIAL RELEASE	06/08/2022	KHIETPAS

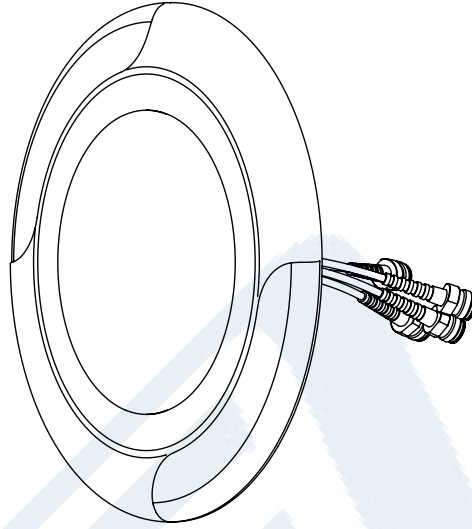
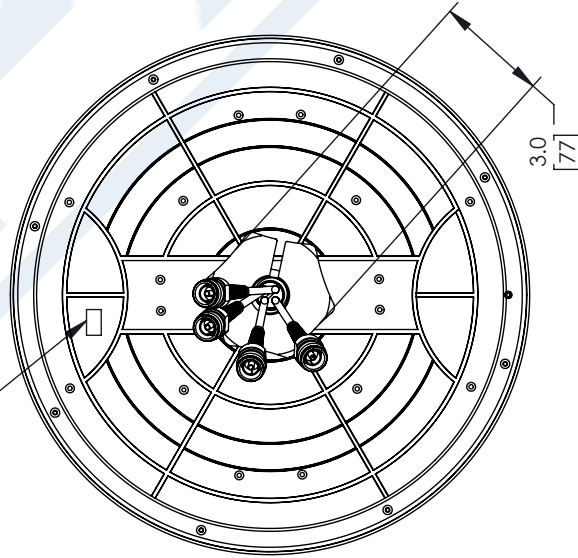
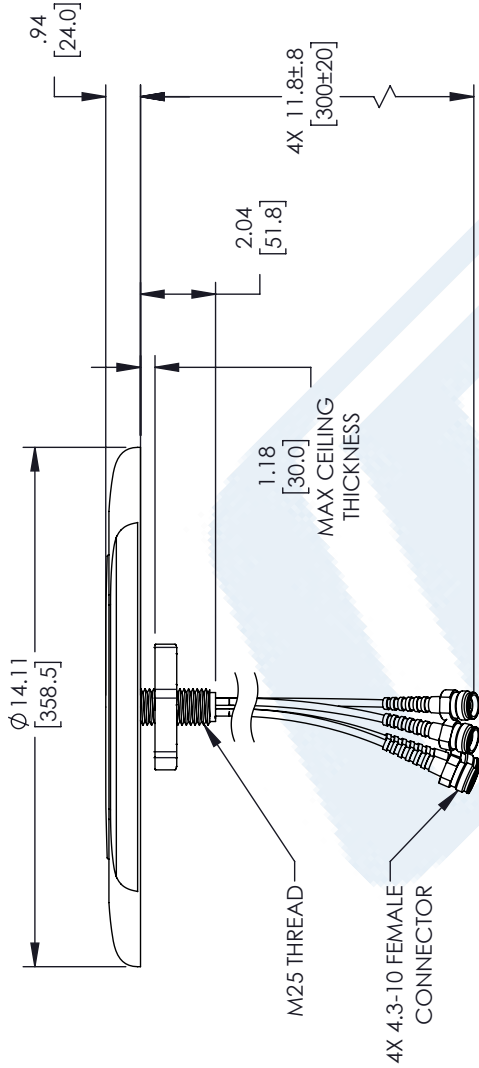

UNLESS OTHERWISE SPECIFIED LEADING DIMENSIONS ARE INCHES DIMENSIONS IN [] ARE MILLIMETERS

TOLERANCES:

.X = ±.2	[5.08]	FRACTIONS
.XX = ±.02	[.51]	± 1/32
.XXX = ±.005	[.13]	ANGLES ± 1°

CABLE LENGTH (L), TOLERANCES:

L ≤ 12	[305]	= +1 [25] / -0
12 [305] < L ≤ 60	[1524]	= +2 [51] / -0
60 [1524] < L ≤ 120	[3048]	= +4 [102] / -0
120 [3048] < L ≤ 300	[7620]	= +6 [152] / -0
300 [7620] < L		= +5% / -0

ALL DIMENSIONS SHOWN ARE FOR REFERENCE ONLY.

THIRD-ANGLE PROJECTION

THE INFORMATION AND DESIGN IN THIS DOCUMENT IS THE PROPERTY OF PASTERNAK CORPORATION ALL RIGHTS RESERVED.

SHEET 1 OF 1

SCALE N/A

REV A

PE PASTERNAK
an INFINITI® brand

Pasternack Enterprises, Inc.
P. O. Box 16759, Irvine, CA 92623.
Phone: 1.949.261.1920 | 1.866.727.8376
Fax: 1.949.261.7451
Website: www.pasternack.com
E-mail: sales@pasternack.com

ITEM NO. PE51242

SIZE A CAGE CODE 53919 DRAWN BY AKRESOWSK

NOTES:

1. LABEL PER ILS-100-03 (FOR INTERNAL REFERENCE ONLY). LABEL LOCATION FOR REFERENCE ONLY.

THESE COMMODITIES, TECHNOLOGY OR SOFTWARE WERE EXPORTED FROM THE UNITED STATES IN ACCORDANCE WITH THE EXPORT ADMINISTRATION REGULATIONS. DIVERSION CONTRARY TO U.S. LAW PROHIBITED.