

Flat suction cup (round)

SUF 8 SI-CO-55 M5-AG

Part no...:10.01.01.14244

<https://www.schmalz.com/10.01.01.14244>

Home > Vacuum Technology for Automation > Vacuum Components > Vacuum Suction Cups > Flat Suction Cups (Round) > Flat Suction Cups SUF > SUF 8 SI-CO-55 M5-AG

Flat suction cup (round) for process safe handling of smooth or slightly rough surfaces



Size: 8

Suction cup material: Silicone SI conductive

Material hardness [Shore A]: 55 Shore A

Vacuum connection: M5-M

Design Data

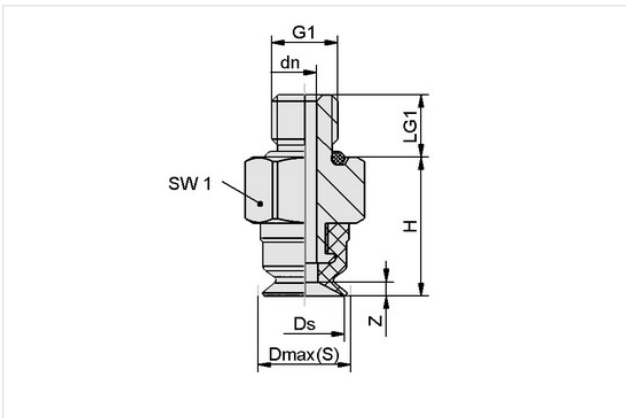

Attribute	Value
Dmax(S)	8.40 mm
Ds	8 mm
dn	1.80 mm
G1	M5-M
H	10.50 mm
LG1	4.70 mm
SW1	8 mm
Z (Stroke)	0.80 mm

Technical Data

Attribute	Value
Suction force (-600mbar)	2.40 N
Pull-off force	2.40 N
Volume	0.04 cm ³
Curve radius (min) (convex)	8 mm
Hose diameter (rec.) d	2 mm
Size	8
Suction cup material	Silicone SI conductive
Material hardness [Shore A]	55 Shore A

Contact Schmalz

Schmalz Inc. | 5850 Oak Forest Drive, Raleigh, NC 27616, United States | +1 (919) 713-0880 | schmalz.us@schmalz.com

Flat suction cup (round)

SUF 8 SI-CO-55 M5-AG

Part no...:10.01.01.14244

<https://www.schmalz.com/10.01.01.14244>

Weight	1.10 g
Product family	SUF
Number of folds	0

Note: Suction force: The specified suction forces are theoretical values at a vacuum of -0.6 bar and with a dry, smooth and flat workpiece surface - they do not include a safety factor
Hose diameter: The recommended hose diameter refers to a hose length of approx. 2 m

Spare parts



SC 020 M5-AG

Part no...:10.01.06.04273

Connection geometry: 020

Vacuum connection: M5-M

Fitting length: 5 mm

Nominal diameter dn: 1.8 mm



SUF 8 SI-CO-55 SC020

Part no...:10.01.01.14027

Size: 8

Suction cup material: Silicone SI conductive

Material hardness [Shore A]: 55 Shore A