

SMD (AEC-Q200) Pt-Temperature Sensor according to DIN EN 60751

Temperature range -50 °C to +130 °C (150 °C*)

The Pt-RTD SMD is designed for automatic mounting in large volume applications on printed circuit boards where long-time stability, reliability and low costs are important.

Nominal Resistance R_0 [Ω]	Tolerance	Type	Order Number	Packaging	Dimensions with Tolerances
Pt1000	F 0.3 (B)	0603	50 348 87	Blister reel	L1: 1.7 ±0.2 L2: 0.3 ±0.2 W: 0.9 ±0.2 H: 0.45 ±0.1
Pt1000	F 0.3 (B)	0805	50 348 86	Blister reel	L1: 2.3 ±0.2 L2: 0.3 ±0.2 W: 1.4 ±0.2 H: 0.6 ±0.1
Pt1000	F 0.3 (B)	1206	50 348 85	Blister reel	L1: 3.2 +0.2 -0.3 L2: 0.5 ±0.25 W: 1.6 ±0.2 H: 0.6 ±0.1

Temperature Range of Tolerance Class

Tolerance Class F 0.3 (B) -50 °C to +130 °C
*(With the use of expansion-matched circuit board materials temperatures up to +150 °C are possible)

Temperature Coefficient

TCR = 3850 ppm/K

Response Time

Water ($v = 0.4$ m/s) $t_{0.5} = 0.1$ s
 $t_{0.9} = 0.25$ s

Air ($v = 2$ m/s) $t_{0.5} = 2.5$ s
 $t_{0.9} = 8$ s

Measuring Current

Pt1000 Ω: 0.1 to 0.3 mA
(self-heating has to be considered)

Long-Term Stability

The drift of the resistance value at 0 °C after a storage for 1000 hours in air at the declared upper temperature limit is not more than the tolerance value of the declared tolerance class according DIN EN 60751.

Self-Heating

0.8 K/mW at 0 °C

Soldering Connection

End termination galvanic tin plated with Ni barrier layer

Connection Technology

Face up mounting; reflow soldering or wave soldering, e.g. double wave ≤ 8 s/235 °C

Packaging

Blister reel "Face-up" 4000 pcs/ reel.
Alternative packaging forms on request

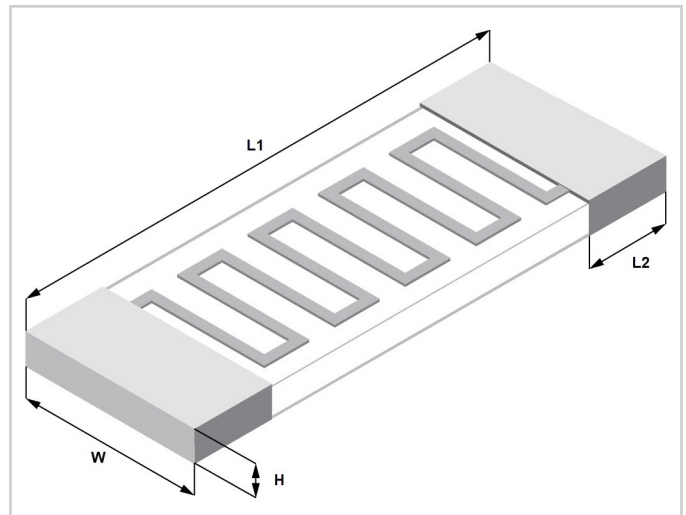

Image for illustration purposes only
Color, shape and forming of metallization may vary

Storage Life

At least 9 months (after manufacture), when stored under the recommended conditions. Longer shelf life may be possible, depending upon actual storage conditions, after requalification by customer. Nitrogen atmosphere recommended.

Note

Other tolerances and values of resistance are available on request

California Proposition 65



WARNING

This product can expose you to chemicals including nickel, which is known to the State of California to cause cancer. For more information go to www.p65warnings.ca.gov

SMD (AEC-Q200) Pt-Temperature Sensor according to DIN EN 60751

Temperature range -50 °C to +130 °C (150 °C*)

AEC-Q200, Rev. D - Qualification Matrix for Pt1000 SMD 0603, Pt1000 0805, Pt1000 1206

All tests are performed by an ISO 17025 certified laboratory.

Item	Standard	Test Conditions / Methods	Specifications
High Temperature Exposure (Storage)	MIL-STD-202 Method 108	Test temp.: 125 °C ± 3 °C Duration: 500 hours unpowered Measurement at 24 hours ± 2 hours after test conclusion	No visible damage $\left \frac{\Delta R_0}{R_0} \right \leq 0.1 \%$
Temperature Cycling	JESD22 Method JA-104	Test temp.: -55 °C / +125 °C (+10 °C / -0 °C) Soak time at lower or upper temp.: 30 min Number of cycles: 1000 Measurement at 24 hours ± 2 hours after test conclusion	No visible damage $\left \frac{\Delta R_0}{R_0} \right \leq 0.1 \%$
Biased Humidity	MIL-STD-202 Method 103	Test temp.: 85 °C ± 2 °C Rel. humidity of air: 85 % ± 3 % Duration: 1000 hours Measurement at 24 hours ± 2 hours after test conclusion	No visible damage $\left \frac{\Delta R_0}{R_0} \right \leq 0.1 \%$
Operational Life	MIL-STD-202 Method 108	Test temp.: 125 °C ± 3 °C Duration: 1000 hours Measurement at 24 hours ± 2 hours after test conclusion	No visible damage $\left \frac{\Delta R_0}{R_0} \right \leq 0.1 \%$
External Visual	MIL-STD-883 Method 2009	Inspect device construction, marking and workmanship	No visible damage
Physical Dimension	JESD22 Method JB-100	Verify physical dimensions to the applicable device specification	Within the specified values
Resistance to Solvents	MIL-STD-202 Method 215	Per MIL-STD-202 Method 215 2 parts solvent A, 2 parts solvent B, 1 part solvent D (brushed)	No visible damage
Mechanical Shock	MIL-STD-202 Method 213	Test Condition F Acceleration: 1500 g Half sine waveform Duration: 0.5 ms 3 shocks per direction, 6 directions at room temperature	No visible damage $\left \frac{\Delta R_0}{R_0} \right \leq 0.1 \%$
Vibration	MIL-STD-202 Method 204	Acceleration: 5 g Cycle time: 20 min Frequency range: 10 to 2000 Hz 12 cycles per axis 3 axes at room temperature	No visible damage $\left \frac{\Delta R_0}{R_0} \right \leq 0.1 \%$
Resistance to Soldering Heat	MIL-STD-202 Method 210	Condition B - No pre-heat of samples. Temp.: 260 °C ± 5 °C, Time: 10 s ± 1 s, 1 cycle	No visible damage $\left \frac{\Delta R_{RT}}{R_{RT}} \right \leq 0.5 \%$

SMD (AEC-Q200) Pt-Temperature Sensor according to DIN EN 60751

Temperature range -50 °C to +130 °C (150 °C*)

AEC-Q200, Rev. D - Qualification Matrix for Pt1000 SMD 0603, Pt1000 0805, Pt1000 1206

All tests are performed by an ISO 17025 certified laboratory.

Item	Standard	Test Conditions / Methods	Specifications
ESD	AEC-Q200-002	<p>Stress levels: 500V, 1000V, 2000V, 4000V, 6000V, 8000V, 12000V, 16000V, 25000V</p> <p>Zaps & Polarities: 1 zap, positive and negative per pin</p>	<p>SMD 0603: Product passed the component classification level 4 (4000 V)</p> <p>SMD 0805: Product passed the component classification level 3 (2000 V)</p> <p>SMD 1206: Product passed the component classification level 6 (8000 V)</p>
Solderability	J-STD-002	<p>a) Test condition J-STD-002D, condition B Ageing: 155 °C dry heat, 4 h Soldering temperature: 235 °C Dwell time: 5 s Flux: ROL 1 Solder bath: SnPb</p> <p>b) Test condition J-STD-002D, condition B, category C Ageing: Steam, 8 h Soldering temperature: 215 °C Dwell time: 5 s Flux: ROL 1 Solder bath: SnPb</p> <p>c) Test condition J-STD-002D, condition D, category C Ageing: Steam, 8 h Soldering temperature: 260 °C Dwell time: 30 s Flux: ROL 1 Solder bath: SnPb</p>	<p>Min. 95 % of termination is covered by solder</p>
Electrical Characterization	Specifications	<p>a) T1 = 0 °C b) T2 = -40 °C c) T3 = 130 °C</p>	<p>Within the specified values</p>
Board Flex	AEC-Q200-005	<p>Bending of board: 2mm (Min.) Duration: 60 (+5) s</p>	<p>No visible damage $\left \frac{\Delta R_{RT}}{R_{RT}} \right \leq 0.5 \%$</p>
Terminal Strength	AEC-Q200-006	<p>Applied force: 1.8 kg (17,7N) Duration of the applied forces: 60 (+1) s</p>	<p>No visible damage $\left \frac{\Delta R_{RT}}{R_{RT}} \right \leq 0.5 \%$</p>

SMD (AEC-Q200) Pt-Temperature Sensor according to DIN EN 60751

Temperature range -50 °C to +130 °C (150 °C*)

YAGEO Nexensos internal test

Item	Standard	Test Conditions / Methods
Multiple Solderability	According to IPC/JEDEC J-STD-020E norm	According to internal Heraeus tests, the component is suitable for 3 heat cycles (reflow soldering) with > 60 seconds above liquidus (217 °C)



The information provided in this data sheet describes certain technical characteristics of the product, but shall not be qualified or construed as quality guarantee (Beschaffenheitsgarantie) in the meaning of sections 443 and 444 German Civil Code. The information provided in this data sheet regarding measurement values (including, but not limited to, response time, long-term stability, vibration and shock resistance, insulation resistance and self-heating) are average values that have been obtained under laboratory conditions in tests of large numbers of the product. Product results or measurements achieved by customer or any other person in any production, test, or other environment may vary depending on the specific conditions of use. The customer is solely responsible to determine whether the product is suited for the customer's intended use; in this respect YAGEO Nexensos cannot assume any liability. The sale of any products by YAGEO Nexensos is exclusively subject to the General Terms of Sale and Delivery of YAGEO Nexensos in their current version at the time of purchase, which is available under www.yageo-nexensos.com/tc or may be furnished upon request. This data sheet is subject to changes without prior notice.

YAGEO Nexensos GmbH, Reinhard-Heraeus-Ring 23, 63801 Kleinostheim, Germany