

AS6031



Ultrasonic flow converter for the next generations of ultrasonic water and heat meters

- Ultrasonic frontend (UFE) for ultrasonic flow measurement and temperature measurement including programable gain amplifier
- Digital core with the supervisor and task sequencer, the frontend processing unit, the CPU and memory
- Advanced high-precision analog front-end
- Compact design – low BOM

AS6031

Ultrasonic flow converter for the next generations of ultrasonic water and heat meters

AS6031 is an ultrasonic flow converter for the next generations of ultrasonic water and heat meters. It is highly integrated and is based on the TDC-GP30 platform. It uses the same high-performant front-end for driving the transducers and processing the receive signal to extract the time of flight information.

An additional programmable amplifier allows handling weaker receive amplitudes. Additional features for phase-modulated hit identification give even more robustness to the first hit level detection. The integrated low-power CPU can use 4k of NVRAM and 4k of ROM code to do the flow calculation on chip.

Benefits

- Single-chip solution allows on-chip processing
- System design compatible with mechanical meters
- High flexibility in choice for external μP handling communication and further data management
- Precision down to low flow rates
- Leakage detection
- Handles weak signals for small transducers and multiple reflections

Features

- High performance + ultra-low power 32-Bit CPU
- 120 * 32-bit NVRAM (non-volatile RAM)
- 3968 * 8-bit NVRAM (non-volatile RAM)
- 4k * 8-bit ROM for system task code and flow code
- Advanced high-precision analog front-end for transducer frequencies of 50 kHz to 4 MHz at 2.5 V to 3.6 V drive voltage
- Integrated PGA, gain 2 to 17 V/V @ 1 MHz
- First hit level and phase detection
- Amplitude measurement
- Up to 31 zero crossing measurements
- Ultra-low power consumption with only $8\mu\text{A}$ at 8 Hz

Properties

- SPI serial interface
- General Purpose I/O Unit incl. pulse interface and 2-wire master interface (I2C like)
- Supply voltage 2.5(1) to 3.6 V
- 3.0 to 3.6 V NVRAM store only
- Operating temperature -40 to 85°C
- QFN48 package ($7 \times 7\text{mm}^2$)

Applications

- Water meters for utilities
- Industrial water meters
- Heat meters
- Gas meters
- Volume counters

Block Diagram

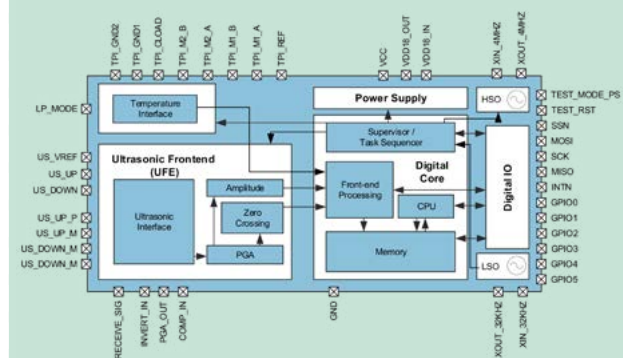

SciSense B.V.

High Tech Campus 10 • 5656 AE Eindhoven • The Netherlands • info@sciosense.com

SciSense is a Joint Venture of ams AG

Sensing tomorrow's world

www.sciosense.com