



This product, formerly sold by ams AG, and before that optionally by either Applied Sensors GmbH, acam-messelectronic GmbH or Cambridge CMOS Sensors, is now owned and sold by

SciSense

The technical content of this document under ams / Applied Sensors / acam-messelectronic / Cambridge CMOS Sensors is still valid.

Contact information

Headquarters:

Sciosense B.V.

High Tech Campus 10

5656 AE Eindhoven

The Netherlands

info@sciosense.com

www.sciosense.com

Clearer Images with Lower Dose

www.ams.com/TDC-GPX2



TDC-GPX2 – 4-channel Time-to-Digital Converter

- Industry-best combination of speed, precision and power
- Resolution on each channel down to 8ps rms
- High measurement rate up to 70 MSamples/s
- Only 450 mW at maximum sample rate with LVDS readout

**Sensing
is life.**

General Description

The TDC-GPX2 is an integrated four-channel converter IC offering single-measurement resolution of up to 20 ps rms per channel in normal mode. Operating in high-resolution mode, it can achieve a maximum resolution of 8 ps rms, and adding dual-channel mode, 5ns pulse-to-pulse spacing is possible. The superior performance of the TDC-GPX2 has been achieved without sacrificing power efficiency: The product uses between 60 mW and 450 mW in normal operation, and draws just 60µA in stand-by mode.

The new, high sampling speed and great precision will enable PET scanners to achieve greater contrast while reducing the patient's exposure time. LIDAR systems in cars, drones and robots will be able to achieve better object detection and avoidance as a result of the more detailed and accurate ranging measurements.

ams has put particular emphasis on making the TDC-GPX2 easy to implement in end-product designs, providing standard interfaces like serial LVDS or SPI and having fully calibrated time data as output. The chip also includes a driver for a quartz reference clock, which can be used for automatic calibration alternatively to the reference input. In general, the device needs only a few external components.

In addition, ams supplies an evaluation kit, the GPX2-EVA-KIT, which includes a programmer and GUI software for PCs, enabling users to configure and connect their Start and Stop signals and begin taking sample time measurements within minutes.

Applications

- Laser range finders
- Laser scanners in robots
- ADAS
- PET imaging
- ToF spectroscopy
- Particle detection
- ATE

Features

- 4 stop channels with serial 20ns pulse-to-pulse spacing at maximum 35MSPS
- 2 combined channels with 5ns pulse-to-pulse spacing at maximum 70MSPS
- Single shot accuracy 20ps rms per channel, 10ps rms with high resolution option
- Unlimited measuring range 0s to 16s
- Inputs optional with LVDS or CMOS level
- Readout with LVDS or SPI
- Automatic calibration to reference clock
- Power dissipation 60 to 450mW
- QFN64 or QFP64 packages

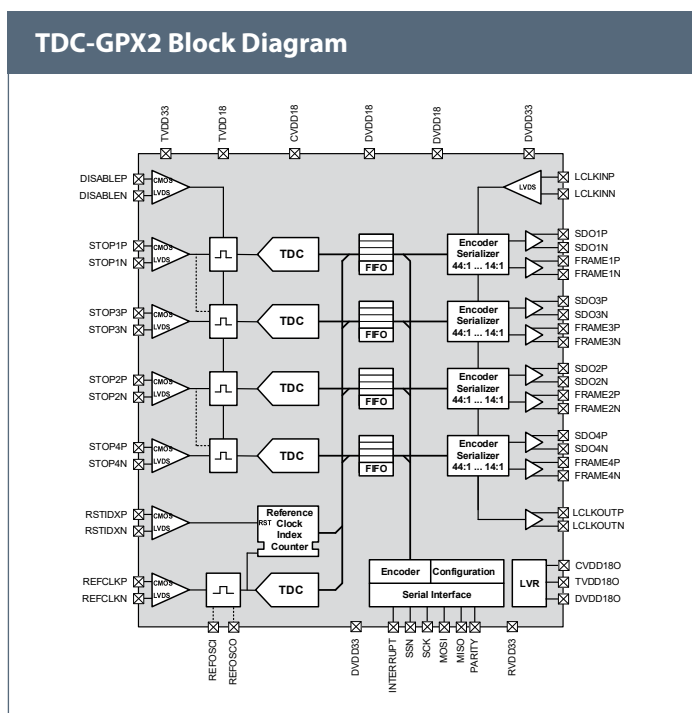

Benefits

- Superior audio quality
- Simple data post-processing thanks to calibrated results
- Event assignment thanks to reference clock index simplifies coincidence measurements
- High efficiency thanks to high sample rate
- High contrast thanks to high resolution

www.ams.com
 sensors@ams.com
 © 08/2018 by ams
 Subject to change without notice

Headquarters
 ams AG
 Tobelbader Strasse 30, 8141 Premstaetten, Austria
 Phone +43 3136 500-0

Sales Offices Worldwide
 sales-europe@ams.com
 sales-asia@ams.com
 sales-americas@ams.com