

6

5

4

3

2

1

D

C

B

A

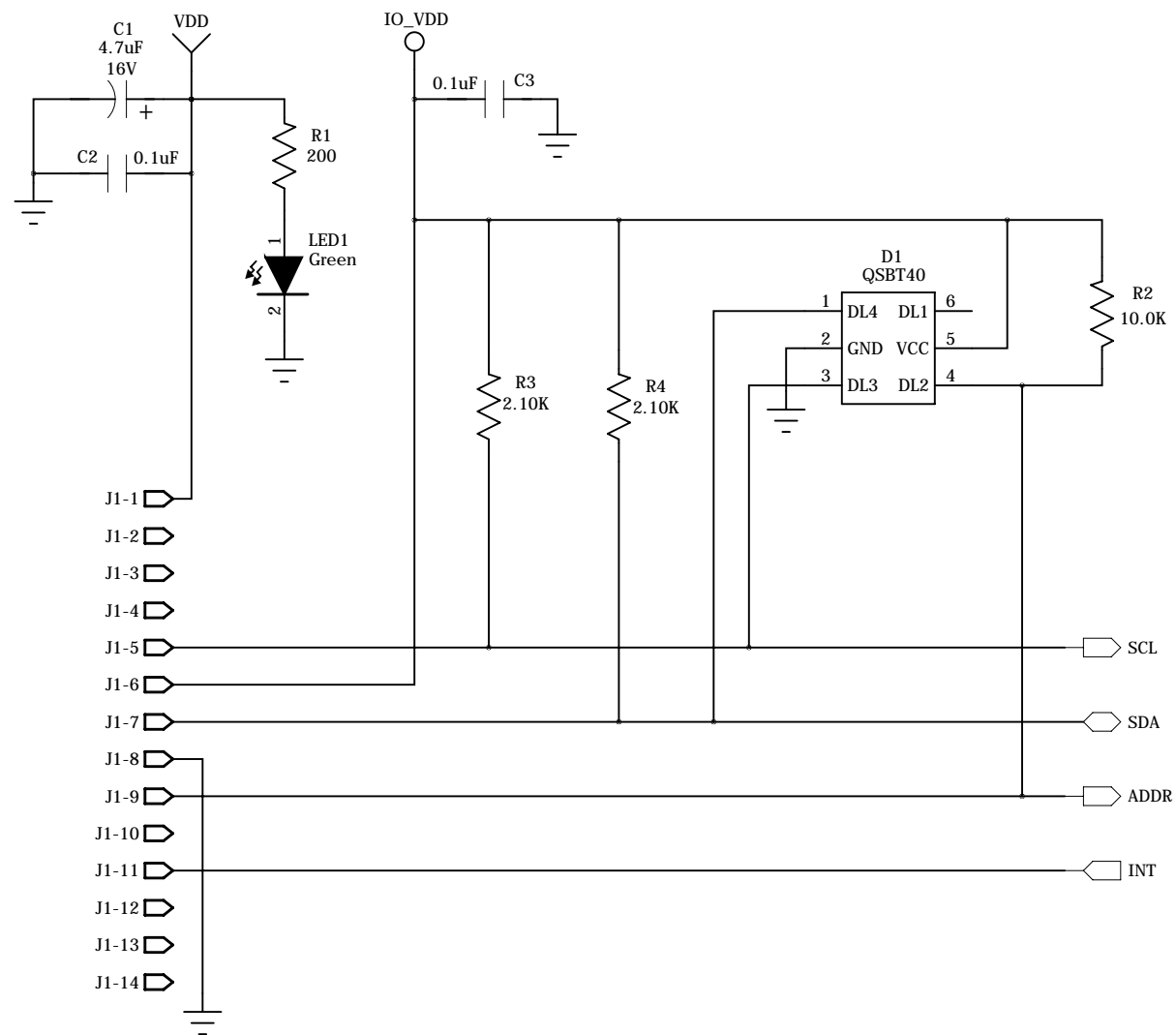

NOTES:

- 1) All resistors are 1%, 1/10W, 0603 unless otherwise specified.
- 2) All capacitors are 0.1uF, 10%, 50WVDC, 0603 unless otherwise specified.
- 3) U1B Socket: Loranger, SOCKET\_020SQ012J6618A
- 4) Supported device and 7-bit I2C address:
  - a) KXTJ2: 0Eh, 0Fh.
  - b) KXTJ3: 0Eh, 0Fh.

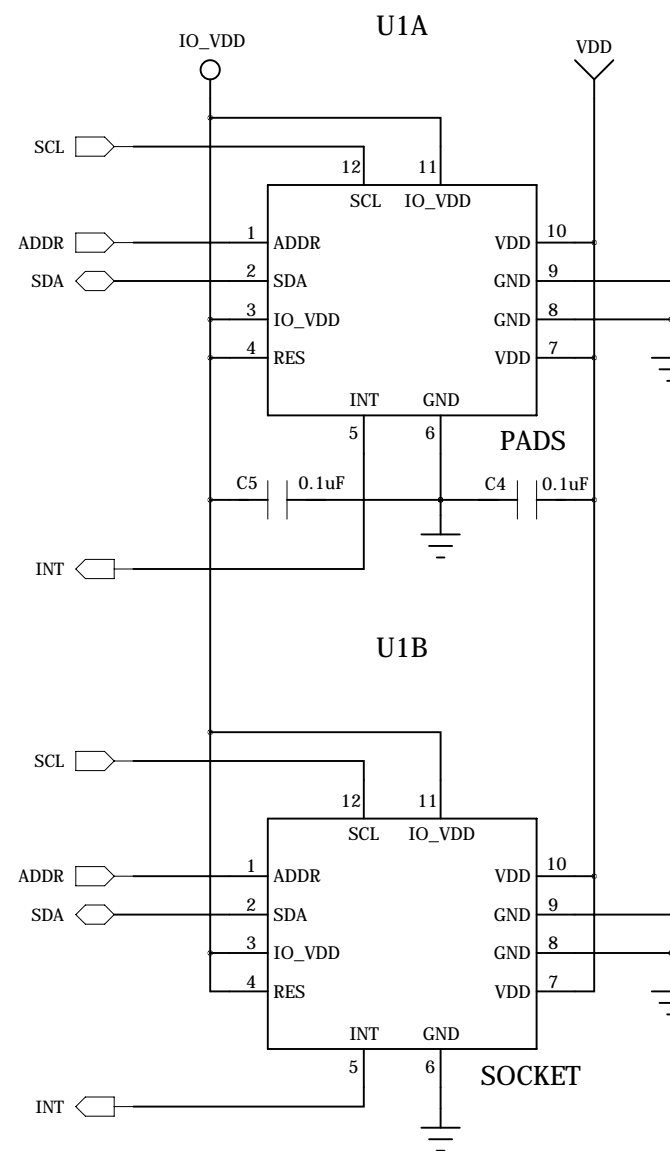

PIN	KXTJ2	KXTJ3	
1	ADDR	ADDR	
2	SDA	SDA	
3	IO_VDD	IO_VDD	
4	RES	RES	
5	INT	INT	
6	GND	GND	
7	VDD	VDD	
8	GND	GND	
9	GND	GND	
10	VDD	VDD	
11	IO_VDD	IO_VDD	
12	SCL	SCL	

D

C

B

A

COMPANY: **Kionix Inc.**

TITLE: **KXTJ2 Evaluation Board Rev 1**

DRAWN: <b>J Zappala</b>	DATED: <b>10/04/2015</b>	CODE: <b>DWG791</b>	SIZE: <b>B</b>	DRAWING NO: <b>KAMMDM001R54</b>	REV: <b>1</b>
CHECKED:	DATED:	SCALE: NONE		SHEET: 1 OF 2	
QUALITY CONTROL:	DATED:				
RELEASED:	DATED:				

DRAWN: <b>J Zappala</b>	DATED: <b>10/04/2015</b>
CHECKED:	DATED:
QUALITY CONTROL:	DATED:
RELEASED:	DATED:

