

Carrier_BT807042_SOIC-8_v LCP



Image is for illustration purposes only. Please refer to product description.

Part number	78 01 030 0004
Specification	Carrier_BT807042_SOIC-8_v LCP
HARTING eCatalogue	https://b2b.harting.com/78010300004

Identification

Category	Surface Mount Device
Series	3D-MID
Element	Carrier for electronic components
Specification	Interconnection
Features	Other materials or trace layouts on request!

Version

Fixing	PCB assembly (SMD)
Pack contents	Tape & reel 1200 pieces on reel Lower quantities available on request!

Technical characteristics

Operating temperature	-40 ... +125 °C
Storage temperature	-40 ... +125 °C

Material properties

Material	Liquid crystal polymer (LCP)
Surface (contacts)	Au ($\geq 0.05 \mu\text{m}$) over Ni ($\geq 4 \mu\text{m}$) over Cu (5...11 μm)
Length	8 mm
Width	7 mm
Height	4.2 mm
RoHS	compliant
ELV status	compliant

Material properties

China RoHS	e
REACH Annex XVII substances	Not contained
REACH ANNEX XIV substances	Not contained
REACH SVHC substances	Not contained
California Proposition 65 substances	Not contained

Commercial data

Packaging size	600
Net weight	0.792 g
Country of origin	Switzerland
European customs tariff number	85389099
GTIN	5713140277380
ETIM	EC002637
eCl@ss	27469090 PCB connection technology (other, unspecified)

Other materials or trace layouts on request!



Drawing (dimensions in mm)

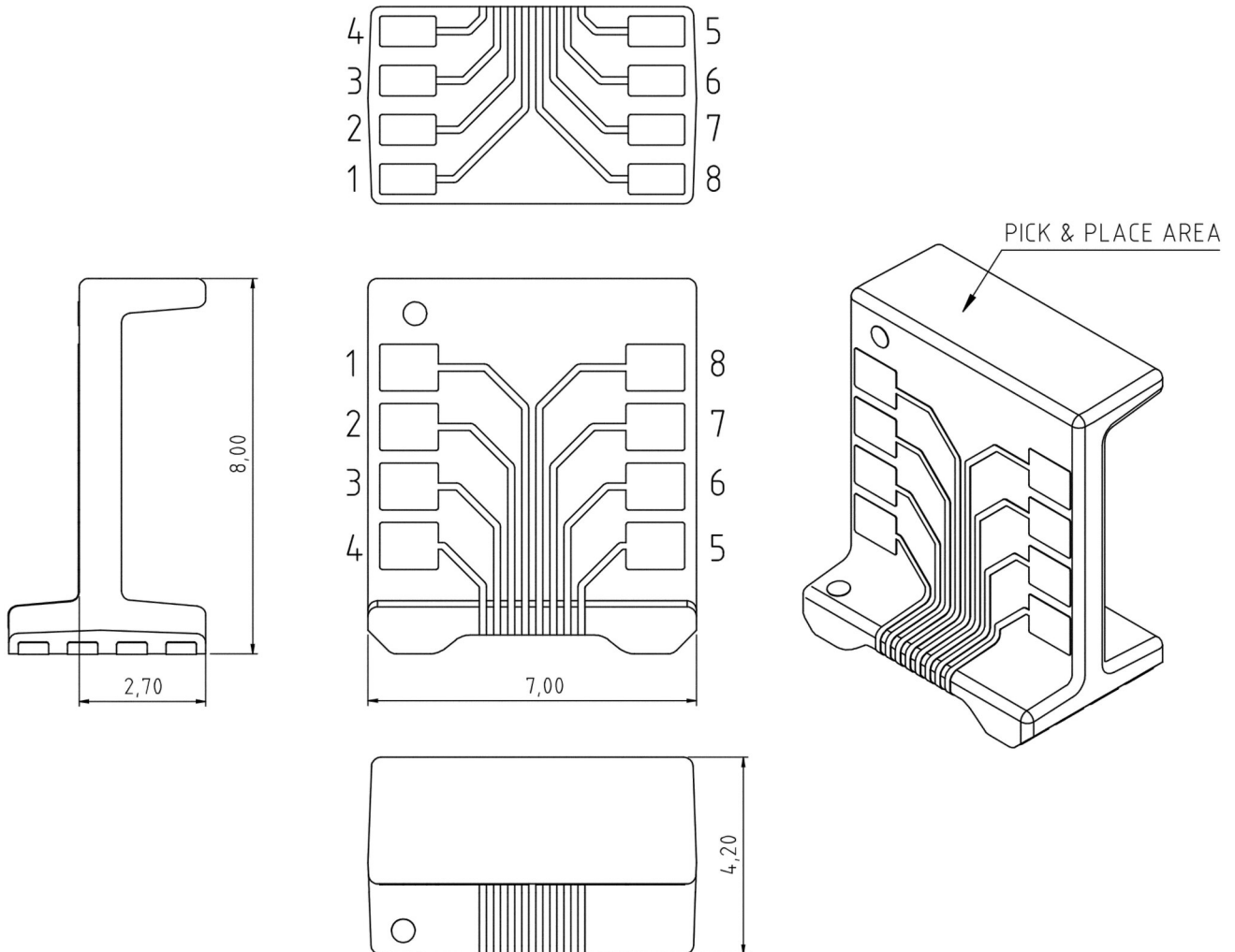

Drawing (dimensions in mm)

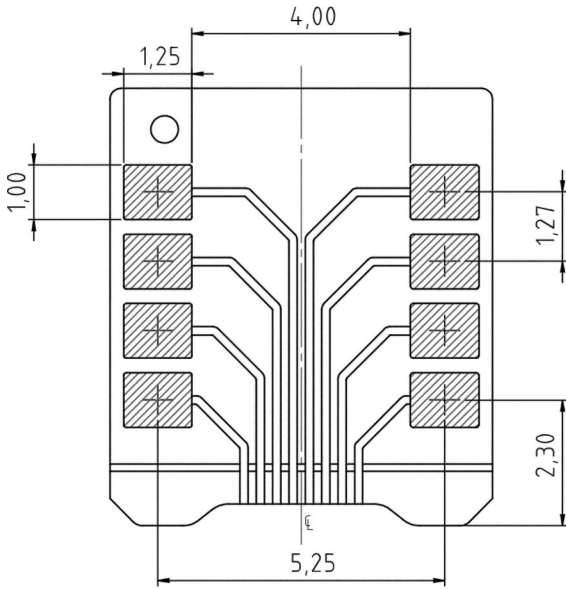

COMPONENT PADS LAYOUT
 SOIC-8

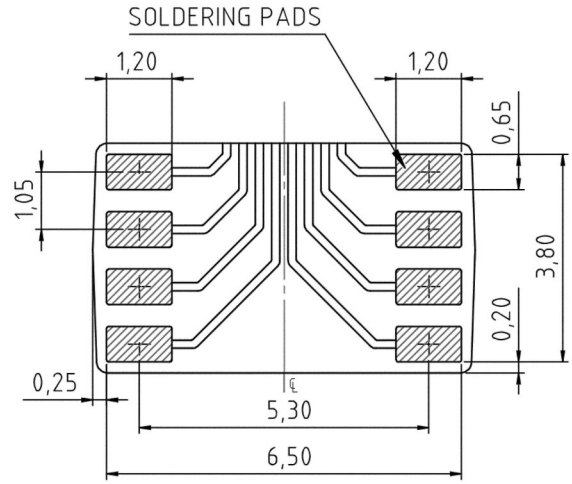

CARRIER PATTERN LAYOUT

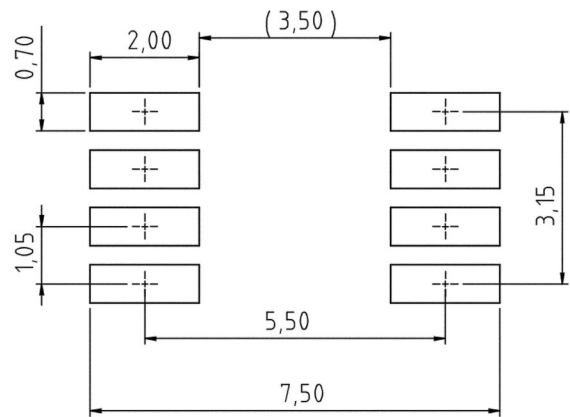
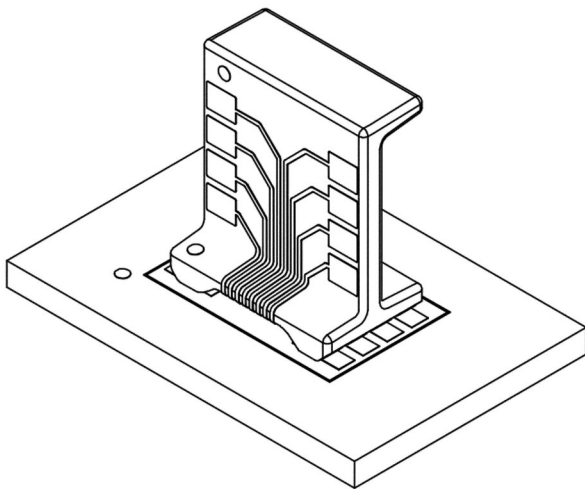

RECOMMENDED PCB PATTERN LAYOUT



Pushing Performance
 Since 1945

Soldering instructions

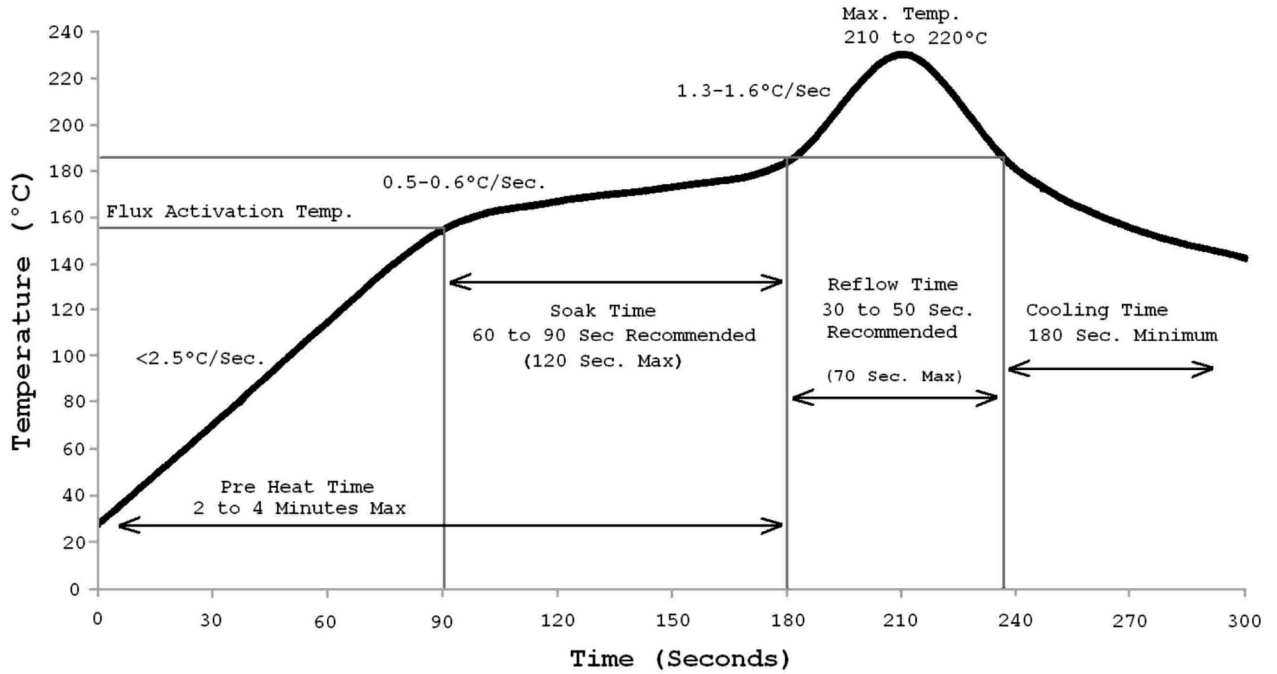

PB-free soldering profile
 (J-STD-020C)

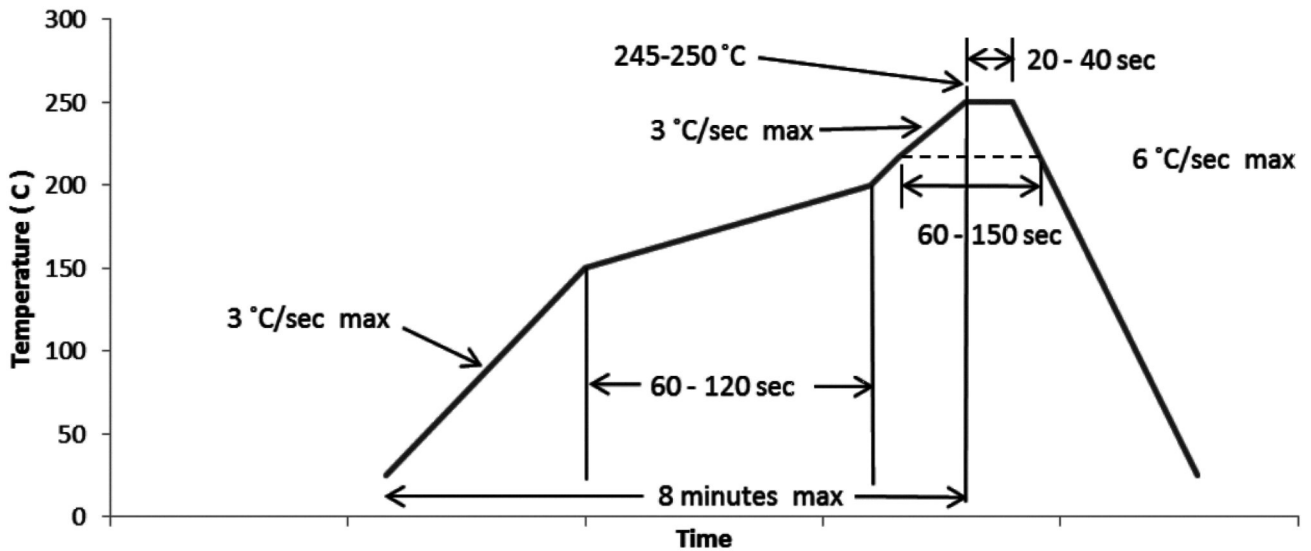



Pushing Performance
Since 1945

Tape layout & packaging

