



ZION™ 2nd Gen



ZION 2nd Gen wall pack is the newest, and feature rich wall-pack of 2023. Its unique and sleek design offers three wattages and CCT adjustable. Zion 2nd Gen comes with energy-efficient LED technology and has Built-in photocell. ZION 2nd Gen luminaires comes with die cast aluminum housings and a polycarbonate lens to stand up for many years of punishing environmental conditions.

Product Features

- Up to 135 Lumens per watt
- Wattage adjustable
- CCT Adjustable
- Durable die-cast aluminum housing with dark bronze powder coat finish
- Lumileds 2835, high CRI
- 0-10V Dimmable
- Built-in photocell
- Diffuser Type Glass Lens
- Input voltage 120-277VAC
- No UV or IR in the beam
- Light is soft and uniform, safe to eyes
- Instant start, NO flickering, NO humming
- Rated IP65 with sealed and gasketed wire way enclosure provides a water-tight seal
- UL & DLC Listed
- 5 Year warranty

ZION™ 2nd Gen



SKU #	Model #	Wattage Adj.	Lumens	CCT Adj.	IP	Dimming	Housing	Input Voltage	Certifications
156183	LoreBLT-SWP09M-60H BSGDA1-BR30/40/50W	30W/40W/60W	8100Lm	3K/4K/5K	IP65	0-10V	Bronze	120-277Vac	UL & DLC
156184	BLT-SWP09M-120B BSGDA1-BR30/40/50W	80W/100W/120W	16200Lm	3K/4K/5K	IP65	0-10V	Bronze	120-277Vac	UL & DLC

SKU Number 156183 Specifications

Parameter	Description	Value
General Performance	Model #	BLT-SWP09M-60HBSGDA1-BR30/40/50W
	Wattage Adjustable	30W/40W/60W
	Lumen	8100Lm
	Lumen Efficacy	Up to 135LM/W
	Color Temperature	3000K/4000K/5000K
	CRI (Ra)	>80
	Beam Angle	110° Degree
	Diffuser Type	Glass Lens
Electrical	Input Voltage	120-277Vac
	Frequency	50/60Hz
	Dimming	0-10V
	Power Factor	≥0.9
	Flicker Percent	N/A
	Driver Brand	Beyond
	Driver Model	HB-FL19F060
Driver Surge Protection	L/N-PE: 2.5kV, L-N: 2.5kV	
Physical	Operating Temperature	-40°C TO 45°C, Sensor :-25°C TO 50°C
	Operating Humidity	20% - 90%RH
	Storage Temperature	-40°C - 80°C
	Storage Humidity	10% - 95% RH
	LED Brand	Lumileds
	LED Type	SMD2835
	LED QTY	152PCS*2
	Housing Material	Die-Cast Aluminum
	Housing Color	Bronze
Qualification	IP Rating	IP65
	Warranty	5 Year



ZION™

2nd Gen

SKU Number 156184

Specifications

Parameter	Description	Value
General Performance	Model #	BLT-SWP09M-120BBSGDA1-BR30/40/50W
	Wattage Adjustable	80W/100W/120W
	Lumen	16200Lm
	Lumen Efficacy	Up to 135LM/W
	Color Temperature	3000K/4000K/5000K
	CRI (Ra)	>80
	Beam Angle	110° Degree
	Diffuser Type	Glass Lens
Electrical	Input Voltage	120-277Vac
	Frequency	50/60Hz
	Dimming	0-10V
	Power Factor	≥0.9
	Flicker Percent	N/A
	Driver Brand	Beyond
	Driver Model	BQE120C-130-PVF-Z
	Driver Surge Protection	L/N-PE: 6kV, L-N: 4kV
Physical	Operating Temperature	-40°C TO 45°C, Sensor :-25°C TO 50°C
	Operating Humidity	20% - 90%RH
	Storage Temperature	-40°C TO 80°C
	Storage Humidity	10% - 95% RH
	LED Brand	Lumileds
	LED Type	SMD2835
	LED QTY	312 PCS*2
	Housing Material	Die-Cast Aluminum
Qualification	Housing Color	Bronze
	IP Rating	IP65
	Warranty	5 Year



Correlated Color Temperature (CCT)

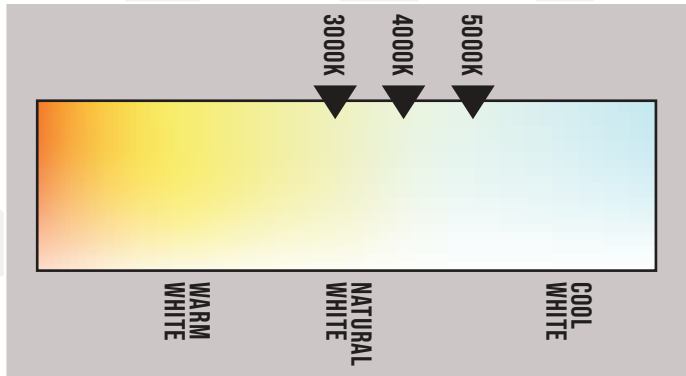

Dimensions

SKU: 156183

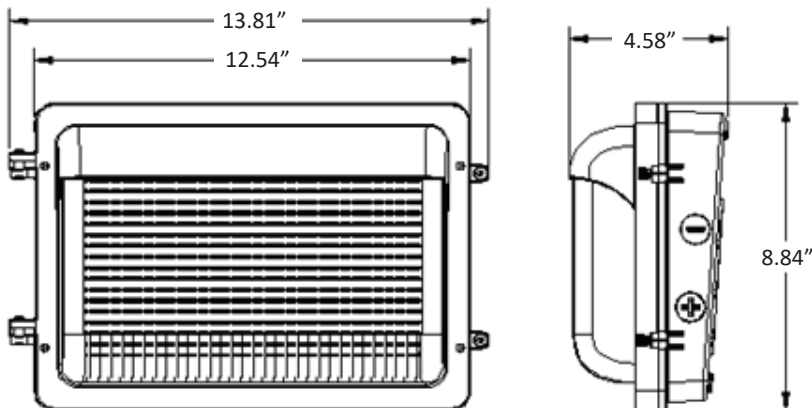

SKU: 156184

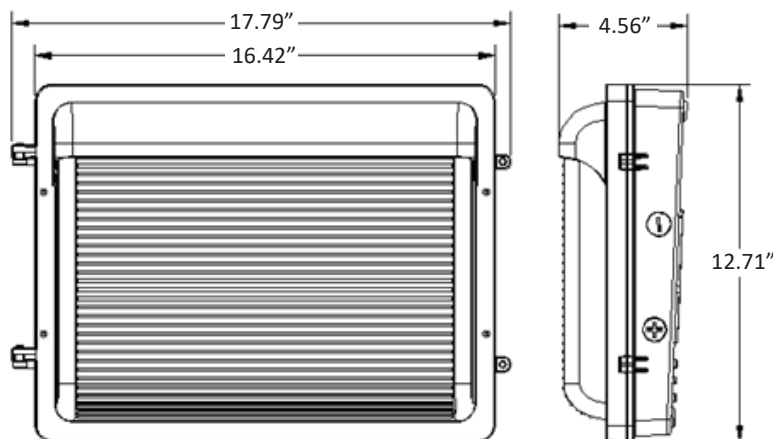



ZION™ 2nd Gen

SKU: 156183

Photometric Result

IES Classification: Type IV
 Total Rated Lamp Lumens: 7779.8 lm
 Efficiency: 100%
 Upward Ratio: 12%
 C0r0 Intensity: 930 cd
 Pos of Max. Intensity: H90 V62

Longitudinal Classification: Very Short
 Measurement Flux: 7779.8 lm
 Downward Ratio: 88%
 Luminaire Efficacy Rating (LER): 134.72
 Max. Intensity: 3699.13 cd

Luminous Intensity Distribution Curve

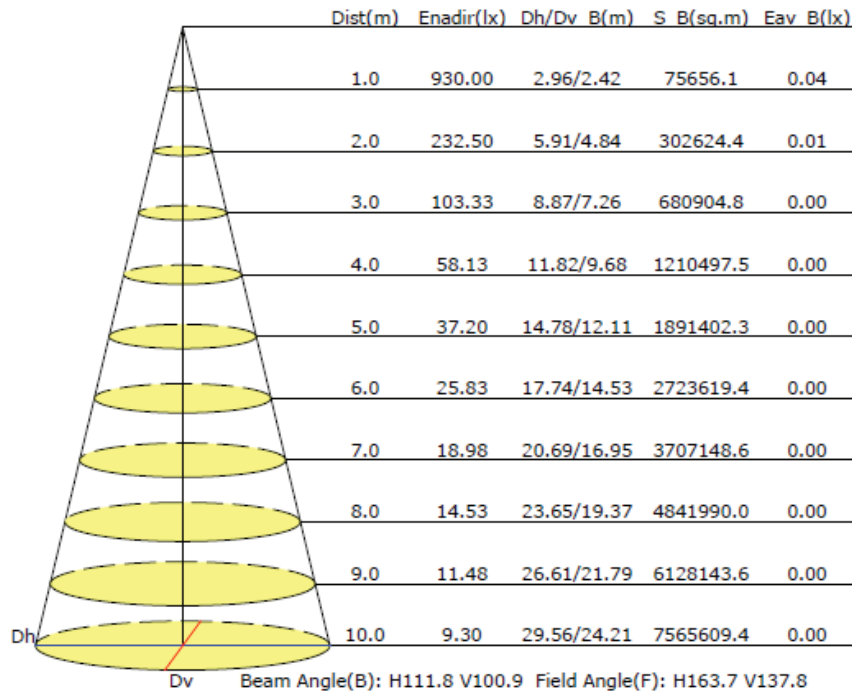
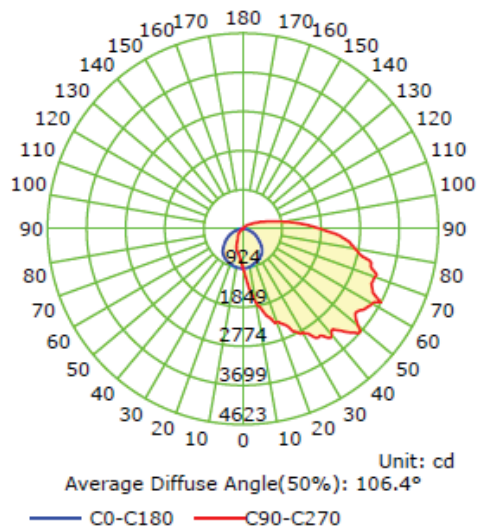



SKU: 156184

Photometric Result

IES Classification: Type IV
 Total Rated Lamp Lumens: 16261.9 lm
 Efficiency: 100%
 Upward Ratio: 11%
 C0r0 Intensity: 2797.96 cd
 Pos of Max. Intensity: H90 V55

Longitudinal Classification: Very Short
 Measurement Flux: 16261.9 lm
 Downward Ratio: 89%
 Luminaire Efficacy Rating (LER): 131.67
 Max. Intensity: 7776.02 cd

Luminous Intensity Distribution Curve

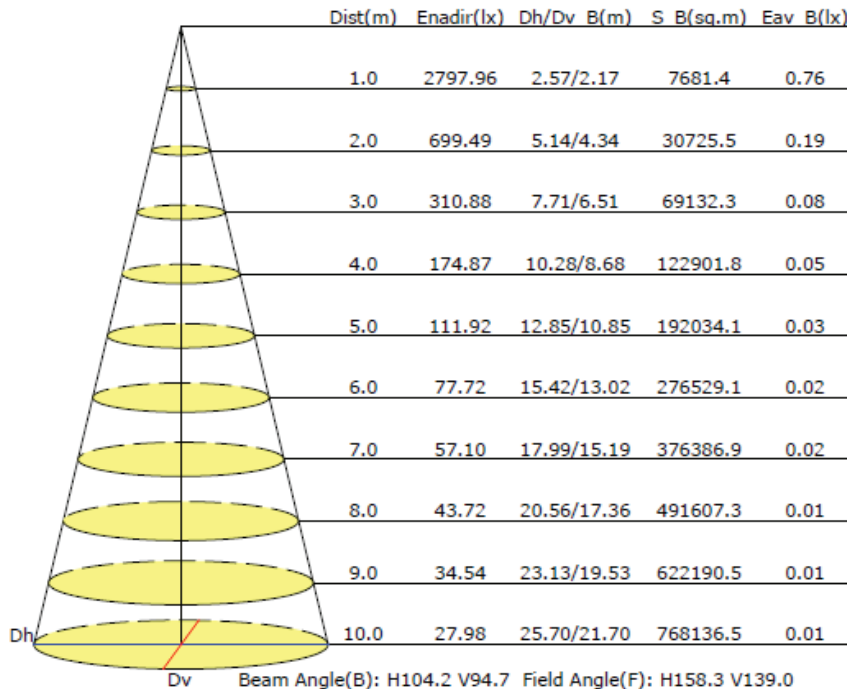
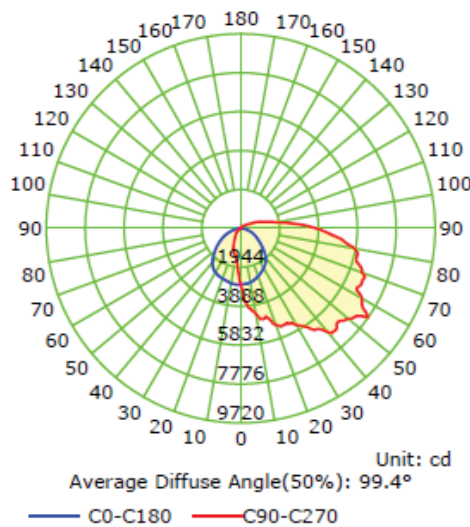



ZION™

2nd Gen

Installation

Applications:

Tunnel (except for motor vehicle tunnel), workshop, warehouse, factory, house, building exterior, etc.

Cautions:

1. Do not use an electric generator to test the LED fixture.
2. Please abide by appropriate national, regional and local law and regulations when install this fixture.
3. Do not install the fixture when raining to lower the risk of electric shock and avoid failure.

Cautions:

1. To avoid possibility of electrical shock or fire, the installation personnel must have professional electric knowledge.
2. Wear gloves to avoid injury before installation.
3. If any smoke or spark of the wire happened, please turn off the power immediately and notify relevant personnel.
4. This fixture is available in outdoor usage, but the distance from fixture to ground should be more than 2m.

This installation instruction applies to the following products. Although the products vary in appearance, the installation steps are the same.

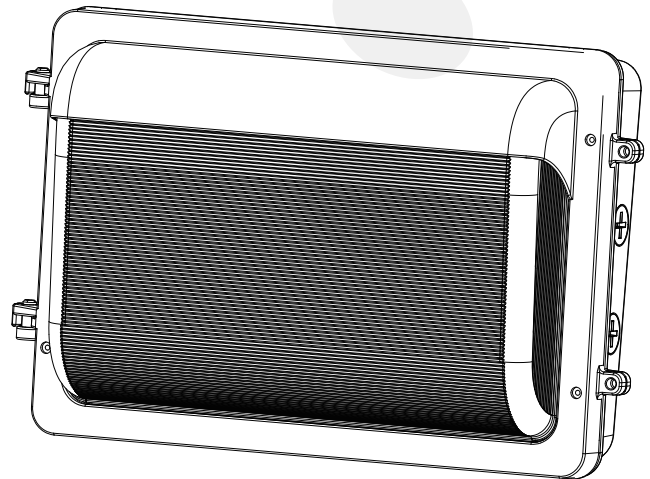
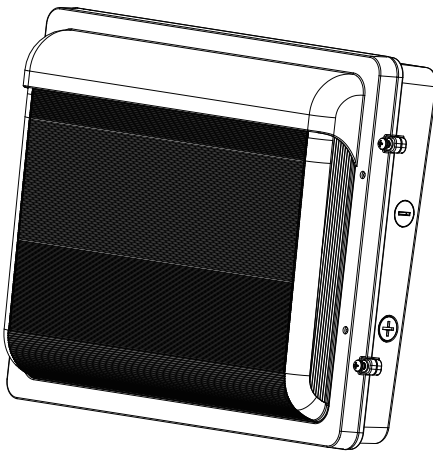



Installation

Installation I:

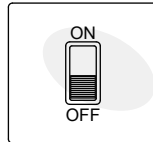

1. Turn off the power.

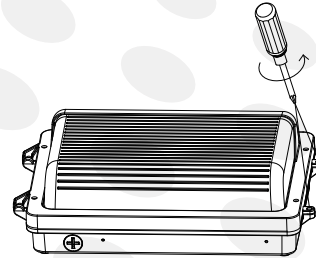

2. Use a screwdriver to remove the screws on both sides.

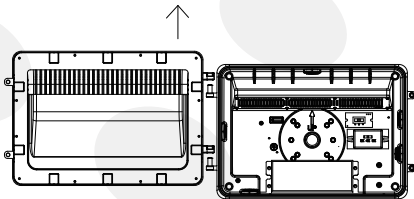

3. Open the fixture, and remove the upper cover of the fixture.

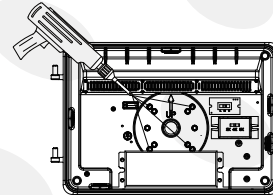

4. Drill mounting holes with an electric drill.

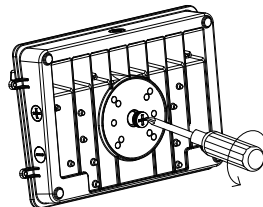

5. Use a screwdriver to remove the plug, Attach the EVA cotton pad to bottom.

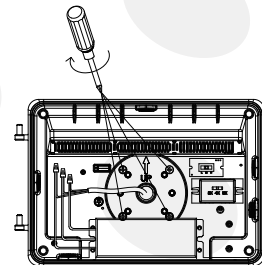

6. Lock the bottom shell on the mounting seat with screws, Connect the L, N and G wires to the power supply.

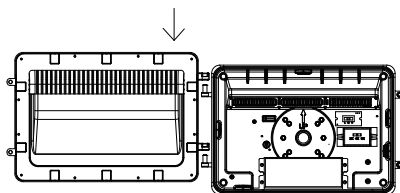

7. Mount the cover of the fixture.

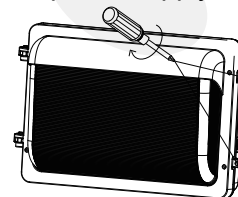

8. Fix the fixture with screws.

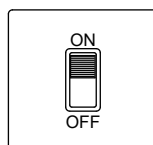

9. Make sure the installation is complete before turning on the power switch.



ZION™ 2nd Gen

Installation

Installation II:

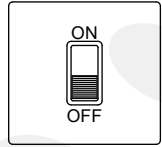

1. Turn off the power.

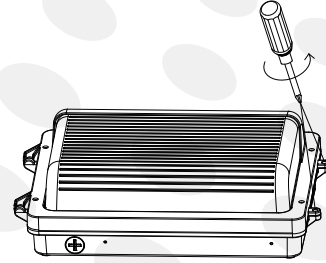

2. Use a screwdriver to remove the screws on both sides and remove the upper cover of the fixture.

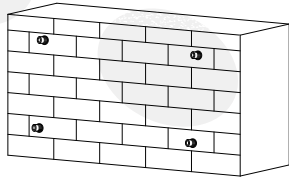

3. Drill mounting holes with an electric drill. Push the expansion rubber plug into the mounting hole on the wall.

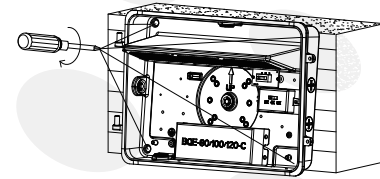

4. Lock the bottom shell on the mounting seat with screws.

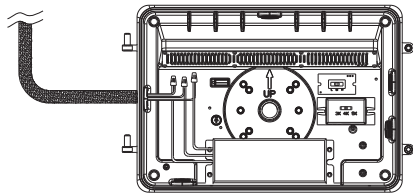

5. Connect the L, N and G wires to the power supply.

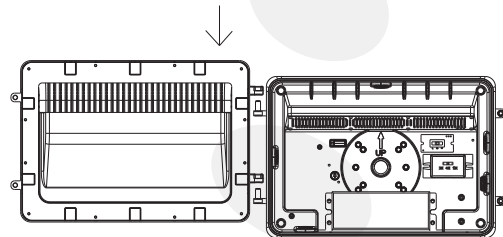

6. Mount the cover of the fixture

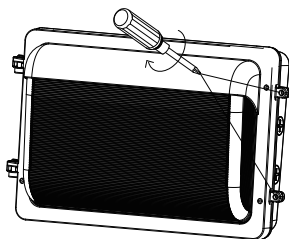

7. Fix the fixture with screws

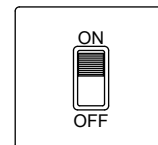

8. Make sure the installation is complete before turning on the power switch.



Installation

Standard wire:

L/live wire: Black\Brown; N/null wire: White\Blue; Ground wire: Green\Yellow-green.

Warning: During grounding, make sure the earth wire of the driver and fixture housing are connected together with the earth wire of the local power supply.

Operate as following instructions if the product is designed with below functions

Special functions instruction :

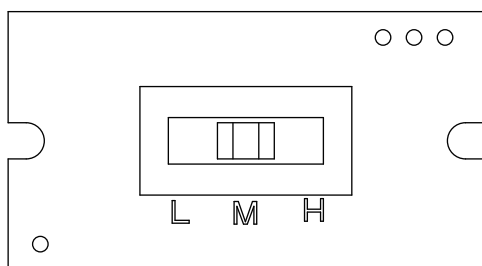

Wattage adjustable instruction

Turn the wattage adjustable knob to a certain wattage gear, the power of the lamp will change to the corresponding wattage.

Adjustable wattage range 25%-100%.

Note: Please turn off the power before adjusting the wattage.

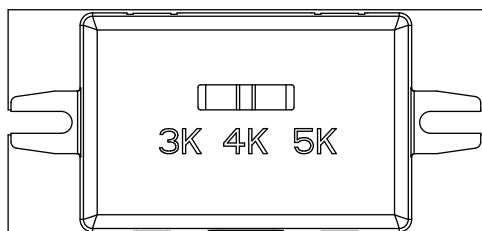

Color tunable instruction

1. The color temperature of the lamp turns to 3000K when the switch is set to 3K.
2. The color temperature of the lamp turns to 4000K when the switch is set to 4K.
3. The color temperature of the lamp turns to 5000K when the switch is set to 5K.

Note: Please turn off the power before adjusting the color temperature.



ZION™ 2nd Gen

Notice For User

- Please turn off power before install or change assembly parts.
- The input voltage and lamps should be matched, after connecting the power line, Please make sure the wiring section is insulated.
- No-professionals, must not install and disassemble the lamps.

TROUBLE SHOOTINGS

Troubles	Check points
Flickering of the light	Turn off the power and turn on again in 3 minutes. If same phenomena occur, then call agencies.
Out of working	Please check the connection.

Packaging

Carton Type	Carton Size (Inches)	Qty	Net Weight	Gross Weight
156183	15.07 x 10.63 x 6.50	1 Pc/Box	8.37 LBS	10.58 LBS
156184	18.90 x 14.76 x 6.69	1 Pc/Box	8.37 LBS	10.58 LBS

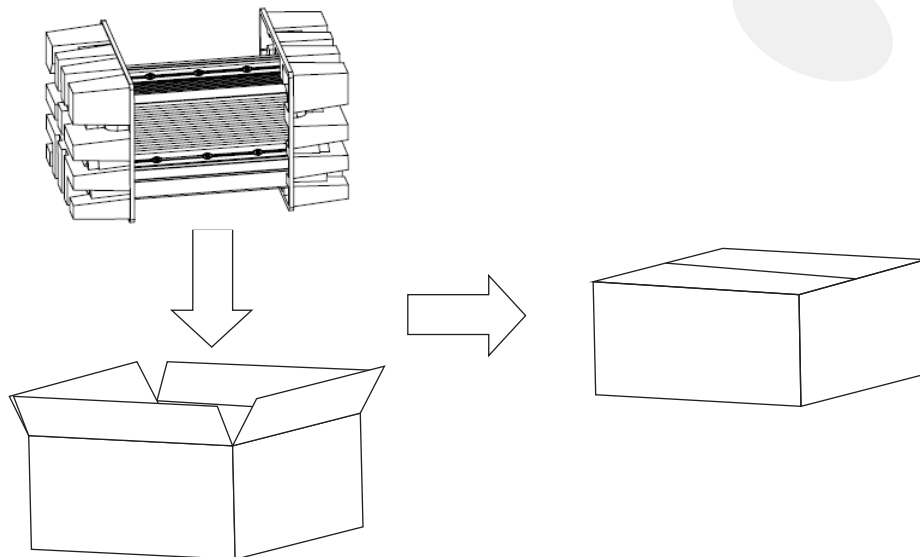



Application Image



LED WALL PACK

Warranty

5 Year Warranty